

2025 Edition



Professional Connectivity Manufacturer
Push-Pull Connectors

www.finecables.com



Push-Pull Connector
Designed for
Quick and Stable Installation



Index

	Page		Page
1. About Finecables	004	11.4 Collet Type	110
2. Push-Pull Connector Brief Introduction	006	12. E Series (Indoor)	111-124
3. Finecables Push-Pull Connector Technical Features At A Glance	006	12.1 Part Numbering System	112
4. Push-Pull Connector Applications	007	12.2 Models	113-121
5. 3 Steps To Select The Right Connector	009	12.3 Electrical & Mechanical Data	122
6. Contact	014	12.4 Insert Configuration	122
7. B Series (Indoor, Keyed)	016-048	12.5 Contact Type	123
7.1 Part Numbering System	018	12.6 Collet Type	124
7.2 Models	019-040	13. L Series (Indoor)	125-134
7.3 Electrical & Mechanical Data	041-045	13.1 Part Numbering System	126
7.4 Insert Configuration	041-045	13.2 Models	127-131
7.5 Alignment Key, Metal Material & Plate	046	13.3 Electrical & Mechanical Data	132
7.6 Insulator & Contact Type	047	13.4 Insert Configuration	132
7.7 Collet Type	048	13.5 Contact Type	133
8. K Series (Outdoor, Keyed)	049-074	13.6 Collet Type	134
8.1 Part Numbering System	051	14. Q Series (Outdoor)	135-139
8.2 Models	052-066	14.1 Part Numbering System	136
8.3 Electrical & Mechanical Data	067-071	14.2 Models	137-138
8.4 Insert Configuration	067-071	14.3 Electrical & Mechanical Data	139
8.5 Alignment Key, Metal Material & Plate	072	14.4 Insert Configuration	139
8.6 Insulator & Contact Type	073	15. R Series (outdoor)	140-150
8.7 Collet Type	074	15.1 Part Numbering System	141
9. T Series (Outdoor, Keyed)	075-085	15.2 Models	142-148
9.1 Part Numbering System	076	15.3 Electrical & Mechanical Data	149
9.2 Models	077-078	15.4 Insert Configuration	149
9.3 Electrical & Mechanical Data	079-082	15.5 Metal Material & Plate	150
9.4 Insert Configuration	079-082	15.6 Insulator & Contact Type	150
9.5 Alignment Key, Metal Material & Plate	083	15.7 Collet Type	150
9.6 Insulator & Contact Type	084	16. P Series (Indoor)	151-167
9.7 Collet Type	085	16.1 Part Numbering System	152
10. S Series (Indoor)	086-100	16.2 Models	153-164
10.1 Part Numbering System	087	16.3 Electrical & Mechanical Data	165-166
10.2 Models	088-097	16.4 Insert Configuration	165-166
10.3 Electrical & Mechanical Data	098-099	16.5 Alignment Key and Contact Type	167
10.4 Insert Configuration	098	17. Cable Assembly	168-177
10.5 Contact Type	099	18. Accessories	178-179
10.6 Collet Type	100	18.1 Bend Relief Functional Description	178
11. 00 Coaxial Series (Indoor)	101-110	18.2 SR. Bend Relief	179
11.1 Part Numbering System	102	19. Panel Cut-outs, Mounting Nut Torque	180
11.2 Models	103-109	20. PCB Drilling Pattern	181-187
11.3 Electrical & Mechanical Data	103-109		



ABOUT FINECABLES

Finecables, established in 2003, is committed to being the world's leading manufacturer in industrial connectivity. At Finecables, we combine a strong customer focus along with a wealth of practical industry experience in order to provide our clients all around the world with reliable and innovative connectivity products as well as excellent customer service. Additionally, we continue to extend our

self-owned brand @ Finecables® in various applications by developing customized products, which cover not only Push Pull connectors & industrial connectors, but also electronic interconnection and data networking. Our yearly production capacity is already more than 50 million PCS.

Push-Pull Connector Designed for Quick and Stable Installation





CORPORATE CULTURE

Finecables' corporate culture consists of passion, dedication and commitment. We are greatly enthusiastic about what we do and helping our customers realize their dreams and missions. We are committed to industrial connectivity and place great emphasis on building long-term partnerships and mutually beneficial relationships with both customers and suppliers. Very simply, we are your ideal business partner!

R & D

With years of experience and technological acquisition and accumulation in industrial connectivity, the R&D team at Finecables utilizes powerful tooling ability and productivity to continue to raise the bar for industry standards. Our unique competitive advantage allows us to research and develop innovative total solutions and fully realize our customer's specific requirements. So far, Finecables has developed over 20,000 kinds of connectors totally.

QUALITY

Quality to finecables is what health is to human beings; the core competence of products shall base on its superior performance and reliable quality. Our commitments on "high quality" come from our team's comprehensive understanding in quality. We have designed strict verification and quality control process to assure ourselves and our suppliers are offering the best product service. ISO9001, ISO14001, ISO45001, ISO13485, ESD20.20 and NMEA, CE, UKCA, UL certificates represent our quality value.

Finecables fulfills the core value of "Promptness, Excellence, Awareness, and Gratitude", by insisting on our long-term partnership and win-win cooperation with both customers and suppliers.

QUALIFICATION CERTIFICATE



Push-Pull Connector Introduction

The push-pull connectors integrate the push lock mechanism together with audible and tactile feedback, Finecables's Push-pull series connectors is the ideal mating solution for fast and easy operation in medical and industrial applications. These products are particularly suitable for high reliability and high quality applications where a simple yet fast method to connect/disconnect is required, and also suitable for high endurance and ease of operation in very limited spaces.

Technical Features At A Glance

- Fast and easy to use
- Field installable and free assembled versions
- Wire gauges range from 30 AWG to 12AWG.
- Audible and tactile feedback
- Mechanically keyed: Ensures correct polarization and alignment.
- Mating/ unmating endurance: Metal > 5000, Plastic > 2000
- Contact layouts from 2 to 48 contacts, coaxial triaxial
- Straight or right angle PCB contacts.
- Space saving
- Excellent performance under harsh environmental conditions in both high temperature and high humidity.
- Robust housings
- 360° electromagnetic shielding
- Fire and smoke compliance
- Indoor IP50, Outdoor IP68
- Solder and crimping contacts available
- RoHS conformity



APPLICATION

Push-Pull Connector Designed for Quick and Stable Installation

Finecables truly understands the cost, time and quality is important to customers. Our customized solutions and one-stop services will help you reach your objective by reducing the installation time of products by 20% to 80%, field assembly labor costs for numerous application fields: Sensors & Industrial Automation Control, Telecommunications & Network, HVAC & Refrigeration, LED Lighting, Railway Transportation System, Marine & Ship Engineering, Medical Devices, Renewable Energy, Measuring & Testing and Package conveyor and so on.



Industrial
Automation & Sensors



Drone



Package Conveyor &
Logistic System



Test Measurement



Elevator



Telecommunication System



LED Display & Lighting



Audio Video & Broadcasting



Renewable Energy



Automobile



Medical Healthy



Railway Transportation System



HVAC & Refrigeration



Marine & Ships Engineering



Agricultural Machinery



Food & Beverage Industry

■ Push-Pull Self-latching Connection System

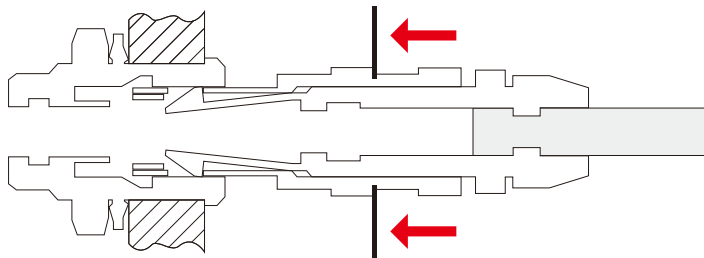
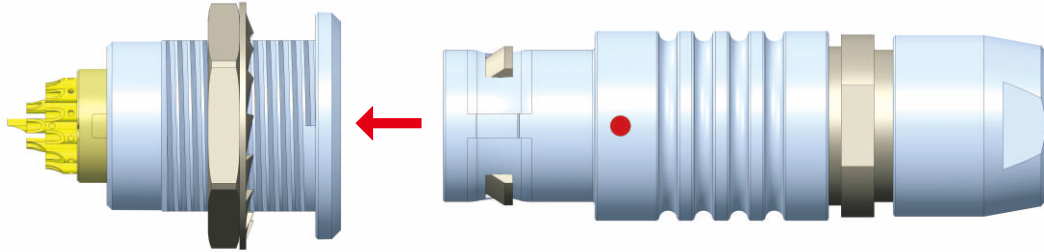

The self-latching system allows the connector to be mated by simply pushing the plug axially into the socket.

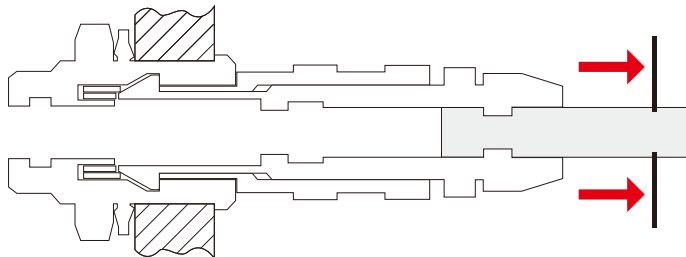

Once firmly latched, connection cannot be broken by pulling on the cable or any other component other than the outer release sleeve.

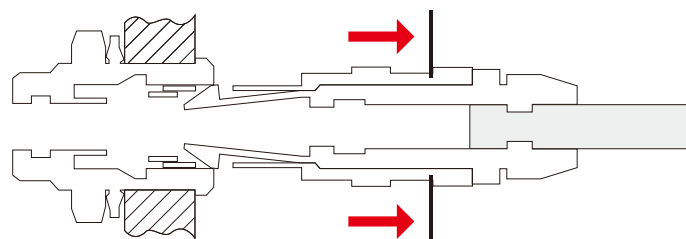

when required, the connector is disengaged by a single axial pull on the outer release sleeve. It firstly disengages the latches and then withdraws the plug from the socket.

■ Step 1 Select Connector Series

Select the appropriate Finecables connector series according to the environmental parameters that will affect your device or cable such as indoor, outdoor, temperature range, ingress protection of the mated connector and of your device.

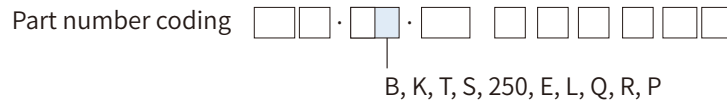

■ Step 2 Select Connector Size

Use the section (mm²) or the AWG of your cable wire to select the optimal contact diameter (values vary between solder, crimp or print contact).

Use this optimal contact diameter to determine the right connector size as well as the insert configuration.

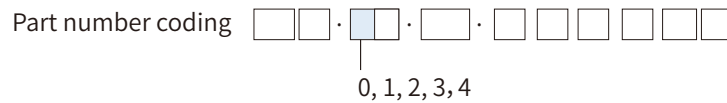

■ Step 3 Complete The Part Number

Now that you know the series, as well as the insulator configuration, complete the part numbering system with the help of the following table.

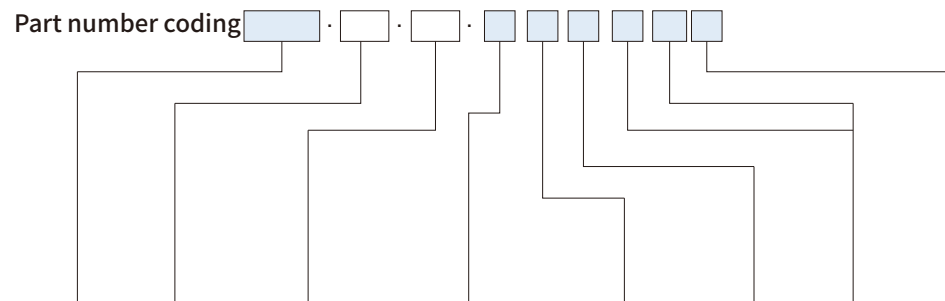

	Model	Series	Insert configuration	Housing material	Insulator material	Contact	Collet	Variant
B Series	018	019	038	046	046	047	048	179
K Series	051	052	067	072	072	073	074	179
T Series	076	077	079	083	083	084	085	179
S Series	087	088	098	099	099	099	100	179
00 Coaxial Series	102	103	102	102	102	102	102	179
E Series	112	113	122	112	112	123	124	179
L Series	126	127	132	126	126	133	134	179
Q Series	136	137	139	136	136	136	136	179
R Series	141	142	149	150	150	150	150	179
P Series	152	153	165	152	152	152	152	179

Note: Figures in the above table refer to the catalogue pages.

Step 1: Select Connector Series

The metal housing standard keyed Series (B)

The characteristic feature of B series connector is a keying system which allows higher contact density and prevents all errors in alignment. The various keying alternatives prevent unwanted cross mating of otherwise similar connectors. These connector series include the 00 to 4B & coaxial+low voltage range.

The metal housing waterproof keyed Series (K)

K series are waterproof when mated and assembled to an appropriate cable. They include the 0K to 4K series, available in the same types as the 00 to 4B series.

The metal housing waterproof keyed Series (T)

The characteristic feature of these connector series is the PTFE insulator in the coaxial triaxial version. They include principally the TT to 0T-3T series, available in the same types as the to B series.

The metal housing standard Series (S)

The characteristic feature of these connector series is the PTFE insulator in the coaxial triaxial version. They include principally the 0S to 2S coaxial triaxial & multipole & high voltage series.

The metal housing standard Series (00 Coaxial)

The characteristic feature of these connector series is the PTFE insulator in the coaxial triaxial version, available in the same types as the multipole S coaxial triaxial series.

The metal housing waterproof Series (E)

These series are waterproof when mated and assembled to an appropriate cable. They include the 0E to 2E series, available in the same types as the multipole S series.

The metal housing waterproof keyed Series (L)

This series slightly combines the androgynous glue core of S and E series with the positioning of K series, and these series are waterproof when mated and assembled to an appropriate cable. They include the 0L to 2L series, available in the same types as the multipole S to E series.

The metal housing waterproof keyed Series (Q)

Q series are waterproof when mated and assembled to an appropriate cable. Quick locking is adopted and Q series connector is Keying systems (Split Insert Carrier).

The metal housing waterproof keyed Series®

The characteristic feature of R series connector is a keying system which allows higher contact density and prevents all errors in alignment. The various keying alternatives prevent unwanted cross mating of otherwise similar connectors. These connector series include the 00 to 0R, available in the same types as the multipole B series.

The plastic housing Series (P)

The material of these series is plastic, including standard version and waterproof version when mated. They include the 1P to 2P series.



Series	B	K	T	S	00 Coaxial	E	L	Q	R	P
Environment	indoor	outdoor or harsh env.	outdoor	indoor	indoor	outdoor	outdoor	outdoor	outdoor	indoor or outdoor
Ingress protection when mated	IP50	IP68	IP66/IP68	IP50	IP50	IP66/IP68	IP66/IP68	IP68	IP67	IP50 / IP64
Temperature range	- 55~250°C	- 55~200°C	- 55~200°C	- 50~250°C	- 50~260°C	- 55~200°C	- 55~200°C	- 55~200°C	- 20~80°C	- 50~150°C
Latching	Push-Pull self-latching	Push-Pull self-latching	Push-Pull self-latching	Push-Pull self-latching	Push-Pull self-latching	Push-Pull self-latching	Push-Pull self-latching	quick locking	Push-Pull self-latching	Push-Pull self-latching
Insulator type	Multipole	Multipole	Multipole	Multipole High Voltage Coaxial triaxial	Multipole	Multipole	Multipole	Multipole	Multipole	Multipole
Contact type	Solder crimp or print	Solder crimp or print	Solder, crimp	Solder	Solder	Solder	Solder	Solder	Solder	Solder crimp or print
Pages	016~048	049~074	075~085	086~100	101~110	111~124	125~134	135~139	140~150	151~167

■ Definition of Ingress Protection (IP code)

IEC 60529 outlines an international classification system for the sealing effectiveness of enclosures of electrical equipment against the intrusion into the equipment of foreign bodies (i.e. tools, dust, fingers) and moisture. This classification system utilizes the letters IP» (Ingress Protection) followed by two digits.

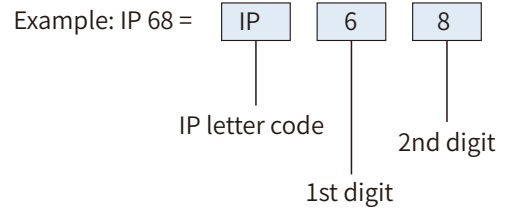

■ Degrees of protection - First digit

The first digit of the IP code indicates the degree to which persons are protected against contact with moving parts and the degree that equipment is protected against solid foreign bodies intruding into an enclosure.

Code	First digit description
0	No special protection
1	Protection from a large part of the body such as hand or from solid objects greater than 50 mm in diameter
2	Protection against objects not greater than 80 mm in length and 12 mm in diameter
3	Protection from entry by tools, wires, etc., with a diameter or thickness greater than 2.5 mm
4	Protection from entry by solid objects with a diameter or thickness greater than 1.0 mm
5	Protection from the amount of dust that would interfere with the operation of the equipment
6	Dust-tight
7	-
8	-

■ Degrees of protection - Second digit

The second digit indicates the degree of protection of the equipment inside the enclosure against the harmful entry of various forms of moisture (e.g. dripping, spraying, submersion, etc.)

Code	Second digit description
0	No special protection
1	Protection from vertically dripping water
2	Protection from dripping water when tilted up to 15°
3	Protection from sprayed water
4	Protection from splashed water
5	Protection from water projected from a nozzle
6	Protection against heavy seas, or powerful jets of water
7	Protection against temporary immersion
8	Protection against complete continuous submersion in water

■ Step 2: Select Connector Size

■ Select the right connector size and insert configuration

To be able to select the right connector size (0 to 3), it is important to define the contact diameter (ϕA).

Find out the available contact diameter (ϕA) of the connector depending on the number of contacts required and depending on the rating required.

The following table shows the contact diameter (ϕA)

Number of contacts	Insert configuration	Series										
		00/TT	0B/0K/0T	1B-1K	2B-2K	3B-3K	4B-4K	0S/0E/0L	1S/1E/1L	2S/2E/2L	1P	2P
Triaxial Coaxial												
1	650							0.9	0.9			
Multipole												
2	302	0.5	0.9	1.3	2.0	3.0		0.9	1.3	1.6	1.3	2.0
3	303	0.5	0.9	1.3	1.6	2.0		0.7	0.9	1.3		1.6
4	304	0.5	0.7	0.9	1.3	2.0	3.0	0.7	0.9	1.3	0.9	1.3
5	305	0.35	0.7	0.9	1.3	1.6			0.9 / 0.7	1.3	0.9	1.3
6	306	0.35	0.5	0.7	1.3	1.6	2.0		0.7	1.3	0.7	1.3
7	307		0.5	0.7	1.3	1.6	2.0			1.3/0.9	0.7	1.3
8	308			0.7	0.9	1.3				0.9	0.7	0.9
9	309		0.5			1.3/2.0					0.5	
10	310			0.5	0.9	1.3	1.6			0.9	0.5	0.9
12	312		0.35		0.7	0.9	1.3					0.7
14	314			0.5	0.7	0.9					0.5	
16	316			0.5	0.7	0.9	0.9					0.7
18	318				0.7	0.9						
19	319				0.7							0.7
20	320					0.7	0.9					
22	322					0.7						
24	324					0.7	0.9					
26	326				0.5	0.7						0.5
30	330					0.7	0.9					
32	332				0.5							0.5
40	340						0.7					
48	348						0.7					

■ Verify the fitting to your wire

Verify if the selected contact diameter (ϕA) of the connector fits to your cable wire diameter (AWG number or max. available section).

Contact type	Contact			Conductor						Fr 1) (N)
	ϕA (mm)	ϕC (mm)	Form per fig.	Solid		Stranded				
				AWG max.	Section max. (mm ²)	AWG		Section (mm ²)		
min.	max.	min.	max.							
Solder 	0.50	0.4	-	28	0.09	-	30	-	0.05	-
	0.50	0.5	-	28	0.09	-	28	-	0.09	-
	0.70	0.6	-	24	0.25	-	26	-	0.14	-
	0.7	0.8	-	22	0.34	-	22	-	0.34	-
	0.9	0.8	-	22	0.34	-	22	-	0.34	-
	1.3	1.0	-	20	0.50	-	20	-	0.50	-
	1.6	1.4	-	16	1.00	-	18	-	1.00	-
	2.0	1.8	-	14	1.50	-	16	-	1.50	-
	3.0	2.7	-	10	4.00	-	12	-	4.00	-
Crimp fig. 1 fig. 2 	0.5	0.45	1	-	-	32	28	0.035	0.09	12
	0.7	0.80	1	-	-	26	22	0.140	0.34	22
	0.7	0.45	2	-	-	32	28	0.035	0.09	22
	0.9	1.10	1	-	-	24	20	0.250	0.50	30
	0.9	0.80	2	-	-	26	22	0.140	0.34	30
	0.9	0.45	2	-	-	32	28	0.035	0.09	30
	1.3	1.40	1	-	-	20	18	0.500	1.00	40
	1.3	1.10	2	-	-	24	20	0.250	0.50	40
	1.3	0.80	2	-	-	26	22	0.140	0.34	40
	1.6	1.90	1	-	-	18	14	1.000	1.50	50
	1.6	1.40	2	-	-	22	18	0.340	1.00	50
	2.0	2.40	1	-	-	16	12	1.500	2.50	65
	2.0	1.90	2	-	-	18	14	1.000	1.50	65
	3.0	3.20	1	-	-	14	10	2.500	4.00	75
	Print	<p>L dimensions and C are detailed in the section on PCB drilling pattern.</p>								
Print (elbow)	<p>L dimensions and C are detailed in the section on PCB drilling pattern.</p>									

■ P1 Contact Series, Male Fluid Contact With Valve

- Connector series: P1
- Contact: Male
- Part No.:PSG.P1.150.ACV
- Mated with: FSG.P1.150.ACV

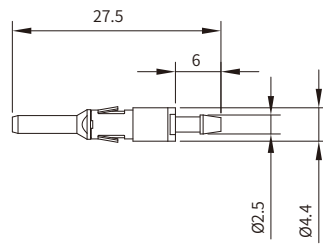

■ General Information

Ambient temperature:	-20 °C ~ + 125 °C
Endurance:	> 1000 cycles
Housing:	Stainless steel
Valve:	Stainless steel
Clips:	Brass with Ni plated

O-ring:	FPM
working pressure:	6bars max.
Air flow rate at 6 bars:	50l/min
Water flow rate at 6 bars:	0.80l/min
Salt spray corrosion test:	>144h

■ P1 Contact, Female Fluid Contact With Valve

- Connector series: P1
- Contact: Female
- Part No.:FSG.P1.150.ACV
- Mated with: PSG.P1.150.ACV

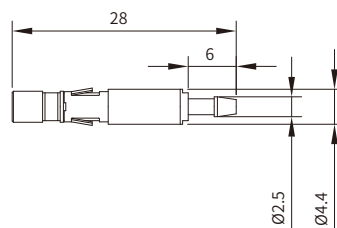

■ General Information

Ambient temperature:	-20 °C ~ + 125 °C
Endurance:	> 1000 cycles
Housing:	Stainless steel
Valve:	Stainless steel
Clips:	Brass with Ni plated

O-ring:	FPM
working pressure:	6bars max.
Air flow rate at 6 bars:	50l/min
Water flow rate at 6 bars:	0.80l/min
Salt spray corrosion test:	>144h

■ Verify the fitting to your cable

Verify if the selected connector size fits to your cable diameter.

■ B Series

Series	Cable diameter range (mm)			
	Collet		Collet for fitting a bend relief	
	min.	max.	min.	max.
00	1.1	3.4	1.1	3.4
0B	1.5	5.5	1.5	5.0
1B	2.2	7.5	2.2	7.0
2B	1.5	9.7	1.5	9.0
3B	4.1	11.7	4.1	11.0
4B	5.1	16.0	5.1	16.0

■ K Series

Series	Cable diameter range (mm)			
	Collet		Collet for fitting a bend relief	
	min.	max.	min.	max.
0K	1.0	5.0	1.0	5.0
1K	1.3	8.5	1.3	8.5
2K	1.3	10.5	1.3	10.5
3K	2.6	15.0	2.6	15.0
4K	4.6	23.5	4.6	23.5

■ T Series

Series	Cable diameter range (mm)			
	Collet		Collet for fitting a bend relief	
	min.	max.	min.	max.
TT	2.4	3.0	2.4	3.0
0T	1.3	5.0	1.3	5.0
1T	1.5	8.5	1.5	8.5
2T	1.5	10.5	1.5	10.5
3T	2.6	10.5	2.6	10.5

■ S Series

Series	Cable diameter range (mm)			
	Collet		Collet for fitting a bend relief	
	min.	max.	min.	max.
0S	1.3	6.7	1.3	6.1
1S	1.3	8.5	1.3	8.0
2S	1.3	10.5	1.3	10.0

■ 00 Coaxial Series

Series	Cable diameter range (mm)			
	Collet		Collet for fitting a bend relief	
	min.	max.	min.	max.
250	1.1	3.4	1.1	3.0

■ E/L Series

Series	Cable diameter range (mm)			
	Collet		Collet for fitting a bend relief	
	min.	max.	min.	max.
0E/0L	1.0	3.0	1.0	3.0
1E/1L	1.3	5.0	1.3	5.0
2E/2L	2.0	8.5	2.0	8.5

■ Q Series

Series	Cable diameter range (mm)	
	min.	max.
Q	1.3	5.5

■ R Series

Series	Cable diameter range (mm)			
	Collet		Collet for fitting a bend relief	
	min.	max.	min.	max.
0R	1.3	5.0	1.3	5.0
RR	2.4	3.0	2.4	3.0

■ P Series

Series	Cable diameter range (mm)			
	Collet		Collet for fitting a bend relief	
	min.	max.	min.	max.
1P	1.7	6.5	1.7	6.5
2P	3.2	9.2	3.2	9.0



B Series

Key Features:

- security of the Push-Pull self-latching system
- solder, crimp or print contacts (straight or angled)
- 360° screening for full EMC shielding.
- keying system ("G" key standard) for connector alignment
- multiple key options to avoid cross mating of similar connectors
- multipole types 2 to 32 contacts
- high packing density for space savings



■ Part Section Showing Internal Components

Fixed Socket

Straight Plug

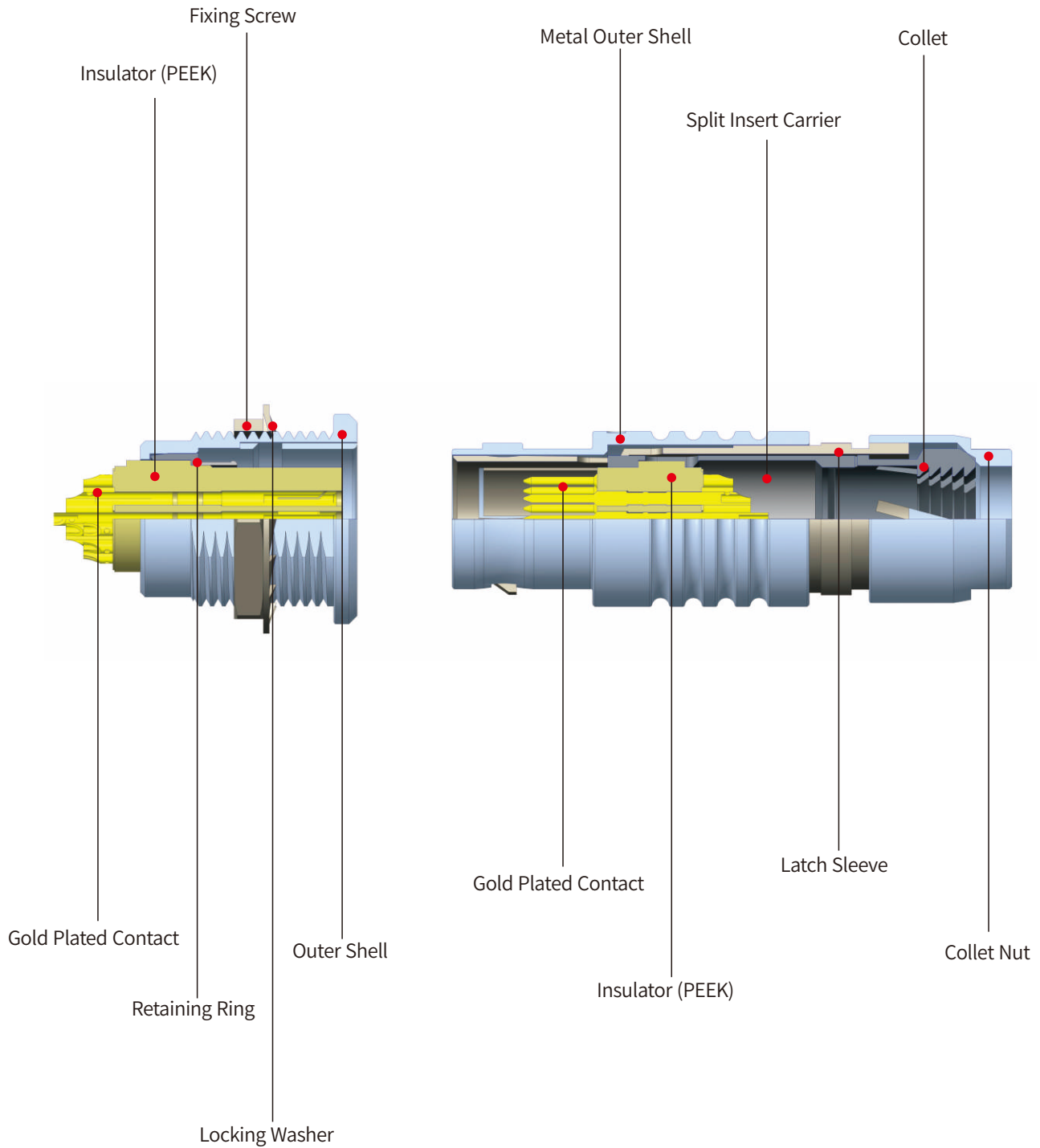

■ Part Number Definition

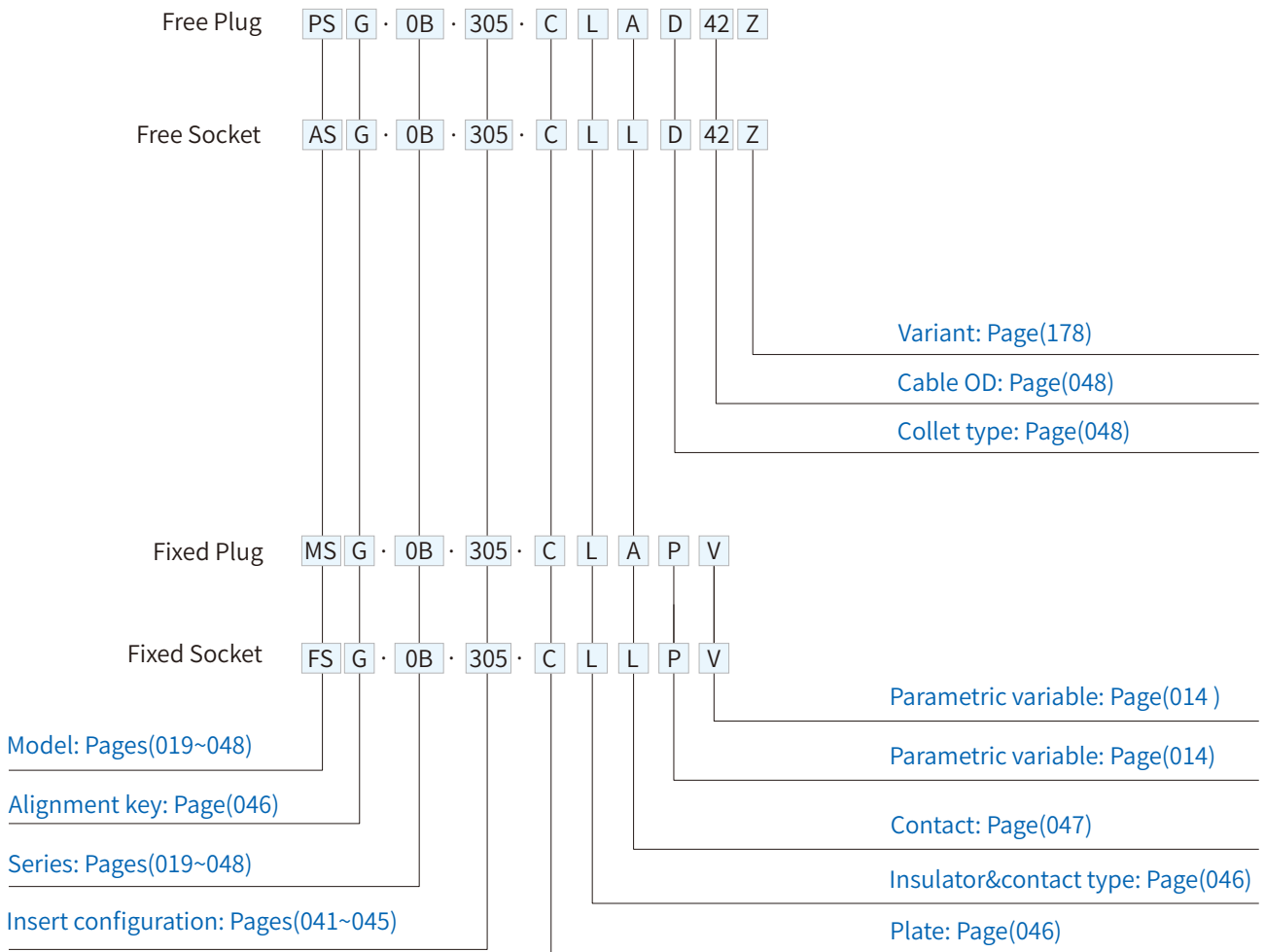

■ Part Number Example

Straight plug with cable collet:

PSG.0B.305.CLAD42=straight plug with key(G) and cable collet, 0B Series, multipole type with 5 contacts, chrome-plated brass outershell, PEEK insulator with male solder contacts, D type collet for 4.0mm diameter cable.

Straight plug with cable collet:

ASG.0B.305.CLLD42Z=free socket with key(G)and cable collet, 0B series, multipole type with 5 contacts, outershell in chrome-plated brass, PEEK insulator, female solder contacts, D type collet for 4.0mm diameter cable and nut for fitting a bend relief.

Fixed socket:

FSG.0B.305.CYM=fixed socket, nut fixing, with key(G),0B series, multipole type with 5 contacts, outershell Ichrome-plated brass, PEEK insulator, female crimp contacts.

■ PSG Straight Plug, Nut For Bend Relief, Key(G), Cable Collet

- Connector series: PSG
- Contact: Male
- Key: G(More keys, refer to page 046)
- Locking type: Self-locking
- Orientation type: Straight
- Part No.: PSG.XB.XXX.CLADXXZ
- Mated with:
FSG/SFG/SRG/SEG/FBG/PRG/ASG series
Note: "X" refers to part number definition on page 018

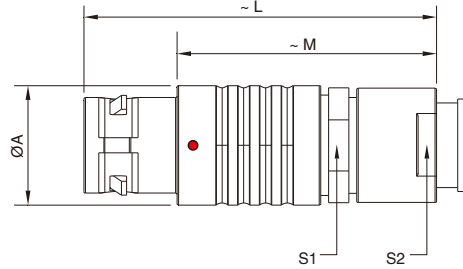

■ General Information



Ambient temperature:	-55°C~+250°C
Mating endurance:	>5000 cycles
Insulator:	PEEK
Connector contacts:	Brass with gold plated
Housing:	Brass with Cr plated

Insulation resistance:	≥ 100MΩ
IP rating:	IP 50
Shielding efficiency:	at 10MHz>75dB / at 1GHz>40dB
Salt spray corrosion test:	>144h

Size	Dimensions(mm)				
	A	L	M	S1	S2
00	6.4	36.5	28.5	5.5	5
0B	9.5	35	25	8	7
1B	12	42	31	10	9
2B	15	49	37	13	12
3B	18	56.5	41.5	15	15
4B	25	71	54	21	20

■ PSG Straight Plug, Key(G), Cable Collet

- Connector series: PSG
- Contact: Male
- Key: G(More keys, refer to page 046)
- Locking type: Self-locking
- Orientation type: Straight
- Part No.: PSG.XB.XXX.CLADXX
- Mated with:
FSG/SFG/SRG/SEG/FBG/PRG/ASG series
Note: "X" refers to part number definition on page 018

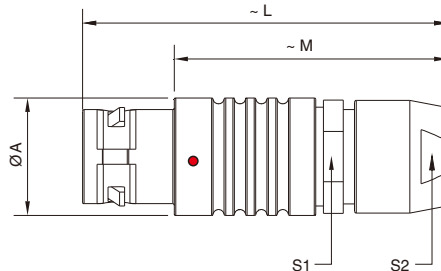

■ General Information



Ambient temperature:	-55°C~+250°C
Mating endurance:	>5000 cycles
Insulator:	PEEK
Connector contacts:	Brass with gold plated
Housing:	Brass with Cr plated

Insulation resistance:	≥ 100MΩ
IP rating:	IP 50
Shielding efficiency:	at 10MHz>75dB / at 1GHz>40dB
Salt spray corrosion test:	>144h

Size	Dimensions(mm)				
	A	L	M	S1	S2
00	6.4	28.5	20.5	5.5	5
0B	9.5	36	26	8	7
1B	12	43	32	10	9
2B	15	50	38	13	12
3B	18	58	43	15	14
4B	25	77	59	21	20

■ PLG Straight Plug, Nut for Bend Relief, Key(G), Non-latching, Cable Collet

- Connector series: PLG
- Contact: Male
- Key: G(More keys, refer to page 046)
- Locking type: Non-latching
- Orientation type: Straight
- Part No.: PLG.XB.XXX.CLADXXZ
- Mated with:
FSG/SFG/SRG/SEG/FBG/PRG/ASG series
Note: "X" refers to part number definition on page 018

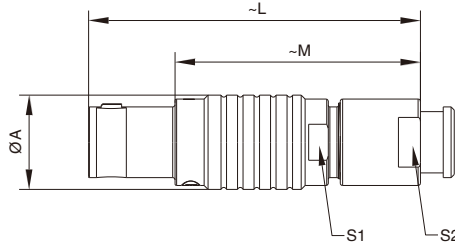

■ General Information



Ambient temperature:	-55°C~+250°C
Mating endurance:	>5000 cycles
Insulator:	PEEK
Connector contacts:	Brass with gold plated
Housing:	Brass with Cr plated

Insulation resistance:	≥ 100MΩ
IP rating:	IP 50
Shielding efficiency:	at 10MHz>75dB / at 1GHz>40dB
Salt spray corrosion test:	>144h

Size	Dimensions(mm)				
	A	L	M	S1	S2
0B	9.5	35	25	8	7
1B	12.0	42	31	10	9
2B	15.0	49	37	13	12
3B	18.0	56.5	41.5	15	14

■ PLG Straight Plug, Key(G), Non-latching, Cable Collet

- Connector series: PLG
- Contact: Male
- Key: G(More keys, refer to page 046)
- Locking type: Non-latching
- Orientation type: Straight
- Part No.: PLG.XB.XXX.CLADXXX
- Mated with:
FSG/SFG/SRG/SEG/FBG/PRG/ASG series
Note: "X" refers to part number definition on page 018

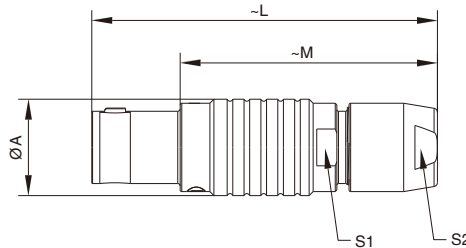

■ General Information



Ambient temperature:	-55°C~+250°C
Mating endurance:	>5000 cycles
Insulator:	PEEK
Connector contacts:	Brass with gold plated
Housing:	Brass with Cr plated

Insulation resistance:	≥ 100MΩ
IP rating:	IP 50
Shielding efficiency:	at 10MHz>75dB / at 1GHz>40dB
Salt spray corrosion test:	>144h

Size	Dimensions(mm)				
	A	L	M	S1	S2
0B	9.5	36	26	8	7
1B	12.0	43	32	10	9
2B	15.0	50	38	13	12
3B	18.0	58	43	15	14

■ PFG Straight Plug, Key(G), Lanyard Release, Cable Collet

- Connector series: PFG
 - Contact: Male
 - Key: G(More keys, refer to page 046)
 - Locking type: Self-locking
 - Orientation type: Straight (lanyard release)
 - Part No.: PFG.XB.XXX.CLADXX
 - Mated with: FSG/SFG/SRG/SEG/FBG/PRG/ASG
- Note: "X" refers to part number definition on page 018

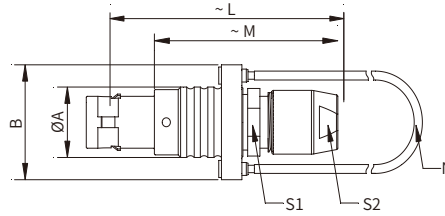

■ General Information



Ambient temperature:	-55°C~+250°C
Endurance:	>5000 cycles
Insulator:	PEEK
Connector contacts:	Brass with gold plated
Housing:	Brass with Cr plated

Insulation resistance:	≥100MΩ
IP rating:	IP 50
Shielding efficiency:	at 10MHz>75dB/at 1GHz>40dB
Salt spray corrosion test:	>144h

Size	Dimensions(mm)						
	A	B	L	M	N	S1	S2
0B	9.5	15.5	36.0	26.0	140	8.0	7.0
1B	12.0	18.0	43.0	32.0	140	10.0	9.0
2B	15.0	21.0	49.0	37.0	160	13.0	12.0
3B	18.0	25.0	58.0	43.0	190	15.0	14.0

■ PAG Angled Plug, Key(G), Cable Collet

- Connector series: PAG
 - Contact: Male
 - Key: G(More keys, refer to page 046)
 - Locking type: Self-locking
 - Orientation type: Elbow (90°)
 - Part No.: PAG.XB.XXX.CLADXX
 - Mated with: FSG/SFG/SRG/SEG/FBG/PRG/ASG series
- Note: "X" refers to part number definition on page 018

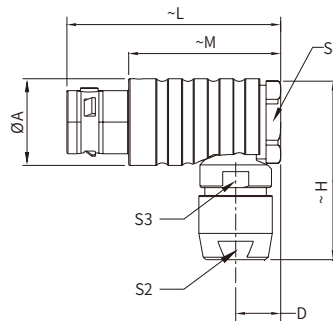

■ General Information



Ambient temperature:	-55°C~+250°C
Mating endurance:	>5000 cycles
Insulator:	PEEK
Connector contacts:	Brass with gold plated
Housing:	Brass with Cr plated

Insulation resistance:	≥ 100MΩ
IP rating:	IP 50
Shielding efficiency:	at 10MHz>75dB / at 1GHz>40dB
Salt spray corrosion test:	>144h

Size	Dimensions(mm)							
	A	D	H	L	M	S1	S2	S3
00	7.7	5.2	18.0	24.5	16.5	7	5	5.5
0B	11.0	6.5	26.0	31.6	21.6	10	7	8.0
1B	13.5	8.0	30.5	36.0	25.0	11	9	10.0
2B	16.5	9.0	34.0	41.5	29.5	14	12	13.0
3B	19.0	10.0	37.0	50.0	35.0	17	14	15.0
4B	26.0	15.0	53.0	67.0	49.0	22.0	20.0	21

PAG Angled Plug, Nut for Bend Relief, Key(G), Cable Collet

- Connector series: PAG
- Contact: Male
- Key: G(More keys, refer to page 046)
- Locking type: Self-locking
- Orientation type: Elbow (90°)
- Part No.: PAG.XB.XXX.CLADXXZ
- mated with:
FSG/SFG/SRG/SEG/FBG/PRG/ASG series
Note: "X" refers to part number definition on page 018

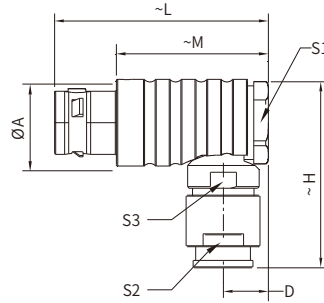

General Information



Ambient temperature:	-55°C~+250°C
Mating endurance:	>5000 cycles
Insulator:	PEEK
Connector contacts:	Brass with gold plated
Housing:	Brass with Cr plated

Insulation resistance:	≥ 100MΩ
IP rating:	IP 50
Shielding efficiency:	at 10MHz>75dB / at 1GHz>40dB
Salt spray corrosion test:	>144h

Size	Dimensions(mm)							
	A	D	H	L	M	S1	S2	S3
00	7.7	5.2	19.5	24.5	16.5	7	5	5.5
0B	11.0	6.5	28.0	31.6	21.6	10	7	8.0
1B	13.5	8.0	33.5	36.0	25.0	11	9	10.0
2B	16.5	9.0	38.5	41.5	29.5	14	12	13.0
3B	19.0	10.0	42.0	50.0	35.0	17	14	15.0
4B	26.0	15.0	57.5	67.0	49.0	22.0	20.0	21

PCG New Angled(90°) Plug, Key(G), Cable Collet

- Connector series: PCG
- Contact: Male
- Key: G(More keys, refer to page 046)
- Locking type: Self-locking
- Orientation type: Elbow (90°)
- Part No.: PCG.XB.XXX.CLADXX
- Mated with: FSG/SFG/SRG/SEG/FBG/PRG/ASG
Note: "X" refers to part number definition on page 018

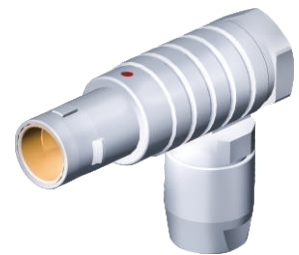
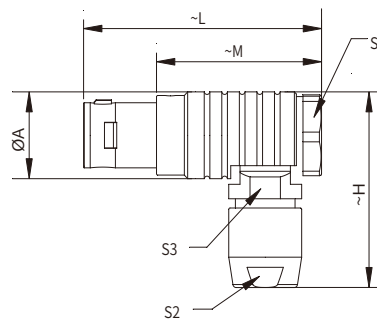

General Information



Ambient temperature:	-55°C~+250°C
Endurance:	>5000 cycles
Insulator:	PEEK
Connector contacts:	Brass with gold plated
Housing:	Brass with Cr plated

Insulation resistance:	≥ 100MΩ
IP rating:	IP 50
Shielding efficiency:	at 10MHz>75dB/at 1GHz>40dB
Salt spray corrosion test:	>144h

Size	Dimensions(mm)							
	A	H	L	M	S1	S2	S3	
00	7.5	18.0	24.5	16.5	7.0	5.0	5.3	
0B	9.5	23.0	30.0	20.0	9.0	7.0	8.0	
1B	12.0	29.0	36.0	25.0	11.0	9.0	10.0	
2B	15.0	35.0	41.5	29.5	14.0	12.0	13.0	

■ PBG Adjustable Angled Plug, Key(G), Cable Collet

- Connector series: PBG
 - Contact: Male
 - Key: G(More keys, refer to page 046)
 - Locking type: Self-locking
 - Orientation type: Adjustable angle
 - Part No.: PBG.XB.XXX.CLADXX
 - Mated with: FSG/SFG/SRG/SEG/FBG/PRG/ASG
- Note: "X" refers to part number definition on page 018

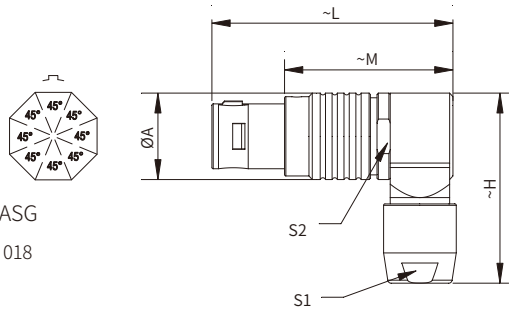

■ General Information

Ambient temperature:	-55°C~+250°C
Endurance:	>5000 cycles
Insulator:	PEEK
Connector contacts:	Brass with gold plated
Housing:	Brass with Cr plated

Insulation resistance:	≥100MΩ
IP rating:	IP 50
Shielding efficiency:	at 10MHz>75dB/at 1GHz>40dB
Salt spray corrosion test:	>144h

Size	Dimensions(mm)					
	A	H	L	M	S1	S2
00	8.0	18.1	24.8	16.8	5.0	7.0
0B	10.0	22.4	30.3	20.3	7.0	9.0
1B	12.0	26.4	36.5	25.5	9.0	11.0
2B	16.5	34.5	44.0	32.0	12.0	15.0

■ PVG Rotatable Angled Plug, Key(G), Cable Collet

- Connector series: PVG
 - Contact: Male
 - Key: G(More keys, refer to page 046)
 - Locking type: Self-locking
 - Orientation type: Adjustable angle
 - Part No.: PVG.XB.XXX.CLADXX
 - Mated with: FSG/SFG/SRG/SEG/FBG/PRG/ASG
- Note: "X" refers to part number definition on page 018

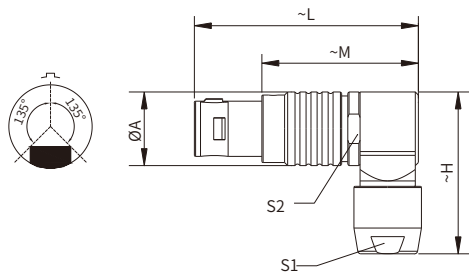

■ General Information

Ambient temperature:	-55°C ~ + 250°C
Endurance:	>5000 cycles
Insulator:	PEEK
Connector contacts:	Brass with gold plated
Housing:	Brass with Cr plated

Insulation resistance:	≥100MΩ
IP rating:	IP 50
Shielding efficiency:	at 10MHz>75dB/at 1GHz>40dB
Salt spray corrosion test:	>144h

Size	Dimensions(mm)					
	A	H	L	M	S1	S2
00	8.0	18.1	24.8	16.8	5.0	7.0
0B	10.0	22.4	30.3	20.3	7.0	9.0
1B	12.0	26.4	36.5	25.5	9.0	11.0
2B	16.5	34.5	44.0	32.0	12.0	15.0

■ MSG Fixed Straight Plug, Key(G)

- Connector series: MSG
- Contact: Male
- Key: G(More keys, refer to page 046)
- Locking type: Self-locking
- Orientation type: Straight
- Part No.: MSG.XB.XXX.CLA
- Mated with:
FSG/SFG/SRG/SEG/FBG/PRG/ASG series
Note: "X" refers to part number definition on page 018

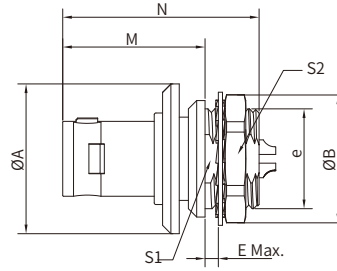

■ General Information



Ambient temperature:	-55°C~+250°C
Mating endurance:	>5000 cycles
Insulator:	PEEK
Connector contacts:	Brass with gold plated
Coupling nut/screw:	Brass with nickel plated

Housing:	Brass with Cr plated
Insulation resistance:	≥ 100MΩ
IP rating:	IP 50
Shielding efficiency:	at 10MHz>75dB / at 1GHz>40dB
Salt spray corrosion test:	>144h

Size	Dimensions(mm)							
	A	B	e	E	M	N Max	S1	S2
0B	14.0	12.4	M9*0.6	1.8	14.5	19.5	8.2	11
1B	18.0	15.8	M12*1.0	2.9	17	24.8	10.5	14
2B	19.5	19.2	M15*1.0	4.1	18	27.3	13.5	17
3B	25.0	25.0	M18*1.0	4.2	23	31.5	16.5	22

Panel Cut-out page 180; The dimension " N " depends on the number of contacts, detail information see page 185

■ PPG Fixed Straight Plug, Key(G), Non-latching

- Connector series: PPG
- Contact: Male
- Key: G(More keys, refer to page 046)
- Locking type: Non-latching
- Orientation type: Straight
- Part No.: PPG.XB.XXX.CLA
- Mated with:
FSG/SFG/SRG/SEG/FBG/PRG/ASG series
Note: "X" refers to part number definition on page 018

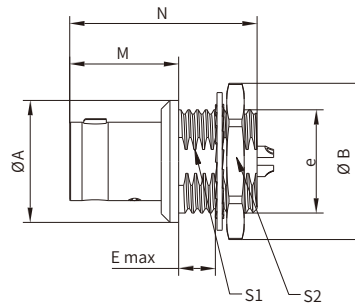

■ General Information



Ambient temperature:	-55°C~+250°C
Mating endurance:	>5000 cycles
Insulator:	PEEK
Connector contacts:	Brass with gold plated
Coupling nut/screw:	Brass with nickel plated

Housing:	Brass with Cr plated
Insulation resistance:	≥ 100MΩ
IP rating:	IP 50
Shielding efficiency:	at 10MHz>75dB / at 1GHz>40dB
Salt spray corrosion test:	>144h

Size	Dimensions(mm)							
	A	B	e	E	M	N Max	S1	S2
00	8	10.2	M7*0.5	2.9	9.0	15.9	6.3	9
0B	10	12.4	M9*0.6	4.2	11.5	18.9	8.2	11
1B	14	15.8	M12*1.0	5.4	12.5	21.6	10.5	14
2B	18	19.2	M15*1.0	6.0	13.8	23.9	13.5	17
3B	22	25.0	M18*1.0	5.8	17.0	30.2	16.5	22

Panel Cut-out page 180; The dimension " N " depends on the number of contacts, detail information see page 185

FSG Fixed Straight Socket, Key(G)

- Connector series: FSG
- Contact: Female
- Key: G(More keys, refer to page 046)
- Locking type: Self-locking
- Orientation type: Straight
- Part No.: FSG.XB.XXX.CLL
- Mated with: PSG/MSG/PLG/PPG series

Note: "X" refers to part number definition on page 018

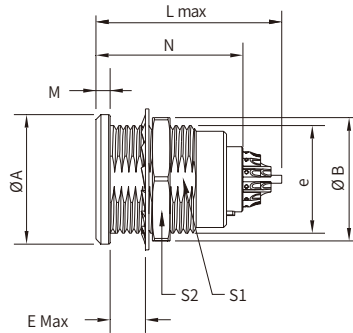

General Information



Ambient temperature:	-55°C~+250°C
Mating endurance:	>5000 cycles
Insulator:	PEEK
Connector contacts:	Brass with gold plated
Coupling nut/screw:	Brass with nickel plated

Housing:	Brass with Cr plated
Insulation resistance:	≥ 100MΩ
IP rating:	IP 50
Shielding efficiency:	at 10MHz>75dB / at 1GHz>40dB
Salt spray corrosion test:	>144h

Size	Dimensions(mm)								
	A	B	e	E	L	M	N Max	S1	S2
00	8	10.2	M7*0.5	6.0	15.5	1.0	13.7	6.3	9
0B	10	12.4	M9*0.6	7.0	20.7	1.2	19.1	8.2	11
1B	14	15.8	M12*1.0	7.5	23.0	1.5	21.1	10.5	14
2B	18	19.2	M15*1.0	8.5	26.7	1.8	24.6	13.5	17
3B	22	25.0	M18*1.0	11.5	30.7	2.0	28.1	16.5	22
4B	28	30.0	M25*1.0	14.0	34.5	2.5	29.5	23.5	30

Panel Cut-out page 180; The dimension "N" depends on the number of contacts, detail information see page 185

FSG Fixed Straight Socket, Key(G), Contact for Printed Circuit

- Connector series: FSG
- Contact: Female
- Key: G(More keys, refer to page 046)
- Locking type: Self-locking
- Orientation type: Straight
- Part No.: FSG.XB.XXX.CLN
- Mated with: PSG/PAG/PCG/PBG/MSG/PLG/PPG

Note: "X" refers to part number definition on page 018

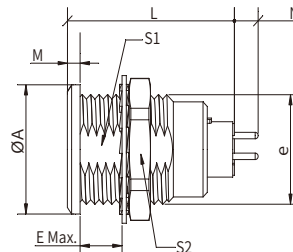

General Information



Ambient temperature:	-55°C~+250°C
Endurance:	>5000 cycles
Insulator:	PEEK
Connector contacts:	Brass with gold plated
Coupling nut/screw:	Brass with nickel plated

Housing:	Brass with Cr plated
Insulation resistance:	≥ 100MΩ
IP rating:	IP 50
Shielding efficiency:	at 10MHz>75dB/at 1GHz>40dB
Salt spray corrosion test:	>144h

Size	Dimensions(mm)						
	A	e	E	L Max	M	S1	S2
00	8.0	M7*0.5	6.0	13.7	1.0	6.3	9.0
0B	10.0	M9*0.6	7.0	19.1	1.2	8.2	11.0
1B	14.0	M12*1.0	7.5	21.1	1.5	10.5	14.0
2B	18.0	M15*1.0	8.5	24.6	1.8	13.5	17.0
3B	22.0	M18*1.0	11.5	28.1	2.0	16.5	22.0

Panel cut-out (page 180); PCB drilling pattern (page 185/186); 00 Series UL certification is ongoing

SFG Fixed Straight Socket, Key(G), Two Nuts

- Connector series: SFG
- Contact: Female
- Key: G(More keys, refer to page 046)
- Locking type: Self-locking
- Orientation type: Straight
- Part No.: SFG.XB.XXX.CLL
- Mated with: PSG/MSG/PLG/PPG series

Note: "X" refers to part number definition on page 018

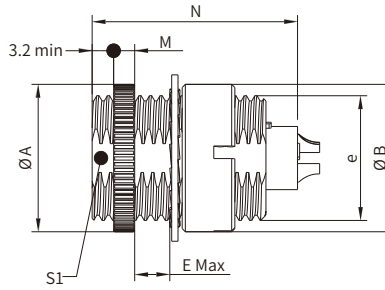

General Information



Ambient temperature:	-55°C~+250°C
Mating endurance:	>5000 cycles
Insulator:	PEEK
Connector contacts:	Brass with gold plated
Coupling nut/screw:	Brass with nickel plated

Housing:	Brass with Cr plated
Insulation resistance:	≥ 100MΩ
IP rating:	IP 50
Shielding efficiency:	at 10MHz>75dB / at 1GHz>40dB
Salt spray corrosion test:	>144h

Size	Dimensions(mm)						
	A	B	e	E	M	N Max	S1
00	9.5	9	M7*0.5	4.2	2	13.7	-
1B	14.0	14	M12*1.0	8.0	2	21.1	10.5

Panel Cut-out page 180; The dimension " N " depends on the number of contacts, detail information see page 185

SEG Fixed Straight Socket, Key(G), Earthing Tag

- Connector series: SEG
- Contact: Female
- Key: G(More keys, refer to page 046)
- Locking type: Self-locking
- Orientation type: Straight
- Part No.: SEG.XB.XXX.CLL
- Mated with: PSG/MSG/PLG/PPG series

Note: "X" refers to part number definition on page 018

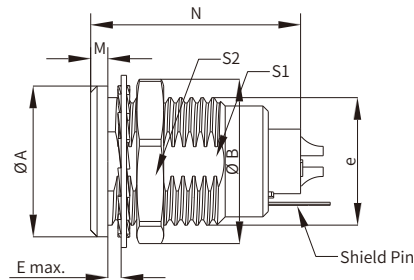

General Information



Ambient temperature:	-55°C~+250°C
Mating endurance:	>5000 cycles
Insulator:	PEEK
Connector contacts:	Brass with gold plated
Coupling nut/screw:	Brass with nickel plated

Housing:	Brass with Cr plated
Insulation resistance:	≥ 100MΩ
IP rating:	IP 50
Shielding efficiency:	at 10MHz>75dB / at 1GHz>40dB
Salt spray corrosion test:	>144h

Size	Dimensions(mm)							
	A	B	e	E	M	N Max	S1	S2
00	8	10.2	M7*0.5	6.0	1.0	13.7	6.3	9
0B	10	12.4	M9*0.6	7.0	1.2	19.1	8.2	11
1B	14	15.8	M12*1.0	7.5	1.5	21.1	10.5	14
2B	18	19.2	M15*1.0	8.5	1.8	24.6	13.5	17
3B	22	25.0	M18*1.0	11.5	2.0	28.1	16.5	22

Panel Cut-out page 180; The dimension " N " depends on the number of contacts, detail information see page 185

Note: for the 1B series the shield pin is on the same of the key

■ SWG Fixed Socket, Nut Fixing, Key(G), Watertight

- Connector series: SWG
 - Contact: Female
 - Key: G(More keys, refer to page 046)
 - Locking type: Self-locking
 - Orientation type: Straight
 - Part No.: SWG.XB.XXX.CLLPV
 - Mated with: PSG/PAG/PCG/PBG/MSG/PLG/PPG
- Note: "X" refers to part number definition on page 018

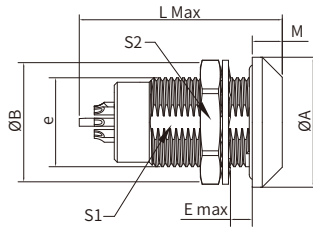

■ General Information



Ambient temperature:	-20°C ~ +80°C/100°C
Endurance:	>5000 cycles
Insulator:	PEEK
Connector contacts:	Brass with gold plated
Coupling nut/screw:	Brass with nickel plated

Housing:	Brass with Cr plated
Insulation resistance:	≥100MΩ
IP rating:	IP 50
Shielding efficiency:	at 10MHz>75dB/at 1GHz>40dB
Salt spray corrosion test:	>144h

Size	Dimensions(mm)							
	A	B	e	E	L	M	S1	S2
00	11	10.2	M7*0.5	8.0	18.0	1.5	6.3	9
0B	13	12.4	M9*0.6	7.0	24.5	4.8	8.2	11
1B	18	15.8	M12*1.0	7.0	30.3	5.2	10.5	14
2B	22	19.2	M15*1.0	8.0	35.6	6.0	13.5	17
3B	25	25	M18*1.0	11.5	41.3	7.2	16.5	22

Note: Panel cut-out (page 180)

■ FFG Fixed Straight Socket, Key(G)

- Connector series: FFG
 - Contact: Female
 - Key: G(More keys, refer to page 046)
 - Locking type: Self-locking
 - Orientation type: Straight
 - Part No.: FFG.XB.XXX.CLL
 - Mated with: PSG/PAG/PCG/PBG/MSG/PLG/PPG
- Note: "X" refers to part number definition on page 018

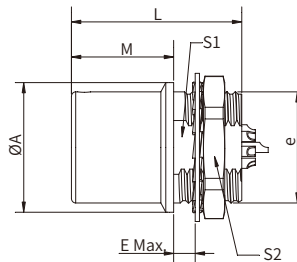

■ General Information



Ambient temperature:	-55°C~+250°C
Endurance:	>5000 cycles
Insulator:	PEEK
Connector contacts:	Brass with gold plated
Coupling nut/screw:	Brass with nickel plated

Housing:	Brass with Cr plated
Insulation resistance:	≥100MΩ
IP rating:	IP 50
Shielding efficiency:	at 10MHz>75dB/at 1GHz>40dB
Salt spray corrosion test:	>144h

Size	Dimensions(mm)							
	A	e	E	L Max	M	S1	S2	
00	8.0	M7*0.5	2.0	13.7	8.5	6.3	9.0	
0B	10.0	M9*0.6	2.0	19.1	12.5	8.2	11.0	
1B	14.0	M12*1.0	4.0	21.1	12.0	10.5	14.0	
2B	18.0	M15*1.0	5.1	24.6	12.5	13.5	17.0	
3B	22.0	M18*1.0	7.1	30.3	13.5	16.5	22.0	

Panel cut-out (page 180)

■ SRG Fixed Straight Socket, Key(G), Front Fasten

- Connector series: SRG
- Contact: Female
- Key: G(More keys, refer to page 046)
- Locking type: Self-locking
- Orientation type: Straight
- Part No.: SRG.XB.XXX.CLL
- Mated with: PSG/MSG/PLG/PPG series

Note: "X" refers to part number definition on page 018

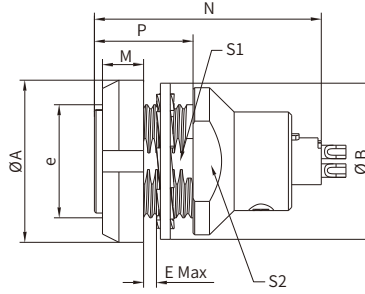

■ General Information



Ambient temperature:	-55°C~+250°C
Mating endurance:	>5000 cycles
Insulator:	PEEK
Connector contacts:	Brass with gold plated
Coupling nut/screw:	Brass with cr plated

Housing:	Brass with Cr plated
Insulation resistance:	≥ 100MΩ
IP rating:	IP 50
Shielding efficiency:	at 10MHz>75dB / at 1GHz>40dB
Salt spray corrosion test:	>144h

Size	Dimensions(mm)								
	A	B	e	E	M	N Max	P	S1	S2
00	10	9.5	M7*0.5	2.3	2.5	15.5	6.0	6.3	7.5
0B	12	12.5	M9*0.6	2.4	2.5	20.7	6.3	8.2	9.0
1B	16	16.0	M12*1.0	6.5	3.5	23.0	11.0	10.5	13.0
2B	20	20.0	M15*1.0	4.3	3.5	26.7	9.0	13.5	15.0
3B	24	25.0	M18*1.0	6.1	4.5	30.7	12.0	16.5	20.0

Panel Cut-out page 180; The dimension " N " depends on the number of contacts, detail information see page 185

■ SRG Fixed Straight Socket, Key(G), Front Fasten, Contact For Printed Circuit

- Connector series: SRG
- Contact: Female
- Key: G(More keys, refer to page 046)
- Locking type: Self-locking
- Orientation type: Straight
- Part No.: SRG.XB.XXX.CLN
- Mated with: PSG/PAG/PCG/PBG/MSG/PLG/PPG

Note: "X" refers to part number definition on page 018

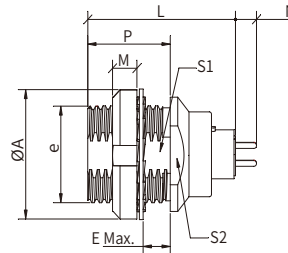

■ General Information



Ambient temperature:	-55°C~+250°C
Endurance:	>5000 cycles
Insulator:	PEEK
Connector contacts:	Brass with gold plated
Housing:	Brass with Cr plated

Insulation resistance:	≥ 100MΩ
IP rating:	IP 50
Shielding efficiency:	at 10MHz>75dB/at 1GHz>40dB
Salt spray corrosion test:	>144h

Size	Dimensions(mm)								
	A	e	E	L Max	M	P	S1	S2	
00	10.0	M7*0.5	2.3	13.7	2.5	6.0	6.3	7.5	
0B	12.0	M9*0.6	2.4	19.1	2.5	6.3	8.2	9.0	
1B	16.0	M12*1.0	6.5	21.1	3.5	11.0	10.5	13.0	
2B	20.0	M15*1.0	4.3	24.6	3.5	9.0	13.5	15.0	
3B	24.0	M18*1.0	6.1	28.1	4.5	6.0	16.5	20.0	

Panel cut-out (page 180); PCB drilling pattern (page 185/186)

■ FBG Fixed Angled Socket, Key(G), Two Nuts

- Connector series: FBG
- Contact: Female
- Key: G(More keys, refer to page 046)
- Locking type: Self-locking
- Orientation type: Angled
- Part No.: FBG.XB.XXX.CLV
- Mated with: PSG/MSG/PLG/PPG series

Note: "X" refers to part number definition on page 018

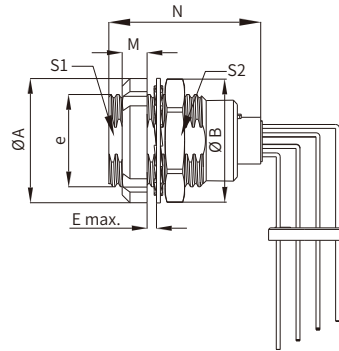

■ General Information

Ambient temperature:	-55°C~+250°C	Housing:	Brass with Cr plated
Mating endurance:	>5000 cycles	Insulation resistance:	≥ 100MΩ
Insulator:	PEEK	IP rating:	IP 50
Connector contacts:	Brass with gold plated	Shielding efficiency:	at 10MHz>75dB / at 1GHz>40dB
Coupling nut/screw:	Brass with nickel plated	Salt spray corrosion test:	>144h

Size	Dimensions(mm)							
	A	B	e	E	M	N Max	S1	S2
0B	12	12.4	M9*0.6	5.5	2.5	19.1	8.2	11
1B	16	15.8	M12*1.0	6.0	3.5	21.1	10.5	14
2B	20	19.2	M15*1.0	6.5	3.5	24.6	13.5	17
3B	24	25.0	M18*1.0	9.0	4.5	28.1	16.5	22

Panel Cut-out page 180; PCB drilling pattern page 185/186; The dimension "N" depends on the number of contacts, detail information see page 185

■ FBG Fixed Straight Socket, Key(G), Contact For Printed Circuit, Flexible Installation

- Connector series: FBG
- Contact: Female
- Key: G(More keys, refer to page 046)
- Locking type: Self-locking
- Orientation type: Straight
- Part No.: FBG.XB.XXX.CLN
- Mated with: PSG/PAG/PCG/PBG/MSG/PLG/PPG

Note: "X" refers to part number definition on page 018

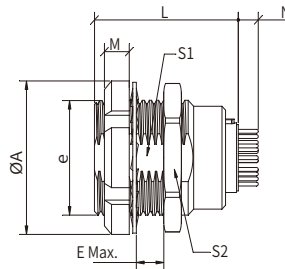

■ General Information

Ambient temperature:	-55°C~+250°C	Housing:	Brass with Cr plated
Endurance:	>5000 cycles	Insulation resistance:	≥ 100MΩ
Insulator:	PEEK	IP rating:	IP 50
Connector contacts:	Brass with gold plated	Shielding efficiency:	at 10MHz>75dB/at 1GHz>40dB
Coupling nut/screw:	Brass with Cr/nickel plated	Salt spray corrosion test:	>144h

Size	Dimensions(mm)						
	A	e	E	L Max	M	S1	S2
00	10.0	M7*0.5	4.3	13.7	2.5	6.3	9.0
0B	12.0	M9*0.6	5.5	19.1	2.5	8.2	11.0
1B	16.0	M12*1.0	6.0	21.1	3.5	10.5	14.0
2B	20.0	M15*1.0	6.5	24.6	3.5	13.5	17.0
3B	24.0	M18*1.0	9.0	28.1	4.5	16.5	22.0
4B	35.0	M25*1.0	10.0	29.5	4.5	23.5	30.0

Panel Cut-out page 180; PCB drilling pattern (page 185/186)

FHG Straight Socket, Contact For Printed Circuit, Key(G)

- Connector series: FHG
 - Contact: Female
 - Key: G(More keys, refer to page 046)
 - Locking type: Self-locking
 - Orientation type: Straight
 - Part No.: FHG.XB.XXX.CLN
 - Mated with: PSG/PAG/PCG/PBG/MSG/PLG/PPG
- Note: "X" refers to part number definition on page 018

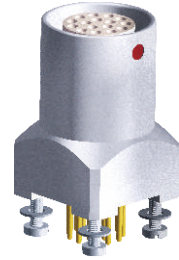
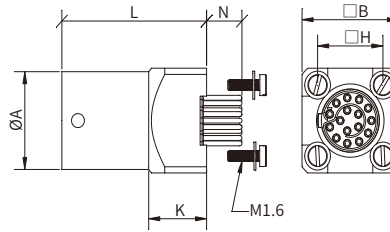

General Information



Ambient temperature:	-55°C~+250°C
Endurance:	>5000 cycles
Insulator:	PEEK
Connector contacts:	Brass with gold plated
Housing:	Brass with Cr plated

Insulation resistance:	≥ 100MΩ
IP rating:	IP 50
Shielding efficiency:	at 10MHz>75dB/at 1GHz>40dB
Salt spray corrosion test:	>144h

Size	Dimensions(mm)				
	A	B	H	K	L
0B	9.0	10.0	7.62	8.0	15.0
1B	11.0	12.0	7.62	8.0	19.0
2B	14.0	15.0	10.16	9.0	22.5

PCB drilling pattern(pages 185/186)

FXG Fixed Angled (90°) Socket, Key(G), Contact For Printed Circuit

- Connector series: FXG
 - Contact: Female
 - Coding: G(More coding, refer to page 046)
 - Locking type: Self-locking
 - Orientation type: Angled
 - Part No.: FXG.XB.XXX.HLN
 - Mated with: PSG/MSG series
- Note: "X" refers to part number definition on page 018

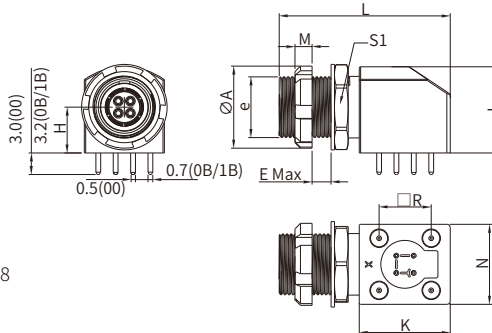

General Information



Ambient temperature:	-55°C~+250°C
Mating endurance:	>5000 cycles
Insulator:	PEEK
Connector contacts:	Brass with gold plated
Coupling nut/screw:	Brass with Cr/nickel plated

Housing:	Brass with Cr plated
Insulation resistance:	≥ 100MΩ
IP rating:	IP 50
Shielding efficiency:	at 10MHz>75dB / at 1GHz>40dB
Salt spray corrosion test:	>144h

Size	Dimensions(mm)									
	A	e	M	E	S1	I	H	R	N	K
00	10	7*0.5	2.5	2.1	9.0	7.0	3.5	5.08	7.1	8.7
0B	12	9*0.6	2.5	4.5	11.0	12.7	6.7	7.62	11.7	13.3
1B	14	11*0.5	3.5	7.5	13.0	14.0	7.5	7.62	12.6	13.3

Panel Cut-out page 180; PCB drilling pattern page 185/186; The dimension " N" depends on the number of contacts, detail information see page 185

■ ASG Free Straight Socket, Nut for Bend Relief, Key(G)

- Connector series: ASG
- Contact: Female
- Key: G(More keys, refer to page 046)
- Locking type: Self-locking
- Orientation type: Straight
- Part No.: ASG.XB.XXX.CLLDXXZ
- Mated with: PSG/MSG series

Note: "X" refers to part number definition on page 018

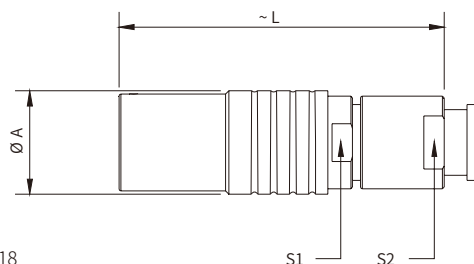

■ General Information



Ambient temperature:	-55°C~+250°C
Mating endurance:	>5000 cycles
Insulator:	PEEK
Connector contacts:	Brass with gold plated
Housing:	Brass with Cr plated

Insulation resistance:	≥ 100MΩ
IP rating:	IP 50
Shielding efficiency:	at 10MHz>75dB / at 1GHz>40dB
Salt spray corrosion test:	>144h

Size	Dimensions(mm)			
	A	L	S1	S2
00	6.8	26.0	5.5	6.0
0B	9.5	34.5	8.0	7.0
1B	12.5	39.5	10.0	9.0
2B	16.5	46.0	13.0	12.0
3B	19.0	54.5	15.0	15.0
4B	26.0	73.0	21.0	20.0

■ ASG Free Straight Socket, Key(G)

- Connector series: ASG
- Contact: Female
- Key: G(More keys, refer to page 046)
- Locking type: Self-locking
- Orientation type: Straight
- Part No.: ASG.XB.XXX.CLLDXX
- Mated with: PSG/PAG/MSG series

Note: "X" refers to part number definition on page 018

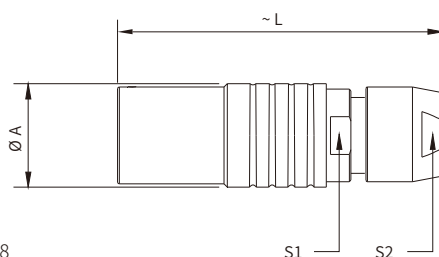

■ General Information



Ambient temperature:	-55°C~+250°C
Mating endurance:	>5000 cycles
Insulator:	PEEK
Connector contacts:	Brass with gold plated
Housing:	Brass with Cr plated

Insulation resistance:	≥ 100MΩ
IP rating:	IP 50
Shielding efficiency:	at 10MHz>75dB / at 1GHz>40dB
Salt spray corrosion test:	>144h

Size	Dimensions(mm)			
	A	L	S1	S2
00	6.8	26.0	5.5	5.0
0B	9.5	35.5	8.0	7.0
1B	12.5	40.5	10.0	9.0
2B	16.5	47.0	13.0	12.0
3B	19.0	56.0	15.0	15.0
4B	26.0	77.0	21.0	20.0

AEG Free Straight Socket, Key(G), Flexible Installation

- Connector series: AEG
 - Contact: Female
 - Key: G(More keys, refer to page 046)
 - Locking type: Self-locking
 - Orientation type: Straight
 - Part No.: AEG.XB.XXX.CLLDXX
 - Mated with: PSG/PAG/PCG/PBG/MSG/PLG/PPG
- Note: "X" refers to part number definition on page 018

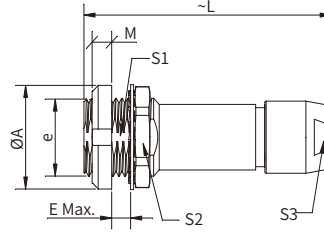

General Information



Ambient temperature:	-55°C~+250°C
Endurance:	>5000 cycles
Insulator:	PEEK
Connector contacts:	Brass with gold plated
Housing:	Brass with Cr plated

Insulation resistance:	≥ 100MΩ
IP rating:	IP 50
Shielding efficiency:	at 10MHz>75dB/at 1GHz>40dB
Salt spray corrosion test:	>144h

Size	Dimensions(mm)								
	A	e	E	L	M	S1	S2	S3	
00	10.0	M7*0.5	5.3	26.0	2.5	6.3	9.0	5.0	
0B	12.0	M9*0.6	5.0	35.5	2.5	8.2	11.0	7.0	
1B	16.0	M12*1.0	5.0	40.5	3.5	10.5	14.0	9.0	
2B	20.0	M15*1.0	6.5	47.0	3.5	13.5	17.0	12.0	
3B	24.0	M18*1.0	9.0	56.0	4.5	16.5	22.0	14.0	
4B	35.0	M25*1.0	10.0	76.0	4.5	23.5	30.0	20.0	

Panel cut-out (page 180)

PRG Fixed Straight Socket, Key(G), Cable Collet

- Connector series: PRG
 - Contact: Female
 - Key: G(More keys, refer to page 046)
 - Locking type: Self-locking
 - Orientation type: Straight
 - Part No.: PRG.XB.XXX.CLLDXX
 - Mated with: PSG/MSG/PLG/PPG series
- Note: "X" refers to part number definition on page 018

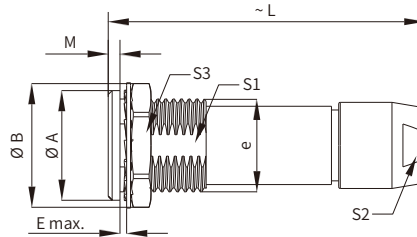

General Information



Ambient temperature:	-55°C~+250°C
Mating endurance:	>5000 cycles
Insulator:	PEEK
Connector contacts:	Brass with gold plated
Housing:	Brass with Cr plated

Insulation resistance:	≥ 100MΩ
IP rating:	IP 50
Shielding efficiency:	at 10MHz>75dB / at 1GHz>40dB
Salt spray corrosion test:	>144h

Size	Dimensions(mm)									
	A	B	e	E	M	L	S1	S2	S3	
00	8	10.2	M7*0.5	6.5	1.0	26.0	6.3	5	9	
0B	10	12.4	M9*0.6	7.0	1.2	35.5	8.2	7	11	
1B	14	15.8	M12*1.0	7.5	1.5	40.5	10.5	9	14	
2B	18	19.2	M15*1.0	8.5	1.8	47.0	13.5	12	17	
3B	22	25.0	M18*1.0	11.5	2.0	56.0	16.5	14	22	

Panel cut-out (page 180)

FKG Elbow Socket For Printed Circuit, Key(G)

- Connector series: FKG
- Contact: Female
- Key: G(More keys, refer to page 046)
- Locking type: Self-locking
- Orientation type: Angled
- Part No.: FKG.XB.XXX.HLN
- Mated with: PSG/PLG/PFG/PAG/PCG/PBG/PVG/MSG/PPG

Note: "X" refers to part number definition on page 018

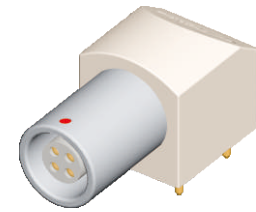
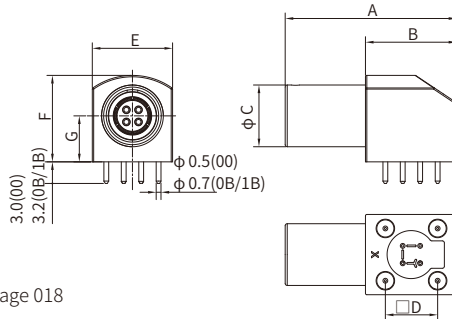

General Information

Ambient temperature:	-55°C ~ + 250°C	Housing:	Brass with Cr plated
Endurance:	>5000 cycles	Insulator resistance:	≥100MΩ
Insulator:	PEEK	IP rating:	IP 50
Connector contacts:	Brass with gold plated	Shielding efficiency:	at 10MHz>75dB/at 1GHz>40dB
Coupling nut/screw:	Brass with Cr plated	Salt spray corrosion test:	>144h

Size	Dimensions(mm)						
	A	B	C	D	E	F	G
00	19.0	8.7	6.8	5.08	7.1	7.0	3.5
0B	25.0	13.3	9.0	7.62	11.7	12.7	6.7
1B	27.0	13.3	11.0	7.62	12.6	14.0	7.5

PDG Straight Plug, Short Version, Key(G)

- Connector Series: PDG
- Contact: Male
- Key: G(More keys, refer to page 046)
- Locking type: Self-locking
- Orientation type: Straight
- Part No.: PDG.XB.XXX.CLADXX
- Mated with: FSG/SFG/SRG/SEG/FBG/PRG/ASG

Note: "X" refers to part number definition on page 018

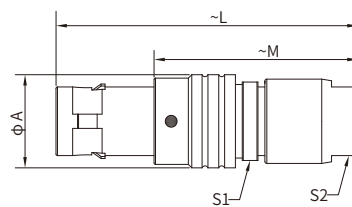

General Information

Ambient temperature:	-55 °C ~ + 250°C	Housing:	Brass with Cr plated
Endurance:	>5000 cycles	Insulator resistance:	≥100MΩ
Insulator:	PEEK	IP rating:	IP 50
Connector contacts:	Brass with gold plated	Shielding efficiency:	at 10MHz>75dB/at 1GHz>40dB
Coupling nut/screw:	Brass with Cr plated	Salt spray corrosion test:	>144h

Size	Dimensions(mm)				
	A	L	M	S1	S2
0B	9.5	32.0	22.0	8.0	7.0

■ SVG Fixed Straight Socket, Key(G), Front Fasten

- Connector Series: SVG
- Contact: Female
- Key: G(More keys, refer to page 046)
- Locking type: Self-locking
- Orientation type: Straight
- Part No.: SVG.xB.3xx.CLLPV
- Mated with: PSG/MSG/PLG/PPG

Note: "X" refers to part number definition on page 018

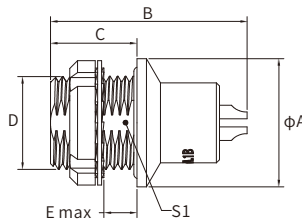

■ General Information

Ambient temperature:	-20°C ~ + 100°C
Endurance:	>5000 cycles
Insulator:	PEEK
Connector contacts:	Brass with gold plated
Coupling nut/screw:	Brass with Cr plated

Housing:	Brass with Cr plated
Insulator resistance:	≥100MΩ
Leakage rate(He):	<10 ⁻⁷ mbar.l.s ⁻¹
Shielding efficiency:	at 10MHz>75dB/at 1GHz>40dB
Salt spray corrosion test:	>144h

Size	Dimensions(mm)					
	A	B	D	C	E	S1
00	11	18.2	M7x0.5	6.0	2.5	6.3
0B	13	20.2	M9x0.6	9.0	5.5	8.2
1B	16.5	26.6	M12x1.0	11.0	5.5	10.5
2B	20	31.6	M15x1.0	9.6	5.5	13.5

Panel cut-out (page 180)

■ FQG Six Petal Socket, Key(G), Front Fastened

- Connector series: FQG
- Contact: Female
- Key: G(More keys, refer to page 046)
- Locking type: Self-locking
- Orientation type: Straight
- Part No.: FQG.1B.3XX.CLLPV
- Mated with: PQG.1B.3XX.CLACXX(Z)

Note: "X" refers to part number definition on page 018

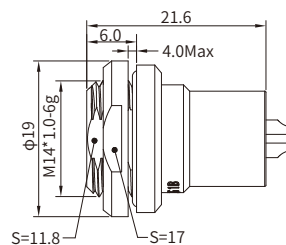

■ General Information

Ambient temperature:	-20°C~+100°C
Endurance:	>5000 cycles
Insulator:	PEEK
Connector contacts:	Brass with gold plated
Coupling nut/screw:	Brass with Cr plated

Housing:	Brass with Cr plated
Insulator resistance:	≥100MΩ
IP rating:	IP 68
Shielding efficiency:	at 10MHz>75dB/at 1GHz>40dB
Salt spray corrosion test:	>144h

■ PQG Six Petal Plug, Key(G), Cable Collet

- Connector series: PQG
- Contact: Male
- Key: G(More keys, refer to page 046)
- Locking type: Self-locking
- Orientation type: Straight
- Part No.: PQG.1B.3XX.CLACXX(Z)
- Mated with: FQG.1B.3XX.CLLPV

Note: "X" refers to part number definition on page 018

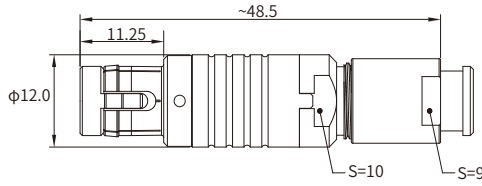

■ General Information

Ambient temperature:	-55°C~+200°C
Endurance:	>5000 cycles
Insulator:	PEEK
Connector contacts:	Brass with gold plated
Coupling nut/screw:	Brass with Cr plated

Housing:	Brass with Cr plated
Insulator resistance:	≥100MΩ
IP rating:	IP 68
Shielding efficiency:	at 10MHz>75dB/at 1GHz>40dB
Salt spray corrosion test:	>144h

■ PSG (Coaxial+Low Voltage), Straight Plug, Key(G), Cable Collet

- Connector series: PSG
- Contact: Male
- Locking type: Self-locking
- Orientation type: Straight
- Part No.: PSG.2B.810.CLADXX
- Mated with: FSG series

Note: "X" refers to part number definition on page 018

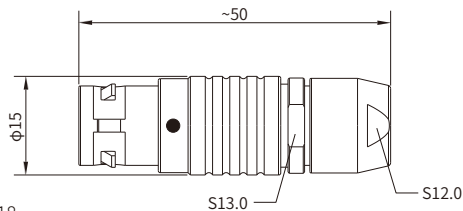

■ General Information

Ambient temperature:	-55°C ~ + 250°C
Endurance:	>5000 cycles
Insulator:	PEEK
Connector contacts:	Brass with gold plated

Housing:	Brass with Cr plated
IP rating:	IP50
Shielding efficiency:	at 10MHz>75dB/at 1GHz>40dB
Salt spray corrosion test:	>144h

Impedance(Ω)	Coaxial					Low voltage			
	φB(mm) Min.	φB(mm) Max.	Cable OD(mm) Max.	VSWR (F=GHz)	Cable standard	φA(mm)	Contact type	Rated voltage (kV)	Rated current (A)
50	0.50	0.58	1.65	1.04+0.1f	RG178 B/U	0.70	Solder	0.3	7

FSG (Coaxial+Low Voltage), Fixed Socket, Key(G)

- Connector series: FSG
- Contact: Female
- Locking type: Self-locking
- Orientation type: Straight
- Part No.: FSG.2B.810.CLL
- Mated with: PSG series

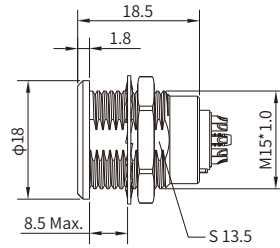

General Information

Ambient temperature:	-55°C ~ + 250°C
Endurance:	>5000 cycles
Insulator:	PEEK
Connector contacts:	Brass with gold plated

Housing:	Brass with Cr plated
IP rating:	IP50
Shielding efficiency:	at 10MHz>75dB/at 1GHz>40dB
Salt spray corrosion test:	>144h

Impedance(O)	Coaxial					Low voltage			
	φB(mm) Min.	φB(mm) Max.	Cable OD(mm) Max.	VSWR (F-GHZ)	Cable standard	φA(mm)	Contact type	Rated voltage (KV)	Rated current (A)
50	0.50	0.58	1.65	1.04+0.1f	RG178 B/U	0.70	Solder	0.3	7

Panel cut-out (page 180)

FSG Fixed Socket, Multi Coaxial or Fluidic Contact Mixed + LV , Key(G) or Keys(A...F and R)

- Connector series: FSG
- Contact: Female(Mixed)
- Locking type: Self locking
- Orientation type: Socket
- Part No.:FSG.3B.8xx.CLL
- Mated with: PSG/PLG/MSG

Note: Fluid contact is type P1 , see page 014

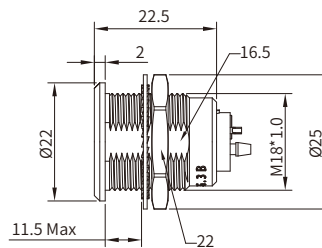

General Information

Ambient temperature:	-55°C ~ + 250 °C (Fluidic -20°C ~ + 125°C)
Endurance:	>3000 cycles (Fluidic>1000 cycles)
Insulator:	PEEK
Connector contacts:	Brass with gold plated
Housing:	Brass with Cr plated

O-ring:	FPM
Insulator resistance:	≥100MΩ
IP rating:	IP 50
Shielding efficiency:	at 10MHz>75dB/at 1GHz>40dB
Salt spray corrosion test:	>144h

NO	Coaxial/Fluidic ¹⁾			LV					
	Contact quality	Impedance	Contact quality	φA(mm)	Contact type	Test Voltage (Kv rms)	Test voltage (Kv DC)	Rated current (A)	
846	2	50Ω/-	6	0.9	Solder	0.9	1.3	10	
862	3	50Ω/-	2	0.9	Solder	1.10	1.60	9	

1):Coaxial and fluid can be used interchangeably

■ PSG Straight Plug, (Multi Coaxial or Fluidic Contact Mixed + LV , Key(G) or Keys(A...F and R), Cable Collet

- Connector series: PSG
- Contact: Male(Mixed)
- Locking type: Self locking
- Orientation type: Socket
- Part No.: PSG.3B.8xx.CLADxx
- Mated with: FSG/SRG/FBG

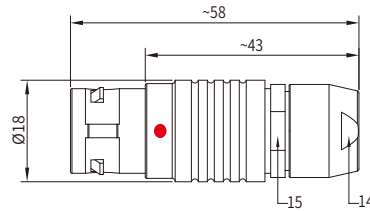

Note: Fluid contact is type P1 , see page 014

■ General Information

Ambient temperature:	-55°C ~ + 250 °C (Fluidic -20°C ~ + 125°C)	O-ring:	FPM
Endurance:	>3000 cycles (Fluidic>1000 cycles)	Insulator resistance:	≥100MΩ
Insulator:	PEEK	IP rating:	IP 50
Connector contacts:	Brass with gold plated	Shielding efficiency:	at 10MHz>75dB/at 1GHz>40dB
Housing:	Brass with Cr plated	Salt spray corrosion test:	>144h

Diagram	Coaxial/Fluidic ¹⁾			LV					
	NO	Contact quality	Impedance	Contact quality	ΦA(mm)	Contact type	Test Voltage (Kv rms)	Test voltage (Kv DC)	Rated current (A)
	846	2	50Ω/-	6	0.9	Solder	0.9	1.3	10
	862	3	50Ω/-	2	0.9	Solder	1.10	1.60	9

1):Coaxial and fluid can be used interchangeably

■ FSG Straight Socket, Key(G), Fluidic Type

- Connector series: FSG.2B.013
- Contact: Female
- Key: G(More keys, refer to page 046)
- Locking type: Self-locking
- Orientation type: Straight
- Part No.: FSG.2B.013.CLL
- Mated with: PSG.2B.013

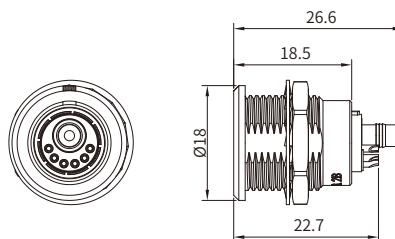

■ General Information

Ambient temperature:	-55°C ~ + 250°C	Housing:	Brass with Cr plated
Endurance:	>1000 cycles	Insulator resistance:	≥100MΩ
Insulator:	PEEK	IP rating:	IP 50
Connector contacts:	Brass with gold plated	Fluid ter. suitability pipe:	ID3.0
Coupling nut/screw:	Brass with nickel plated	Max. working pressure (bars):	6

■ PSG Straight Plug, Key(G), Fluidic Type

- Connector series: PSG.2B.013
- Contact: Male
- Key: G(More keys, refer to page 046)
- Locking type: Self-locking
- Orientation type: Straight
- Part No.: PSG.2B.013.CLACXXZ
- Mated with: FSG.2B.013

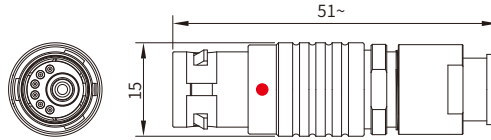

■ General Information

Ambient temperature:	-55°C ~ + 250°C
Endurance:	>1000 cycles
Insulator:	PEEK
Connector contacts:	Brass with gold plated
Coupling nut/screw:	Brass with nickel plated

Housing:	Brass with Cr plated
Insulator resistance:	≥100MΩ
IP rating:	IP 50
Fluid ter. suitability pipe:	ID3.0
Max. working pressure (bars):	6

■ Fixed Coupler Nut Fixing Key(G)or Keys(A,B,J,K and L) at The Flange End and Key(G) or Keys (A,B,J,K and L) at The Other End, Watertight Or Vacuumtight

- Connector series: TXX
- Contact: See table
- Coding: See as below
- Locking type: Self-locking
- Orientation type: Straight
- Part No.: TXX.XB.3XX.CLLPV
- Mated with: PSX.XB.3XX

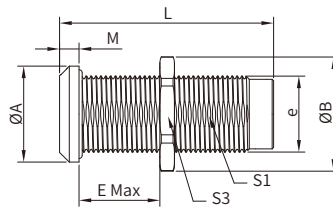

Note: "X" refers to part number definition on page 018

■ General Information

Ambient temperature:	-20°C ~ + 100°C
Endurance:	>5000 cycles
Insulator:	PEEK
Connector contacts:	Brass with gold plated
Coupling nut/screw:	Brass with nickel plated

Housing:	Brass with Cr plated
Insulator resistance:	≥100MΩ
IP rating:	IP 68(Panel)
Gas tightness	See table
Salt spray corrosion test:	>144h

Reference		Contacts	Dimensions(mm)								Vacuumtight (bar)
Model	Series	Type	A	B	e	E	L	M	S1	S3	
TGJ	0B	female-male	14	13.8	M10x0.75	17	34	2.0	9.0	12	60
TJG	0B	male-female									
TGJ	1B	female-male	17	15.8	M12x1.00	28	39	2.5	10.5	14	60
TJG	1B	male-female									
TGJ	2B	female-male	20	21.5	M16x1.00	25	44	4.0	15.0	19	40
TJG	2B	male-female									
TGJ	3B	female-male									
TJG	3B	male-female	25	27.0	M20x1.00	30	53	4.0	18.5	24	30
TAK	3B	female-male									
TBL	3B	female-male									
TAK	4B	female-male									
TBL	4B	male-female	34	34	M25x1.00	50	65	4.0	23.5	30	15
TGJ	4B	female-male									
TJG	4B	male-female									

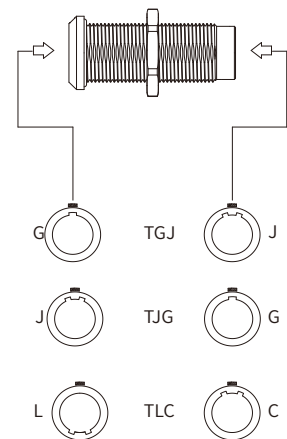

■ CHG Plug Caps, Nut Fixing or Flange

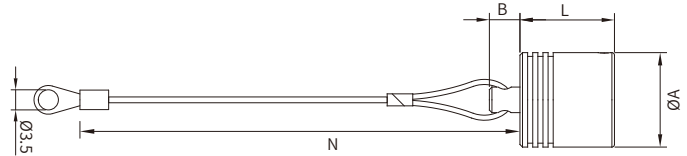

■ General Information

Ambient temperature:	maximum 135 °C
Endurance:	>5000 cycles
Body material:	Brass with nickel plated
Lanyard material:	Stainless steel

Crimp ferrule material:	Brass with nickel plated
Ip rating:	IP50
Salt spray corrosion test:	>144h

Part number	Size	Dimensions(mm)			
		A	B	L	N
CHG.00.100.PCS	00	7.5	4	10.0	100
CHG.0B.100.PCS	0B	9.5	5	12.2	120
CHG.1B.100.PCS	1B	12.0	6	13.8	120
CHG.2B.100.PCS	2B	15.0	6	15.0	150
CHG.3B.100.PCS	3B	18.5	6	18.5	150
CHG.4B.100.PCS	4B	25.0	10	20.2	200

Note: This cap is available only with an alignment key (G). The last letter "S" of part number stands for the material of the O-ring (silicone rubber). O-ring's made from FPM are also available; if required, replace the letter "S" by "V"

■ CFG Plug Caps, Sliding Loop

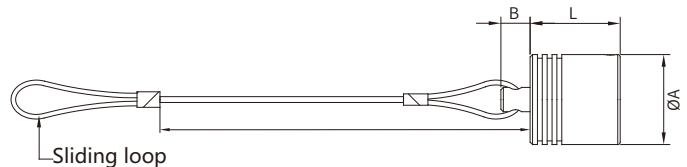

■ General Information

Ambient temperature:	maximum 135 °C
Endurance:	>5000 cycles
Body material:	Brass with nickel plated
Lanyard material:	Stainless steel

Crimp ferrule material:	Brass with nickel plated
Ip rating:	IP50
Salt spray corrosion test:	>144h

Part number	Size	Dimensions(mm)			
		A	B	L	N
CFG.00.100.PCS	00	7.5	4	10.0	100
CFG.0B.100.PCS	0B	9.5	5	12.2	120
CFG.1B.100.PCS	1B	12.0	6	13.8	120
CFG.2B.100.PCS	2B	15.0	6	15.0	150
CFG.3B.100.PCS	3B	18.5	6	18.5	150
CFG.4B.100.PCS	4B	25.0	10	20.2	200

Note: This cap is available only with an alignment key (G). The last letter "S" of part number stands for the material of the O-ring (silicone rubber). O-ring's made from FPM are also available; if required, replace the letter "S" by "V"

■ CRE Blanking Caps For Fixed Sockets

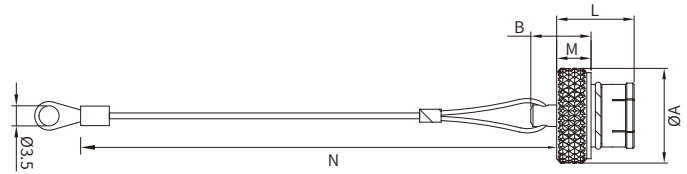

■ General Information

Ambient temperature:	maximum 135 °C
Endurance:	>5000 cycles
Body material:	Brass with nickel plated
Lanyard material:	Stainless steel

Crimp ferrule material:	Brass with nickel plated
Ip rating:	IP50
Salt spray corrosion test:	>144h

Part number	Size	Dimensions(mm)				
		A	B	L	M	N
CRE.00.200.NAS	00	8	7.5	8.5	3.5	100
CRE.0B.200.NAS	0B	10	9.5	10.5	4.5	120
CRE.1B.200.NAS	1B	14	11.5	12.5	5.5	120
CRE.2B.200.NAS	2B	18	12.0	14.0	6.0	150
CRE.3B.200.NAS	3B	22	14	18.0	8.0	150
CRE.4B.200.NAS	4B	28	20.0	23.0	10.0	200

Note: This cap is available only with an alignment key (G). The last letter "S" of part number stands for the material of the O-ring (silicone rubber). O-ring's made from FPM are also available; if required, replace the letter "S" by "V"

■ CRF Blanking Caps For Fixed Sockets, Sliding Loop

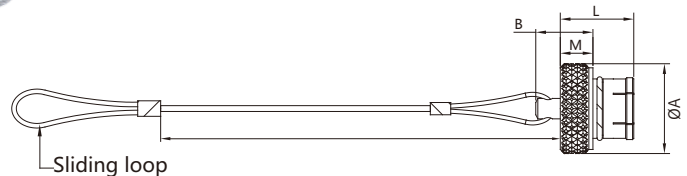

■ General Information

Ambient temperature:	maximum 135 °C
Endurance:	>5000 cycles
Body material:	Brass with nickel plated
Lanyard material:	Stainless steel

Crimp ferrule material:	Brass with nickel plated
Ip rating:	IP50
Salt spray corrosion test:	>144h

Part number	Size	Dimensions(mm)				
		A	B	L	M	N
CRF.00.200.NAS	00	8	7.5	8.5	3.5	100
CRF.0S.200.NAS	0B	10	9.5	10.5	4.5	120
CRF.1S.200.NAS	1B	14	11.5	12.5	5.5	120
CRF.2S.200.NAS	2B	18	12.0	14.0	6.0	150
CRF.3S.200.NAS	3B	22	14	18.0	8.0	150
CRF.4S.200.NAS	4B	28	20.0	23.0	10.0	200

Note: This cap is available only with an alignment key (G). The last letter "S" of part number stands for the material of the O-ring (silicone rubber). O-ring's made from FPM are also available; if required, replace the letter "S" by "V"

■ Electrical & Mechanical Data

PS · G · 0B · 305 · C L A D 42

Insert configuration

Size	Part.No	Pin Count	Pin layout From the direction of solder		Contact Dim (mm)	Rated current (A)	Contact type			Test voltage(KV rms)			
			Male	Female			Solder	Print	Crimp	Solder contact		Crimp contact	
										Contact and Contact	Contact and Shell	Contact and Contact	Contact and Shell
00	302	02			0.5	5.0	●	●	●	1.00	0.95	1.15	1.20
	303	03			0.5	3.0	●	●	●	0.80	0.95	1.35	1.10
	304	04			0.5	2.0	●	●	●	0.80	0.65	1.05	1.05
	305	05			0.35	1.7	●	-	-	0.70	1.00	-	-
	306	06			0.35	1.5	●	-	-	0.60	0.75	-	-
0B	302	02			0.9	10.0	●	●	●	1.00	1.05	1.45	1.20
	303	03			0.9	8.0	●	●	●	1.20	0.90	1.70	1.60
	304	04			0.7	7.0	●	●	●	0.85	0.70	1.35	1.10
	305	05			0.7	6.5	●	●	●	1.00	0.70	1.25	1.20
	306	06			0.5	2.5	●	●	○	0.85	0.65	1.40	1.20
	307	07			0.5	2.5	●	●	○	0.80	0.70	1.40	1.20
	309	09			0.5	2.0	●	●	○	0.60	0.50	1.00	0.85
	312	12			0.35	1.5	●	●	-	0.80	1.00	-	-

■ Electrical & Mechanical Data

PS · G · 0B · 305 · C L A D 42

Insert configuration

Size	Part.No	Pin Count	Pin layout From the direction of solder		Contact Dim (mm)	Rated current (A)	Contact type			Test voltage(KV rms)			
			Male	Female			Solder	Print	Crimp	Solder contact		Crimp contact	
										Contact and Contact	Contact and Shell	Contact and Contact	Contact and Shell
1B	302	02			1.3	15.0	●	●	●	1.50	1.35	1.70	1.45
	303	03			1.3	12.0	●	●	●	1.30	1.55	1.60	1.85
	304	04			0.9	10.0	●	●	●	1.35	1.45	1.70	1.80
	305	05			0.9	9.0	●	●	●	1.25	1.15	1.30	1.55
	306	06			0.7	7.0	●	●	●	1.05	1.20	1.35	1.45
	307	07			0.7	7.0	●	●	●	0.95	1.05	1.45	1.45
	308	08			0.7	5.0	●	●	●	0.95	1.15	1.30	1.30
	310	10			0.5	2.5	●	●	○	0.90	1.50	1.20	1.80
	314	14			0.5	2.0	●	●	○	0.80	1.20	0.95	1.60
	316	16			0.5	1.5	●	●	○	0.80	1.25	0.95	1.60

It is proposed according to the following ratio : Operating Voltage (Us) = Test voltage(Ue) / 3

● First Recommendation ○ Special order alternative

Caution:

For a number of applications, safety requirements for electrical appliances are more severe with regard to operating voltage.

In such cases operating voltage is defined according to creepage distance and air clearance) between live parts.

■ Electrical & Mechanical Data

Size	Part.No	Pin Count	Pin layout From the direction of solder		Contact Dim (mm)	Rated current (A)	Contact type			Test voltage(KV rms)			
			Male	Female			Solder	Print	Crimp	Solder contact		Crimp contact	
										Contact and Contact	Contact and Shell	Contact and Contact	Contact and Shell
2B	302	02			2.0	30.0	●	○	○	2.10	1.75	2.85	2.70
	303	03			1.6	17.0	●	○	○	2.40	1.85	1.90	1.90
	304	04			1.3	15.0	●	●	●	1.85	1.85	2.20	2.20
	305	05			1.3	14.0	●	●	●	1.75	1.60	2.15	2.15
	306	06			1.3	12.0	●	●	●	1.35	1.45	2.00	2.35
	307	07			1.3	11.0	●	●	●	1.75	1.60	1.95	2.15
	308	08			0.9	10.0	●	●	●	1.50	1.25	1.95	1.95
	310	10			0.9	8.0	●	●	●	1.45	1.30	1.80	2.10
	312	12			0.7	7.0	●	●	●	1.25	1.35	1.65	2.00
	314	14			0.7	6.5	●	●	●	1.15	1.35	1.55	1.95
	316	16			0.7	6.0	●	●	●	0.95	1.25	1.55	1.75
	318	18			0.7	5.5	●	●	●	0.85	1.20	1.45	2.10
	319	19			0.7	5.0	●	●	●	0.95	1.25	1.55	1.65
	326	26			0.5	2.0	●	●	—	0.95	1.30	1.20	1.80
	332	32			0.5	1.5	●	●	—	0.80	1.20	0.95	1.60

It is proposed according to the following ratio : Operating Voltage (Us) = Test voltage(Ue) / 3

● First Recommendation ○ Special order alternative

Caution:

For a number of applications, safety requirements for electrical appliances are more severe with regard to operating voltage.

In such cases operating voltage is defined according to creepage distance and air clearance) between live parts.

Electrical & Mechanical Data

Size	Part.No	Pin Count	Pin layout From the direction of solder		Contact Dim (mm)	Rated current (A)	Contact type			Test voltage(KV rms)			
			Male	Female			Solder	Print	Crimp	Solder contact		Crimp contact	
										Contact and Contact	Contact and Shell	Contact and Contact	Contact and Shell
3B	302	02			3.0	35.0	●	○	●	2.10	1.55	2.30	1.80
	303	03			2.0	25.0	●	●	●	1.90	1.50	3.20	2.65
	304	04			2.0	19.0	●	●	●	1.45	1.25	2.50	2.20
	305	05			1.6	19.0	●	●	●	1.90	1.25	2.40	1.75
	306	06			1.6	17.0	●	●	●	1.60	1.15	1.90	1.80
	307	07			1.6	15.0	●	●	●	1.70	1.25	2.00	2.05
	308	08			1.3	13.0	●	●	●	1.65	1.15	1.85	1.75
	514 (Cat 6A insulator)	08			0.7	10	○	○	●	-	-	1.5	1.5
	309	09			8x1.3 1x2.0	6.0 15.0	●	●	●	1.35 1.35	1.05 1.05	1.10 1.10	1.05 1.05
	310	10			1.3	12.0	●	●	●	1.25	0.90	1.50	1.80
	312	12			0.9	9.0	●	●	●	1.45	1.00	1.65	1.85
	314	14			0.9	9.0	●	●	●	1.20	1.20	1.80	1.65
	316	16			0.9	8.0	●	●	●	1.20	0.85	1.80	1.50
	318	18			0.9	7.0	●	●	●	1.20	1.05	1.85	1.60
	320	20			0.7	6.0	●	●	●	1.00	0.90	1.35	1.55
	322	22			0.7	5.5	●	●	●	1.00	0.90	1.70	1.45
	324	24			0.7	4.0	●	●	●	0.95	0.80	1.35	1.35
	326	26			0.7	4.0	●	●	●	0.95	0.70	1.50	1.30
	330	30			0.7	3.5	●	●	●	0.80	0.70	1.35	1.20

It is proposed according to the following ratio : Operating Voltage (Us) = Test voltage(Ue) / 3

● First Recommendation ○ Special order alternative

Caution:

For a number of applications, safety requirements for electrical appliances are more severe with regard to operating voltage.

In such cases operating voltage is defined according to creepage distance and air clearance) between live parts.

■ Electrical & Mechanical Data

Size	Part.No	Pin Count	Pin layout From the direction of solder		Contact Dim (mm)	Rated current (A)	Contact type			Test voltage(KV rms)			
			Male	Female			Solder	Print	Crimp	Solder contact		Crimp contact	
										Contact and Contact	Contact and Shell	Contact and Contact	Contact and Shell
4B	304	04			3.0	30.0	●	○	●	2.10	1.50	1.80	1.20
	306	06			2.0	24.0	●	○	●	2.00	1.75	2.75	2.40
	307	07			2.0	20.0	●	○	●	2.00	1.80	1.50	1.35
	310	10			1.6	17.0	●	○	●	1.85	1.30	1.90	1.95
	312	12			1.3	12.0	●	○	●	1.45	1.60	1.90	1.85
	316	16			0.9	10.0	●	●	●	1.35	1.50	2.30	2.10
	320	20			0.9	8.0	●	●	●	1.35	1.00	1.05	0.95
	324	24			0.9	7.0	●	●	●	1.20	1.45	1.80	2.05
	330	30			0.9	5.0	●	●	●	0.95	0.85	1.75	1.45
	340	40			0.7	2.0	●	●	●	0.90	0.90	1.30	1.30
	348	48			0.7	1.5	●	●	●	0.70	0.70	1.00	1.00

It is proposed according to the following ratio : Operating Voltage (Us) = Test voltage(Ue) / 3

● First Recommendation ○ Special order alternative

Caution:

For a number of applications, safety requirements for electrical appliances are more severe with regard to operating voltage.

In such cases operating voltage is defined according to creepage distance and air clearance) between live parts.

Alignment Key, Metal Material&plate

PS · G · 0B · 305 · C L A D 42

Alignment key:

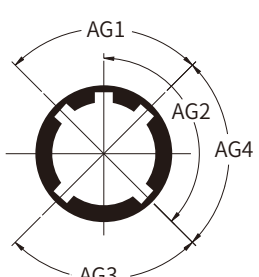

Front view of socket

Code	No. of keys	Series							Contact type		Notes	
		Angles	00	0B	1B	Angles	2B	3B	Plug	Socket		
G	1	-	0°	0°	0°	-	0°	0°	male	female	●	
A	2	AG1	30°	30°	30°	AG1	30°	30°	male	female	●	
B	2		60°	60°	60°		45°	45°	male	female	●	
C	2		-	90°	90°		60°	60°	male	female	●	
D	2	AG2	-	135°	135°	AG3	95°	95°	male	female	○	
E	2		-	145°	145°		AG2	120°	120°	male	female	○
F	2		-	155°	155°			145°	145°	male	female	○
J	2	AG3	45°	45°	45°	AG1	37.5°	37.5°	female	male	●	
K	2		-	70°	70°		52.5°	52.5°	female	male	○	
L	2		-	80°	80°		AG3	70°	70°	female	male	○
M	2	AG4	-	110°	-	-	-	-	female	male	○	
Y	3	-	-	-	-	AG2	112.5°	126°	male	female	●	
		-	-	-	-	AG3	100°	102°				

Metal material&plate:

Refrence	Out shell+collet nut		Latch sleeve+earth crown		Other metallic components		Remarks	Notes
	Material	Surftreatment	Material	Surftreatment	Material	Surftreatment		
C	Brass	Chrome	Brass-bronze	Nickel	Brass	Nickel		●
N	Brass	Nickel	Brass-bronze	Nickel	Brass	Nickel		○
K	Brass	Black Chrome	Brass-bronze	Nickel	Brass	Nickel		●
S	Stainless steel	-	Brass-bronze	Nickel	Brass	Nickel		●
P	PSU	-	Brass-bronze	Nickel	Brass	Nickel	Available for some parts of B series	●
H	PPS/Brass	-/Nickel	Brass-bronze	Nickel	Brass	Nickel	Only for elbow sockets (B series)	●

● First Recommendation ○ Special order alternative

■ Insulator & Contact Type

PS · G · 0B · 305 · C L A D 42

Insulator&contact type

	Y	L
Insulator material	PEEK	PEEK
Contact type	Crimp	Solder or print

Contacts reference for plugs free or fixed sockets

Contact type	Reference		Contact (mm)		Conductor Size					
					Solid		Stranded			
	Male	Female	Pin OD	Wire OD	AWG max.	Section max. (mm ²)	AWG		Section (mm ²)	
						min.	max.	min.	max.	
Solder	A	L	0.5	0.4	28	0.09		30		0.05
			0.5	0.45	28	0.09		28		0.09
			0.7	0.8	22	0.34		22		0.34
			0.9	0.8	22	0.34		22		0.34
			1.3	1.0	20	0.50		20		0.50
			1.6	1.4	16	1.00		18		1.00
			2.0	1.8	14	1.50		16		1.50
			3.0	2.7	10	4.00		12		4.00
Crimp	C	M	0.5	0.45			32	28	0.035	0.09
	C	M	0.7	0.80			26	22	0.140	0.34
	B	P	0.7	0.45			32	28	0.035	0.09
	C	M	0.9	1.10			24	20	0.250	0.50
	B	P	0.9	0.80			26	22	0.140	0.34
	G	U	0.9	0.45			32	28	0.035	0.09
	C	M	1.3	1.40			20	18	0.500	1.00
	B	P	1.3	1.10			24	20	0.250	0.50
	G	U	1.3	0.80			26	22	0.140	0.34
	C	M	1.6	1.90			18	14	1.000	1.50
	B	P	1.6	1.40			22	18	0.340	1.00
	C	M	2.0	2.40			16	12	1.500	2.50
	B	P	2.0	1.90			18	14	1.000	1.50
C	M	3.0	2.90			14	10	2.500	4.00	
Print	D	N								
Print Angled	W	V								

■ Collet Type

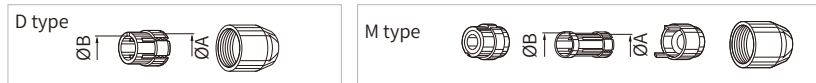
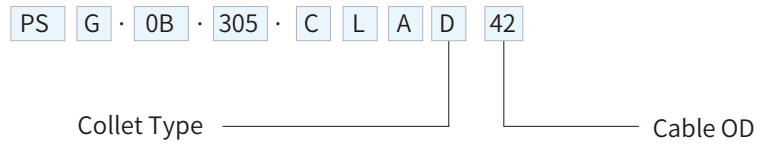

Series	Reference		Collet OD		Cable OD	
	Type	Code	A	B	max.	min.
00	D	17	1.7	-	1.6	1.1
	D	22	2.2	-	2.1	1.6
	D	27	2.7	-	2.6	2.1
	D	30	3.1	2.8	3.0	2.5
	D	35	3.5	2.8	3.4	2.9
0B	D	21	2.1	-	2.0	1.5
	D	31	3.1	-	3.0	2.1
	D	42	4.2	-	4.0	3.1
	D	52	5.2	4.7	5.0	4.1
	D	56	5.6	4.7	5.5	5.1 ^①
1B	M	27	2.7	-	2.6	2.2
	M	31	3.1	-	3.0	2.6
	D	42	4.2	-	4.0	3.1
	D	52	5.2	-	5.0	4.1
	D	62	6.2	-	6.0	5.1
	D	72	7.2	6.7	7.0	6.1
	D	76	7.6	6.7	7.5	7.1 ^①
2B	M	21	2.1	-	2.0	1.5
	M	31	3.1	-	3.0	2.1
	M	42	4.2	-	4.0	3.1
	D	52	5.2	-	5.0	4.1
	D	62	6.2	-	6.0	5.1

Series	Reference		Collet OD		Cable OD	
	Type	Code	A	B	max.	min.
2B	D	72	7.2	-	7.0	6.1
	D	82	8.2	-	8.0	7.1
	D	92	9.2	8.6	9.0	8.1
	D	99	9.9	8.6	9.7	9.1 ^①
3B	M	52	5.2	-	5.0	4.1
	D	62	6.2	-	6.0	5.1
	D	72	7.2	-	7.0	6.1
	D	82	8.2	-	8.0	7.1
	D	92	9.2	-	9.0	8.1
	D	10	10.2	-	10.0	9.1
	D	11	11.2	10.2	11.0	10.1
4B	D	12	11.9	10.2	11.7	11.1 ^①
	M	62	6.2	-	6.0	5.1
	M	72	7.2	-	7.0	6.1
	M	82	8.2	-	8.0	7.1
	M	92	9.2	8.6	9.0	8.1
	D	10	10.8	-	10.5	9.1
	D	12	12.3	-	12.0	10.6
	D	13	13.8	12.5	13.5	12.1
	D	15	15.3	12.5	15.0	13.6
	D	16	16.3	12.5	16.0	15.1

Note: All dimensions are in millimetres.

① These collets cannot be used for connector models with nut for fitting a bend relief.

K Series

Key Features:

- Security of the Push-Pull latching system
- Multipole types 2 to 32 contacts
- 360° screening for full emc shielding
- High packing density for space savings
- Watertight connection (IP 68)
- Solder, crimp or print (straight or angled) contacts
- Keying system (“G” key standard) for connector alignment
- Multiple key options to avoid cross mating of similar connectors



■ Part Section Showing Internal Components

Fixed Socket

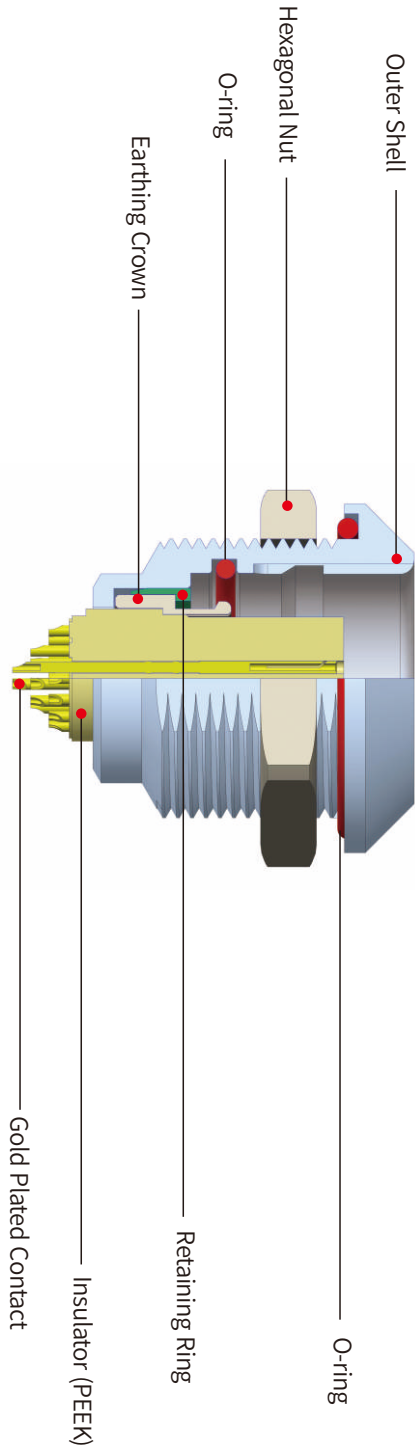

Straight Plug

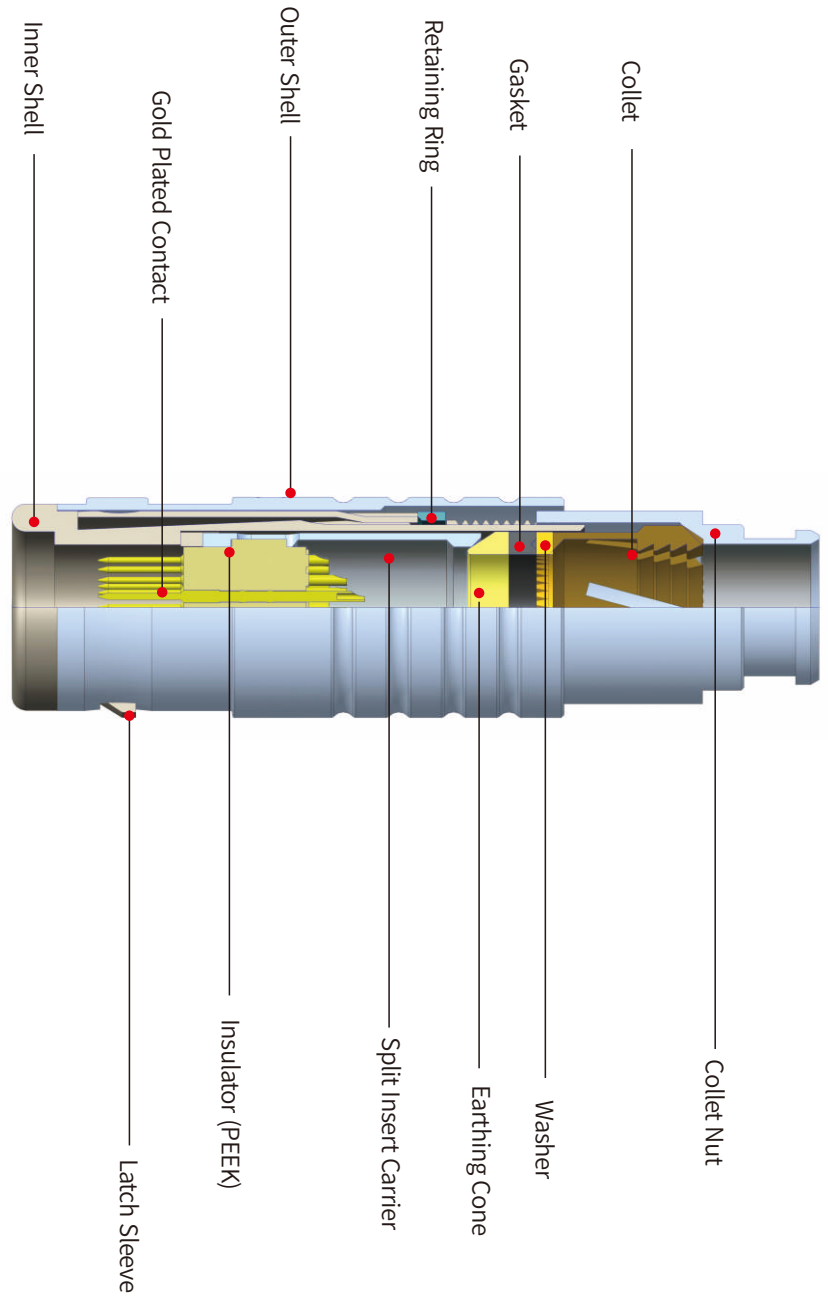

■ Part Number Definition

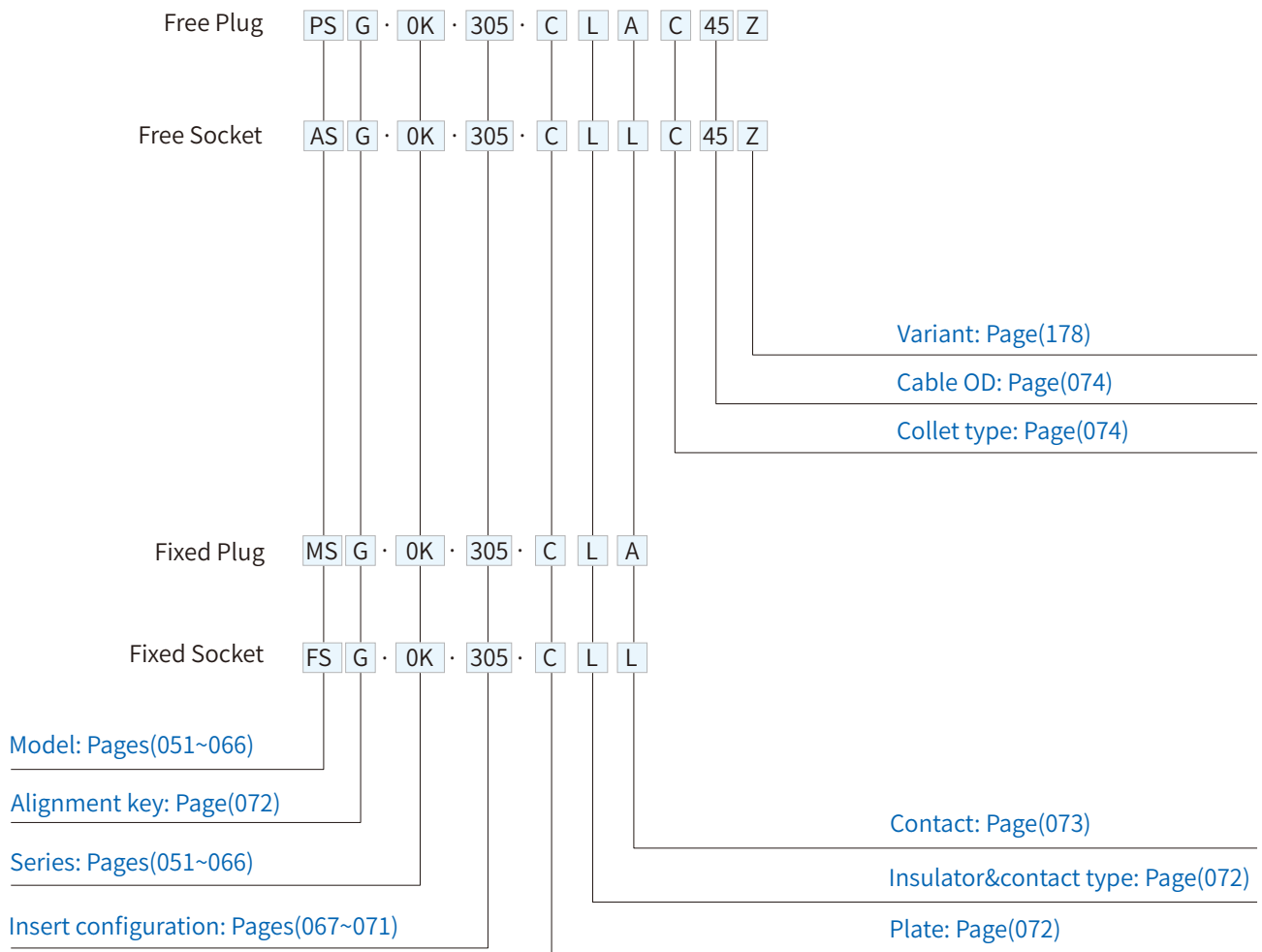

■ Part Number Example

Straight plug with cable collet:

PSG.0K.305.CLAC45=straight plug with key(G) and cable collet, 0K Series, multipole type with 5 contacts, chrome-plated brass outershell, PEEK insulator with male solder contacts, C type collet for 4.5mm diameter cable.

Straight plug with cable collet:

ASG.0K.305.CLLC45Z=free socket with key(G)and cable collet, 0K series, multipole type with 5 contacts, outershell in chrome-plated brass, PEEK insulator, female solder contacts, C type collet for 4.5mm diameter cable and nut for fitting a bend relief.

Fixed socket:

FSG.0K.305.CYM=fixed socket, nut fixing, with key(G), 0K series, multipole type with 5 contacts, outershell lchrome-plated brass, PEEK insulator, female crimp contacts.

■ PSG Straight Plug, Nut for Bend Relief, Key(G), Cable Collet

- Connector series: PSG
- Contact: Male
- Key: G(More keys, refer to page 072)
- Locking type: Self-locking
- Orientation type: Straight
- Part No.: PSG.XK.XXX.CLACXXZ
- Mated with: FSG/SRG series

Note: "X" refers to part number definition on page 051

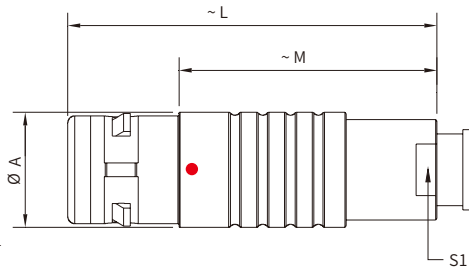

■ General Information



Ambient temperature:	-55°C~+200°C
Mating endurance:	>5000 cycles
Insulator:	PEEK
Connector contacts:	Brass with gold plated
Housing:	Brass with Cr plated

Seal/o-ring	Silicone
Insulation resistance:	≥ 100MΩ
IP rating:	IP 68
Shielding efficiency:	at 10MHz>95dB / at 1GHz>80dB
Salt spray corrosion test:	>144h

Size	Dimensions(mm)			
	A	L	M	S1
0K	11	34	23	7
1K	13	42	28	9
2K	16	52	36	12
3K	19	60	40	15
4K	25	70	49	19

■ PAG Angled Plug, Nut for Bend Relief, Key(G), Cable Collet

- Connector series: PAG
- Contact: Male
- Key: G(More keys, refer to page 072)
- Locking type: Self-locking
- Orientation type: Angled
- Part No.: PAG.XK.XXX.CLACXXZ
- Mated with: FSG/SRG series

Note: "X" refers to part number definition on page 051

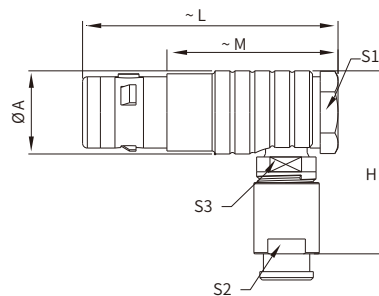

■ General Information



Ambient temperature:	-55°C~+200°C
Mating endurance:	>5000 cycles
Insulator:	PEEK
Connector contacts:	Brass with gold plated
Housing:	Brass with Cr plated

Seal/o-ring	Silicone
Insulation resistance:	≥ 100MΩ
IP rating:	IP 68
Shielding efficiency:	at 10MHz>95dB / at 1GHz>80dB
Salt spray corrosion test:	>144h

Size	Dimensions(mm)						
	A	L	M	H	S1	S2	S3
0K	11.5	36	23	28.5	10	8	8
1K	14.0	43	28	35.5	12	9	10
2K	17.5	51	36	40.0	15	12	13
3K	21.0	60	40	47.0	18	15	15

■ FSG Fixed Straight Socket, Key(G)

- Connector series: FSG
- Contact: Female
- Key: G(More keys, refer to page 072)
- Locking type: Self-locking
- Orientation type: Straight
- Part No.: FSG.XK.XXX.CLL
- Mated with: PSG series

Note: "X" refers to part number definition on page 051

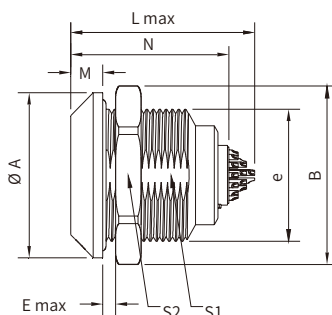

■ General Information



Ambient temperature:	-55°C~+200°C
Mating endurance:	>5000 cycles
Insulator:	PEEK
Connector contacts:	Brass with gold plated
Coupling nut/screw:	Brass with nickel plated
Housing:	Brass with Cr plated

Seal/o-ring	Silicone
Insulation resistance:	≥ 100MΩ
IP rating:	IP 68
Shielding efficiency:	at 10MHz>95dB / at 1GHz>80dB
Salt spray corrosion test:	>144h

Size	Dimensions(mm)								
	A	B	e	E	L	M	N	S1	S2
0K	18	19.2	M14*1.0	6.0	21.7	4.0	20.1	12.5	17
1K	20	21.5	M16*1.0	9.0	27.0	4.5	25.1	14.5	19
2K	25	27.0	M20*1.0	9.0	30.7	5.0	28.6	18.5	24
3K	31	34.0	M24*1.0	11.0	36.2	6.0	33.6	22.5	30
4K	37	39.5	M30*1.0	11.0	39.2	7.0	34.2	28.5	36

Panel Cut-out page 180; The dimension "N" depends on the number of contacts, detail information see page 185

■ FSG Fixed Straight Socket, Key(G), Contact for Printed Circuit

- Connector series: FSG
- Contact: Female
- Key: G(More keys, refer to page 072)
- Locking type: Self-locking
- Orientation type: Straight
- Part No.: FSG.XK.XXX.CLN
- Mated with: PSG/PAG series

Note: "X" refers to part number definition on page 051

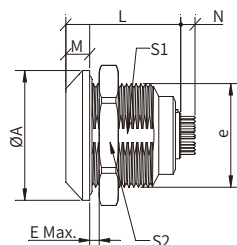

■ General Information



Ambient temperature:	-55°C~+200°C
Endurance:	>5000 cycles
Insulator:	PEEK
Connector contacts:	Brass with gold plated
Coupling nut/screw:	Brass with nickel plated
Seal/o-ring:	Silicone

Housing:	Brass with Cr plated
Insulation resistance:	≥ 100MΩ
IP rating:	IP 68
Shielding efficiency:	at 10MHz>95dB/at 1GHz>80dB
Salt spray corrosion test:	>144h

Size	Dimensions(mm)						
	A	e	E	L Max	M	S1	S2
0K	18	M14*1.0	6.0	20.1	4.0	12.5	17
1K	20	M16*1.0	9.0	25.1	4.5	14.5	19
2K	25	M20*1.0	9.0	28.6	5.0	18.5	24
3K	31	M24*1.0	11.0	33.6	6.0	22.5	30
4K	37	M30*1.0	11.0	37.2	7.0	28.5	36

Panel cut-out (page 180); PCB drilling pattern (page 185/186)

SRG Fixed Angled Socket, Key(G), Front Fasten

- Connector series: SRG
- Contact: Female
- Key: G(More keys, refer to page 072)
- Locking type: Self-locking
- Orientation type: Angled
- Part No.: SRG.XK.XXX.CLV
- Mated with: PSG series

Note: "X" refers to part number definition on page 051

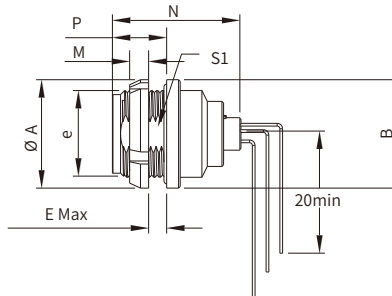

General Information

Ambient temperature:	-55°C~+200°C
Mating endurance:	>5000 cycles
Insulator:	PEEK
Connector contacts:	Brass with gold plated
Coupling nut/screw:	Brass with Cr plated
Housing:	Brass with Cr plated

Seal/o-ring	Silicone
Insulation resistance:	≥ 100MΩ
IP rating:	IP 68
Shielding efficiency:	at 10MHz>95dB / at 1GHz>80dB
Salt spray corrosion test:	>144h

Size	Dimensions(mm)							
	A	B	e	E	M	N	P	S1
0K	18	18	M14*1.0	3.4	3.5	19.3	7	12.5
1K	20	20	M16*1.0	6.2	3.5	24.3	10	14.5
2K	25	25	M20*1.0	5.0	3.5	26.6	10	18.5
3K	30	31	M24*1.0	7.5	4.5	31.3	12	22.5
4K	41.5	37	M30*1.0	6.0	7.0	34.2	13.5	28.5

Panel Cut-out page 180; PCB drilling pattern page 185/186; The dimension "N" depends on the number of contacts, detail information see page 185

SRG Fixed Straight Socket, Key(G), Front Fasten

- Connector series: SRG
- Contact: Female
- Key: G(More keys, refer to page 072)
- Locking type: Self-locking
- Orientation type: Straight
- Part No.: SRG.XK.XXX.CLL
- Mated with: PSG/PAG series

Note: "X" refers to part number definition on page 051

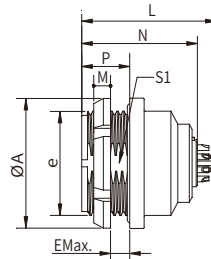

General Information

Ambient temperature:	-55°C~+200°C
Endurance:	>5000 cycles
Insulator:	PEEK
Connector contacts:	Brass with gold plated
Coupling nut/screw:	Brass with Cr plated
Seal/o-ring:	Silicone

Housing:	Brass with Cr plated
Insulation resistance:	≥ 100MΩ
IP rating:	IP 68
Shielding efficiency:	at 10MHz>95dB/at 1GHz>80dB
Salt spray corrosion test:	>144h

Size	Dimensions(mm)							
	A	e	E	L Max	M	N	P	S1
0K	18	M14*1.0	3.4	21.7	3.5	20.1	7	12.5
1K	20	M16*1.0	6.2	27.0	3.5	25.1	10	14.5
2K	25	M20*1.0	5.0	30.7	3.5	28.6	10	18.5
3K	30	M24*1.0	7.5	36.2	4.5	33.6	12	22.5
4K	41.5	M30*1.0	6.0	39.2	7.0	34.2	13.5	28.5

Note: Panel cut-out (page 180); The dimension "N" depends on the number of contacts, detail information see page 185

■ SRG Fixed Straight Socket, Key(G), Front Fasten, Contact for Printed Circuit

- Connector series: SRG
- Contact: Female
- Key: G(More keys, refer to page 072)
- Locking type: Self-locking
- Orientation type: Straight
- Part No.: SRG.XK.XXX.CLN
- Mated with: PSG/PAG series

Note: "X" refers to part number definition on page 051

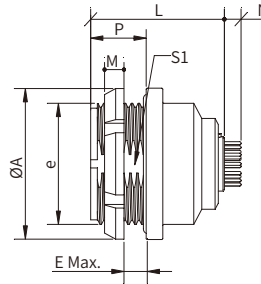

■ General Information



Ambient temperature:	-55°C~+200°C
Endurance:	>5000 cycles
Insulator:	PEEK
Connector contacts:	Brass with gold plated
Coupling nut/screw:	Brass with Cr plated
Seal/o-ring:	Silicone

Housing:	Brass with Cr plated
Insulation resistance:	≥100MΩ
IP rating:	IP 68
Shielding efficiency:	at 10MHz>95dB/at 1GHz>80dB
Salt spray corrosion test:	>144h

Size	Dimensions(mm)						
	A	e	E	L Max	M	P	S1
0K	18	M14*1.0	3.4	17.6	3.5	7	12.5
1K	20	M16*1.0	6.2	23.8	3.5	10	14.5
2K	25	M20*1.0	5.0	25.8	3.5	10	18.5
3K	30	M24*1.0	7.5	31.3	4.5	12	22.5

Panel cut-out (page 180); PCB drilling pattern (page 185/186)

■ SWG Fixed Socket, Nut Fixing, Key(G), Watertight

- Connector series: SWG
- Contact: Female
- Key: G(More keys, refer to page 072)
- Locking type: Self-locking
- Orientation type: Straight
- Part No.: SWG.XK.XXX.CLL
- Mated with: PSG/PAG

Note: "X" refers to part number definition on page 051

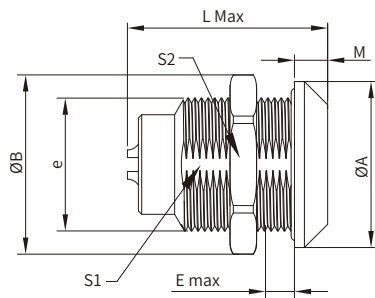

■ General Information



Ambient temperature:	-20°C ~ +80°C/100°C
Endurance:	>5000 cycles
Insulator:	PEEK
Connector contacts:	Brass with gold plated
Coupling nut/screw:	Brass with nickel plated

Housing:	Brass with Cr plated
Insulation resistance:	≥100MΩ
IP rating:	IP 68
Shielding efficiency:	at 10MHz>95dB/at 1GHz>80dB
Salt spray corrosion test:	>144h

Size	Dimensions(mm)							
	A	B	e	E	L	M	S1	S2
0K	18	19.2	M14x1.0	5.5	23.0	4.0	12.5	17
1K	20	21.5	M16*1.0	9.0	30.0	4.5	14.5	19
2K	25	27	M20*1.0	13.0	33.7	5.0	18.5	24
3K	31	34	M24*1.0	16.0	41.7	6.0	22.5	30

Panel Cut-out page 180

■ ASG Free Straight Socket, Key(G)

- Connector series: ASG
- Contact: Female
- Key: G(More keys, refer to page 072)
- Locking type: Self-locking
- Orientation type: Straight
- Part No.: ASG.XK.XXX.CLLCXXZ
- Mated with: PSG/PAG series

Note: "X" refers to part number definition on page 051

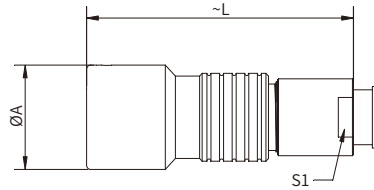

■ General Information



Ambient temperature:	-55°C~+200°C
Endurance:	>5000 cycles
Insulator:	PEEK
Connector contacts:	Brass with gold plated
Seal/o-ring:	Silicone

Housing:	Brass with Cr plated
Insulation resistance:	≥100MΩ
IP rating:	IP 68
Shielding efficiency:	at 10MHz>95dB/at 1GHz>80dB
Salt spray corrosion test:	>144h

Size	Dimensions(mm)		
	A	L	S1
0K	13	34	7
1K	15	45	9
2K	19	54	12
3K	23	64	15
4K	29	75	19

■ AFG Fixed Straight Socket, Nut Fixing, Key(G)

- Connector series: AFG
- Contact: Female
- Key: G(More keys, refer to page 072)
- Locking type: Self-locking
- Orientation type: Straight
- Part No.: AFG.XK.XXX.CLLCXX

Note: "X" refers to part number definition on page 051

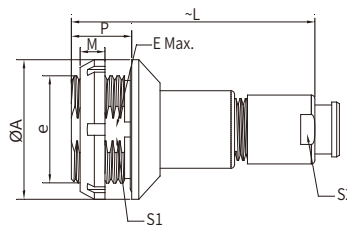

■ General Information



Ambient temperature:	-55°C~+200°C
Endurance:	>5000 cycles
Insulator:	PEEK
Connector contacts:	Brass with gold plated
Coupling nut/screw:	Brass with Cr plated
Seal/o-ring:	Silicone

Housing:	Brass with Cr plated
Insulation resistance:	≥100MΩ
IP rating:	IP 68
Shielding efficiency:	at 10MHz>95dB/at 1GHz>80dB
Salt spray corrosion test:	>144h

Size	Dimensions(mm)							
	A	e	E	L	M	P	S1	S2
0K	18	M14*1.0	5.0	34	3.5	8.5	12.5	8
1K	20	M16*1.0	6.5	45	3.5	10.0	14.5	9
2K	25	M20*1.0	4.0	54	3.5	7.5	18.5	12
3K	30	M24*1.0	7.5	65	4.5	12.0	22.5	15

Panel cut-out (page 180)

■ PYG Fixed Plug With Round Flange, Key(G) Or Keys(a To F, L And R), With Cable Collet

- Connector series: PYG
- Contact: Male
- Key: G(More keys, refer to page 072)
- Locking type: Self-locking
- Orientation type: Straight
- Part No.: PYG.xK.3xx.xLACxx
- Mated with: FSG/SRG/ASG/SWG/AFG

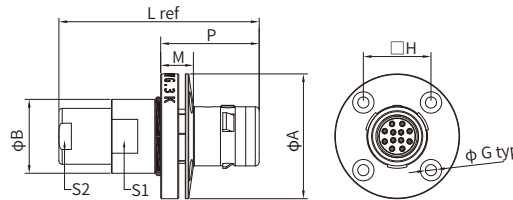

Note: "X" refers to part number definition on page 051

■ General Information

Ambient temperature:	-55°C ~ + 200°C
Endurance:	>5000 cycles
Insulator:	PEEK
Connector contacts:	Brass with gold plated
Housing:	Brass with Cr plated

O-Ring:	Silicone
Insulator resistance:	≥100MΩ
IP rating:	IP 68
Shielding efficiency:	at 10MHz>95dB/at 1GHz>80dB
Salt spray corrosion test:	>144h

Size	Dimensions(mm)								
	A	B	G	H	L	M	P	S1	S2
3K	38	22.5	3.4	20.6	61	10.0	30.0	15	20
4K	47	28.5	3.4	27.0	71	11.0	32.0	19	25

■ FMG Fixed Socket With Square Flange, Key(G), Screw Fixing

- Connector series: FMG
- Contact: Female
- Key: G(More keys, refer to page 072)
- Locking type: Screw locking
- Orientation type: Straight
- Part No.: FMG.3K.3xx.xLL
- Mated with: PMG

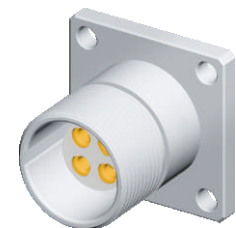
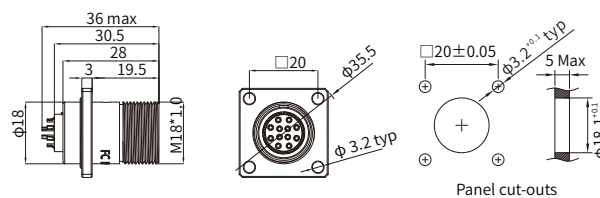

Note: "X" refers to part number definition on page 051

■ General Information

Ambient temperature:	-55°C ~ + 200°C
Endurance:	>3000 cycles
Insulator:	PEEK
Connector contacts:	Brass with gold plated
Housing:	Brass with Cr plated

O-Ring:	Silicone
Insulator resistance:	≥100MΩ
IP rating:	IP 68
Shielding efficiency:	at 10MHz>95dB/at 1GHz>80dB
Salt spray corrosion test:	>144h

■ PMG Straight Plug, Key (G) , Nut For Bend Relief, Screw Locking and Cable Collet

- Connector series: PMG
- Contact: Male
- Key: G(More keys, refer to page 072)
- Locking type: Screw locking
- Orientation type: Straight
- Part No.: PMG.xK.3xx.CLAC(Z)
- Mated with: FMG.XK.3XX.CLL

Note: "X" refers to part number definition on page 051

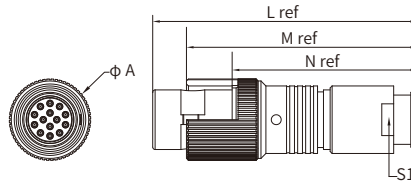

■ General Information

Ambient temperature:	-55°C ~ + 200°C
Endurance:	>3000 cycles
Insulator:	PEEK
Connector contacts:	Brass with gold plated
Housing:	Brass with Cr plated

Gasket:	Silicone
Insulator resistance:	≥100MΩ
IP rating:	IP 68
Shielding efficiency:	at 10MHz>95dB/at 1GHz>80dB
Salt spray corrosion test:	>144h

Size	Dimensions(mm)				
	A	L	M	N	S1
2K	20.5	66.7	58.2	46.7	15
3K	20.5	59.7	51.2	44.2	12

■ FJG Fixed Socket With Square Flange, Key (G) or (a To F, L And R), Protruding Shell And Earthing Tag

- Connector series: FJG
- Contact: Female
- Key: G(More keys, refer to page 072)
- Locking type: Self-locking
- Orientation type: Straight
- Part No.: FJG.3K.3xx.xLL
- Mated with: PSG

Note: "X" refers to part number definition on page 051

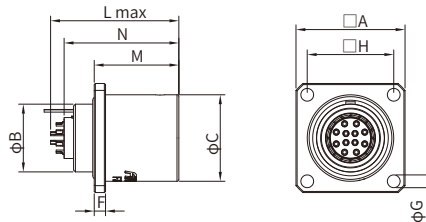

■ General Information

Ambient temperature:	-55°C ~ + 200°C
Endurance:	>5000 cycles
Insulator:	PEEK
Connector contacts:	Brass with gold plated
Housing:	Brass with Cr plated

Gasket:	Silicone
Insulator resistance:	≥100MΩ
IP rating:	IP 68
Shielding efficiency:	at 10MHz>95dB/at 1GHz>80dB
Salt spray corrosion test:	>144h

Size	Dimensions(mm)								
	A	B	C	F	G	H	L	M	N ¹⁾
3K	29	18	23	3	3.4	23	36.2	22.5	32.6

Note: 1) maximum length with crimp contacts Panel cut-out (page 180)

■ AMG Angled Plug, Key(G), Nut for Bend Relief, Screw Locking, Cable Collet

- Connector series: AMG
- Contact: Male
- Key: G(More keys, refer to page 072)
- Locking type: Screw Locking
- Orientation type: Angled
- Part No.: AMG.2K.3XX.CLACXXZ
- Mated with: FMG

Note: "X" refers to part number definition on page 051

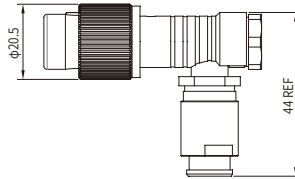

■ General Information

Ambient temperature:	-55°C ~ + 200°C
Endurance:	>3000 cycles
Insulator:	PEEK
Connector contacts:	Brass with gold plated
Coupling nut/screw:	Brass with Cr plated

Housing:	Brass with Cr plated
Insulator resistance:	≥100MΩ
IP rating:	IP 68
Shielding efficiency:	at 10MHz>75dB/at 1GHz>40dB
Salt spray corrosion test:	>144h

■ EDW Straight Socket, Key(G), Quick Locking

- Connector series: EDW
- Contact: Female
- Key: G(More keys, refer to page 072)
- Locking type: Screw Locking
- Orientation type: Straight
- Part No.: EDW.2K.3XX.CLL
- Mated with: PSG.2K

Note: "X" refers to part number definition on page 051

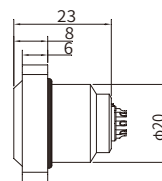
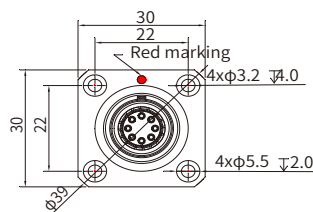

■ General Information

Ambient temperature:	-55°C ~ + 200°C
Endurance:	>3000 cycles
Insulator:	PEEK
Connector contacts:	Brass with gold plated
Out shell:	Brass with Cr plated

Insulator resistance:	≥100MΩ
IP rating:	IP 68
Shielding efficiency:	at 10MHz>75dB/at 1GHz>40dB
Salt spray corrosion test:	>144h

■ FMG Straight Socket, Key(G), Screw Locking

- Connector series: FMG
- Contact: Female
- Key: G(More keys, refer to page 072)
- Locking type: Screw Locking
- Orientation type: Straight
- Part No.: FMG.2K.3XX.CLL
- Mated with: PMG

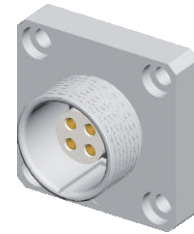
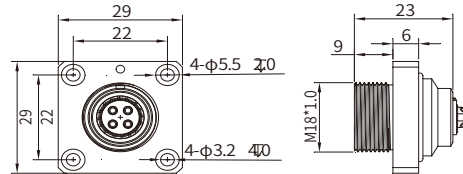

Note: "X" refers to part number definition on page 051

■ General Information

Ambient temperature:	-55°C ~ + 200°C
Endurance:	>3000 cycles
Insulator:	PEEK
Connector contacts:	Brass with gold plated
Out shell:	Brass with Cr plated

Insulator resistance:	≥100MΩ
IP rating:	IP 68
Shielding efficiency:	at 10MHz>75dB/at 1GHz>40dB
Salt spray corrosion test:	>144h

■ PMG Straight Plug, Key(G), Nut for Bend Relif, Screw Locking, Cable Collet

- Connector series: PMG
- Contact: Male
- Key: G(More keys, refer to page 072)
- Locking type: Screw locking
- Orientation type: Straight
- Part No.: PMG.2K.3XX.CLADXXZ
- Mated with: FMG

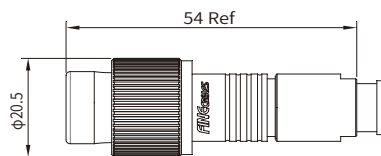

Note: "X" refers to part number definition on page 051

■ General Information

Ambient temperature:	-55°C ~ + 200°C
Endurance:	>3000 cycles
Insulator:	PEEK
Connector contacts:	Brass with gold plated
Coupling nut/screw:	Brass with Cr plated

Housing:	Brass with Cr plated
Insulator resistance:	≥100MΩ
IP rating:	IP 68
Shielding efficiency:	at 10MHz>75dB/at 1GHz>40dB
Salt spray corrosion test:	>144h

■ PSG Straight Plug, Key(G), Optical Fiber Type

- Connector series: PSG.2K.93C
- Contact: Male
- Key: G(More keys, refer to page 072)
- Locking type: Self-locking
- Orientation type: Straight
- Part No.: PSG.2K.93C
- Mated with: FSG.2K.93C

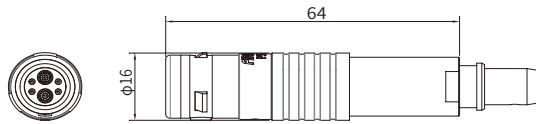

■ General Information

Ambient temperature:	-55°C ~ + 90°C
Endurance:	>5000 cycles
Insulator:	PEEK
Connector contacts:	Brass with gold plated/ceramic
Coupling nut/screw:	Brass with Cr plated
Housing:	Brass with Cr plated

Insulator resistance:	≥100MΩ
IP rating:	IP 68
Shielding efficiency:	at 10MHz>75dB/at 1GHz>40dB
Salt spray corrosion test:	>144h
Average insertion loss fibre 1.25mm/upc:	<0.25dB
Return loss fibre 1.25mm/upc:	>45dB

■ FSG Straight Socket, Key(G), Optical Fiber Type

- Connector series: FSG.2K.93C
- Contact: Female
- Key: G(More keys, refer to page 072)
- Locking type: Self-locking
- Orientation type: Straight
- Part No.: FSG.2K.93C.CLL
- Mated with: PSG.2K.93C

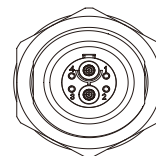
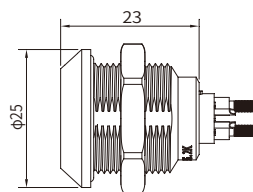

■ General Information

Ambient temperature:	-55°C ~ + 90°C
Endurance:	>5000 cycles
Insulator:	PEEK
Connector contacts:	Brass with gold plated
Coupling nut/screw:	Brass with nickel plated
Housing:	Brass with Cr plated

Insulator resistance:	≥100MΩ
IP rating:	IP 68
Shielding efficiency:	at 10MHz>75dB/at 1GHz>40dB
Salt spray corrosion test:	>144h
Average insertion loss fibre 1.25mm/upc:	<0.25dB
Return loss fibre 1.25mm/upc:	>45dB

■ MSG Fixed Plug, Nut Fixing, Key(G)

- Connector series: MSG
- Contact: Male
- Locking type: Self-locking
- Orientation type: Straight
- Part No.: MSG.1K.XXX.CLA
- Mated with: FSG/SRG series

Note: "X" refers to part number definition on page 051

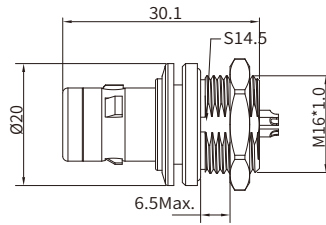

■ General Information

Ambient temperature:	-55°C ~ + 200°C
Endurance:	>5000 cycles
Insulator:	PEEK
Connector contacts:	Brass with gold plated
Coupling nut/screw:	Brass with nickel plated
Seal/O-ring:	Silicone

Housing:	Brass with Cr plated
Insulator resistance:	≥100MΩ
IP rating:	IP 68
Shielding efficiency:	at 10MHz>95dB/at 1GHz>80dB
Salt spray corrosion test:	>144h

■ FSG Straight Socket, Key(G), Coaxial + Low Voltage Mixed

- Connector series: FSG
- Contact: Female
- Key: G(More keys, refer to page 072)
- Locking type: Self-locking
- Orientation type: Straight
- Part No.: FSG.4K.864.CLL
- Mated with: PSG

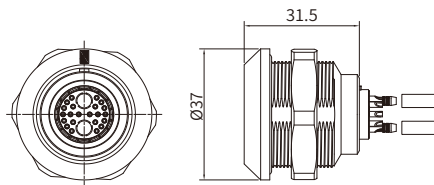

■ General Information

Ambient temperature:	-55°C ~ + 250°C
Endurance:	>5000 cycles
Insulator:	PEEK
Connector contacts:	Brass with gold plated
Out shell:	Brass with Cr plated

Insulator resistance:	≥100MΩ
IP rating:	IP 68
Shielding efficiency:	at 10MHz>75dB/at 1GHz>40dB
Salt spray corrosion test:	>144h

■ PSG Straight Plug, Key(G), Coaxial + Low Voltage Mixed

- Connector series: PSG
- Contact: Male
- Key: G(More keys, refer to page 072)
- Locking type: Self-locking
- Orientation type: Straight
- Part No.: PSG.4K.864.CLACXXZ
- Mated with: FSG.4K.864

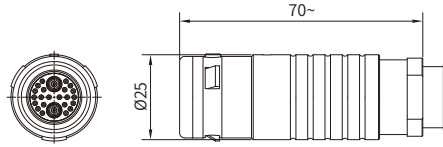

Note: "X" refers to part number definition on page 051

■ General Information

Ambient temperature:	-55°C ~ + 250°C
Endurance:	>5000 cycles
Insulator:	PEEK
Connector contacts:	Brass with gold plated
Coupling nut/screw:	Brass with Cr plated

Housing:	Brass with Cr plated
Insulator resistance:	≥100MΩ
IP rating:	IP 68
Shielding efficiency:	at 10MHz>75dB/at 1GHz>40dB
Salt spray corrosion test:	>144h

■ PRG Fixed Straight Socket, Key(G), Cable Collet

- Connector series: PRG
- Contact: Female
- Key: G(More keys, refer to page 072)
- Locking type: Self-locking
- Orientation type: Straight (lanyard release)
- Part No.: PRG.XK.XXX.CLLCXX
- Mated with: PSG/PAG series

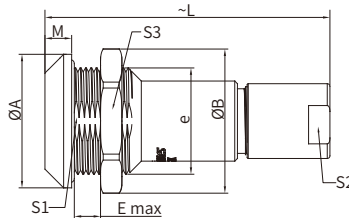

Note: "X" refers to part number definition on page 051

■ General Information



Ambient temperature:	-55 °C ~ + 200 °C
Endurance:	>5000 cycles
Insulator:	PEEK
Connector contacts:	Brass with gold plated
Coupling nut/screw:	Brass with nickel plated

Housing:	Brass with Cr plated
Insulator resistance:	≥100MΩ
IP rating:	IP 68
Shielding efficiency:	at 10MHz>95dB/at 1GHz>80dB
Salt spray corrosion test:	>144h

Size	Dimensions(mm)								
	A	B	e	E	L	M	S1	S2	S3
0K	18	19.2	M14*1.0	6	34	4	12.5	8	17
1K	20	21.5	M16*1.0	9	45	4.5	14.5	9	19
2K	25	27	M20*1.0	9	54	5	18.5	12	24
3K	31	34	M24*1.0	11.5	65	6	22.5	15	30

Panel cut-out (page 180)

■ CHG Plug Caps, Nut Fixing Or Flange

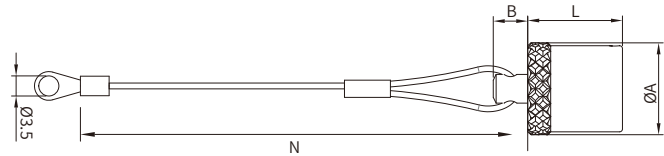

■ General Information

Ambient temperature:	Maximum 135°C
Endurance:	>5000 cycles
Body material	Nickel-plated brass
Lanyard materiel	Staninless steel

Crimp ferrule material:	Nickel-plated brass+polyolefin
O-ring material	Silicone rubber or FPM
IP rating:	IP 68
Salt spray corrosion test:	>144h

Part number	Size	Dimensions(mm)			
		A	B	L	N
CHG.0K.100.NAS	0K	14.0	6	12.5	85
CHG.1K.100.NAS	1K	16.0	6	15.5	85
CHG.2K.100.NAS	2K	19.5	6	17.5	85
CHG.3K.100.NAS	3K	23.0	6	22.0	120
CHG.4K.100.NAS	4K	29.0	10	22.5	250

Note: This cap is available only with an alignment key (G). The last letter "S" of part number stands for the material of the O-ring (silicone rubber). O-ring's made from FPM are also available; if required, replace the letter "S" by "V"

■ CRE Blanking Caps For Fixed Sockets

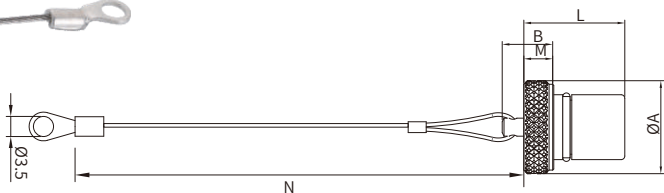

■ General Information

Ambient temperature:	Maximum 135°C
Endurance:	>5000 cycles
Body material	Nickel-plated brass
Lanyard materiel	Staninless steel

Crimp ferrule material:	Nickel-plated brass+polyolefin
O-ring material	Silicone rubber or FPM
IP rating:	IP 68
Salt spray corrosion test:	>144h

Part number	Size	Dimensions(mm)				
		A	B	L	M	N
CRE.0K.200.NAS	0K	15.0	10	15.0	4	85
CRE.1K.200.NAS	1K	17.0	12	20.0	6	85
CRE.2K.200.NAS	2K	20.5	14	24.0	8	85
CRE.3K.200.NAS	3K	24.0	14	28.0	8	120
CRE.4K.200.NAS	4K	30.0	20.5	30.5	10	250

Note: This caps are suitable for use with any alignment key configuration. The last letter "S" of part number stands for the material of the O-ring (silicone rubber). O-ring's made from FPM are also available; if required, replace the letter "S" by "V"

■ CFA Plug Caps, Sliding Loop

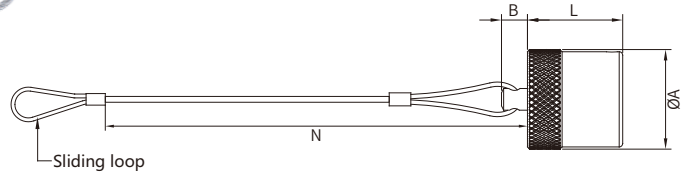

■ General Information

Ambient temperature:	maximum 135 °C
Endurance:	>5000 cycles
Body material:	Brass with nickel plated
Lanyard material:	Stainless steel

Crimp ferrule material:	Brass with nickel plated
O-ring material:	Silicone or FPM
Ip rating:	IP68
Salt spray corrosion test:	>144h

Part number	Size	Dimensions(mm)			
		A	B	L	N
CFA.0K.100.NAS	0K	14.0	6	12.5	85
CFA.1K.100.NAS	1K	16.0	6	15.5	85
CFA.2K.100.NAS	2K	19.5	6	17.5	85
CFA.3K.100.NAS	3K	23.0	6	22.0	150
CFA.4K.100.NAS	4K	29.0	10	22.5	250

Note: This cap is available only with an alignment key (G). The last letter "S" of part number stands for the material of the O-ring (silicone rubber). O-ring's made from FPM are also available; if required, replace the letter "S" by "V"

■ CRF Blanking Caps For Fixed Sockets, Sliding Loop

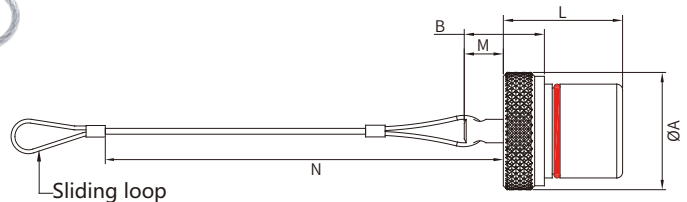

■ General Information

Ambient temperature:	maximum 135 °C
Endurance:	>5000 cycles
Body material:	Brass with nickel plated
Lanyard material:	Stainless steel

Crimp ferrule material:	Brass with nickel plated
O-ring material:	Silicone or FPM
Ip rating:	IP68
Salt spray corrosion test:	>144h

Part number	Size	Dimensions(mm)				
		A	B	L	M	N
CRF.0K.200.NAS	0K	15.0	10	15.0	4	85
CRF.1K.200.NAS	1K	17.0	12	20.0	6	85
CRF.2K.200.NAS	2K	20.5	14	24.0	8	85
CRF.3K.200.NAS	3K	24.0	14	28.0	8	150
CRF.4K.200.NAS	4K	30.0	20.5	30.5	10	250

Note: This cap is available only with an alignment key (G). The last letter "S" of part number stands for the material of the O-ring (silicone rubber). O-ring's made from FPM are also available; if required, replace the letter "S" by "V"

■ CRR Spring Loaded Dust Cap For 3k Series FSG And Swg Fixed Sockets

- Series: CRR
- Part No.: CRR.3K.200.NZS

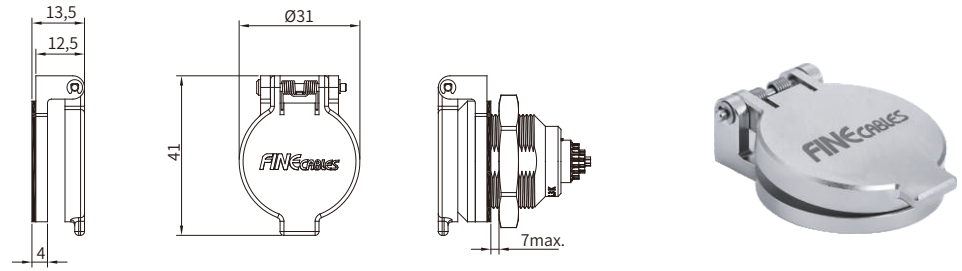

■ General Information

Ambient temperature:	-55°C ~ + 200 °C
Endurance:	>5000 cycles
Body material:	Brass with nickel plated
Gasket material:	Silicone
Spring material:	Stainless steel

Clip material:	Stainless steel
Axes material:	Stainless steel
IP rating:	IP 61
Salt spray corrosion test:	>144h

■ Electrical & Mechanical Data

PS · G · OK · 305 · C L A C 45

Insert configuration

Size	Part.No	Pin Count	Pin layout From the direction of solder		Contact Dim (mm)	Rated current (A)	Contact type			Test voltage(KV rms)			
			Male	Female			Solder	Print	Crimp	Solder contact		Crimp contact	
										Contact and Contact	Contact and Shell	Contact and Contact	Contact and Shell
OK	302	02			0.9	10.0	●	●	●	1.00	1.05	1.45	1.20
	303	03			0.9	8.0	●	●	●	1.20	0.90	1.70	1.60
	304	04			0.7	7.0	●	●	●	0.85	0.70	1.35	1.10
	305	05			0.7	6.5	●	●	●	1.00	0.70	1.25	1.20
	306	06			0.5	2.5	●	●	○	0.85	0.65	1.40	1.20
	307	07			0.5	2.5	●	●	○	0.80	0.70	1.40	1.20
	309	09			0.5	2.0	●	●	○	0.60	0.50	1.00	0.85
	312	12			0.35	1.5	●	●	-	0.80	1.00	-	-

It is proposed according to the following ratio : Operating Voltage (Us) = Test voltage(Ue) / 3

● First Recommendation ○ Special order alternative

Caution:

For a number of applications, safety requirements for electrical appliances are more severe with regard to operating voltage.

In such cases operating voltage is defined according to creepage distance and air clearance) between live parts.

Electrical & Mechanical Data

PS · G · 0K · 305 · C L A C 45

Insert configuration

Size	Part.No	Pin Count	Pin layout From the direction of solder		Contact Dim (mm)	Rated current (A)	Contact type			Test voltage(KV rms)			
			Male	Female			Solder	Print	Crimp	Solder contact		Crimp contact	
										Contact and Contact	Contact and Shell	Contact and Contact	Contact and Shell
1K	302	02			1.3	15.0	●	●	●	1.50	1.35	1.70	1.45
	303	03			1.3	12.0	●	●	●	1.30	1.55	1.60	1.85
	304	04			0.9	10.0	●	●	●	1.35	1.45	1.70	1.80
	305	05			0.9	9.0	●	●	●	1.25	1.15	1.30	1.55
	306	06			0.7	7.0	●	●	●	1.05	1.20	1.35	1.45
	307	07			0.7	7.0	●	●	●	0.95	1.05	1.45	1.45
	308	08			0.7	5.0	●	●	●	0.95	1.15	1.30	1.30
	310	10			0.5	2.5	●	●	○	0.90	1.50	1.20	1.80
	314	14			0.5	2.0	●	●	○	0.80	1.20	0.95	1.60
	316	16			0.5	1.5	●	●	○	0.80	1.25	0.95	1.60

It is proposed according to the following ratio : Operating Voltage (Us) = Test voltage(Ue) / 3

● First Recommendation ○ Special order alternative

Caution:

For a number of applications, safety requirements for electrical appliances are more severe with regard to operating voltage.

In such cases operating voltage is defined according to creepage distance and air clearance) between live parts.

■ Electrical & Mechanical Data

Size	Part.No	Pin Count	Pin layout From the direction of solder		Contact Dim (mm)	Rated current (A)	Contact type			Test voltage(KV rms)			
			Male	Female			Solder	Print	Crimp	Solder contact		Crimp contact	
										Contact and Contact	Contact and Shell	Contact and Contact	Contact and Shell
2K	302	02			2.0	30.0	●	○	○	2.10	1.75	2.85	2.70
	303	03			1.6	17.0	●	○	○	2.40	1.85	1.90	1.90
	304	04			1.3	15.0	●	●	●	1.85	1.85	2.20	2.20
	305	05			1.3	14.0	●	●	●	1.75	1.60	2.15	2.15
	306	06			1.3	12.0	●	●	●	1.35	1.45	2.00	2.35
	307	07			1.3	11.0	●	●	●	1.75	1.60	1.95	2.15
	308	08			0.9	10.0	●	●	●	1.50	1.25	1.95	1.95
	310	10			0.9	8.0	●	●	●	1.45	1.30	1.80	2.10
	312	12			0.7	7.0	●	●	●	1.25	1.35	1.65	2.00
	314	14			0.7	6.5	●	●	●	1.15	1.35	1.55	1.95
	316	16			0.7	6.0	●	●	●	0.95	1.25	1.55	1.75
	318	18			0.7	5.5	●	●	●	0.85	1.20	1.45	2.10
	319	19			0.7	5.0	●	●	●	0.95	1.25	1.55	1.65
	326	26			0.5	2.0	●	●	—	0.95	1.30	1.20	1.80
	332	32			0.5	1.5	●	●	—	0.80	1.20	0.95	1.60

It is proposed according to the following ratio : Operating Voltage (Us) = Test voltage(Ue) / 3 ● First Recommendation ○ Special order alternative

Caution:

For a number of applications, safety requirements for electrical appliances are more severe with regard to operating voltage.

In such cases operating voltage is defined according to creepage distance and air clearance) between live parts.

■ Electrical & Mechanical Data

Size	Part.No	Pin Count	Pin layout From the direction of solder		Contact Dim (mm)	Rated current (A)	Contact type			Test voltage(KV rms)			
			Male	Female			Solder	Print	Crimp	Solder contact		Crimp contact	
										Contact and Contact	Contact and Shell	Contact and Contact	Contact and Shell
3K	302	02			3.0	35.0	●	○	●	2.10	1.55	2.30	1.80
	303	03			2.0	25.0	●	●	●	1.90	1.50	3.20	2.65
	304	04			2.0	19.0	●	●	●	1.45	1.25	2.50	2.20
	305	05			1.6	19.0	●	●	●	1.90	1.25	2.40	1.75
	306	06			1.6	17.0	●	●	●	1.60	1.15	1.90	1.80
	307	07			1.6	15.0	●	●	●	1.70	1.25	2.00	2.05
	308	08			1.3	13.0	●	●	●	1.65	1.15	1.85	1.75
	514 (Cat 6A insulator)	08			0.7	10	○	○	●	-	-	1.5	1.5
	309	09			8x1.3 1x2.0	6.0 15.0	●	●	●	1.35 1.35	1.05 1.05	1.10 1.10	1.05 1.05
	310	10			1.3	12.0	●	●	●	1.25	0.90	1.50	1.80
	312	12			0.9	9.0	●	●	●	1.45	1.00	1.65	1.85
	314	14			0.9	9.0	●	●	●	1.20	1.20	1.80	1.65
	316	16			0.9	8.0	●	●	●	1.20	0.85	1.80	1.50
	318	18			0.9	7.0	●	●	●	1.20	1.05	1.85	1.60
	320	20			0.7	6.0	●	●	●	1.00	0.90	1.35	1.55
	322	22			0.7	5.5	●	●	●	1.00	0.90	1.70	1.45
	324	24			0.7	4.0	●	●	●	0.95	0.80	1.35	1.35
	326	26			0.7	4.0	●	●	●	0.95	0.70	1.50	1.30
	330	30			0.7	3.5	●	●	●	0.80	0.70	1.35	1.20

It is proposed according to the following ratio : Operating Voltage (Us) = Test voltage(Ue) / 3

● First Recommendation ○ Special order alternative

Caution:

For a number of applications, safety requirements for electrical appliances are more severe with regard to operating voltage.

In such cases operating voltage is defined according to creepage distance and air clearance) between live parts.

■ Electrical & Mechanical Data

Size	Part.No	Pin Count	Pin layout From the direction of solder		Contact Dim (mm)	Rated current (A)	Contact type			Test voltage(KV rms)			
			Male	Female			Solder	Print	Crimp	Solder contact		Crimp contact	
										Contact and Contact	Contact and Shell	Contact and Contact	Contact and Shell
4K	304	04			3.0	30.0	●	○	●	2.10	1.50	1.80	1.20
	306	06			2.0	24.0	●	○	●	2.00	1.75	2.75	2.40
	307	07			2.0	20.0	●	○	●	2.00	1.80	1.50	1.35
	310	10			1.6	17.0	●	○	●	1.85	1.30	1.90	1.95
	312	12			1.3	12.0	●	○	●	1.45	1.60	1.90	1.85
	316	16			0.9	10.0	●	●	●	1.35	1.50	2.30	2.10
	320	20			0.9	8.0	●	●	●	1.35	1.00	1.05	0.95
	324	24			0.9	7.0	●	●	●	1.20	1.45	1.80	2.05
	330	30			0.9	5.0	●	●	●	0.95	0.85	1.75	1.45
	340	40			0.7	2.0	●	●	●	0.90	0.90	1.30	1.30
	348	48			0.7	1.5	●	●	●	0.70	0.70	1.00	1.00

It is proposed according to the following ratio : Operating Voltage (Us) = Test voltage(Ue) / 3 ● First Recommendation ○ Special order alternative

Caution:

For a number of applications, safety requirements for electrical appliances are more severe with regard to operating voltage. In such cases operating voltage is defined according to creepage distance and air clearance) between live parts.

Alignment Key, Metal Material & Plate

PS · G · OK · 305 · C L A C 45

Alignment key:

Code	No. of keys	Series						Contact type		Notes
		Angles	0K	1K	2K	3K	Plug	Socket		
G	1	-	0°	0°	0°	0°	male	female	●	
A	2	AG1	30°	30°	30°	30°	male	female	●	
B	2		45°	45°	45°	45°	male	female	●	
C	2		60°	60°	60°	60°	male	female	●	
D	2	AG3	95°	95°	95°	95°	male	female	○	
E	2	AG2	120°	120°	120°	120°	male	female	○	
F	2		145°	145°	145°	145°	male	female	○	
L	2	AG3	75°	75°	75°	75°	female	male	●	

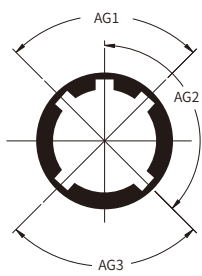

Metal material&plate:

Reference	Out shell+collet nut		Latch sleeve+earth crown		Other metallic components		Remarks	Notes
	Material	Surftreatment	Material	Surftreatment	Material	Surftreatment		
C	Brass	Chrome	Brass-bronze	Nickel	Brass	Nickel		●
N	Brass	Nickel	Brass-bronze	Nickel	Brass	Nickel		○
K	Brass	Black Chrome	Brass-bronze	Nickel	Brass	Nickel		●
S	Stainless steel	-	Brass-bronze	Nickel	Brass	Nickel		●
P	PSU	-	Brass-bronze	Nickel	Brass	Nickel	Available for some parts of B series	●
H	PPS/Brass	-/Nickel	Brass-bronze	Nickel	Brass	Nickel	Only for elbow sockets (B series)	●

● First Recommendation ○ Special order alternative

■ Insulator & Contact Type

PS · G · 0K · 305 · C L A C 45

Insulator&contact type

	Y	L
Insulator material	PEEK	PEEK
Contact type	Crimp	Solder or print

Contacts reference for plugs free or fixed sockets

Contact type	Reference		Contact (mm)		Conductor Size					
					Solid		Stranded			
	Male	Female	Pin OD	Wire OD	AWG max.	Section max. (mm ²)	AWG		Section (mm ²)	
						min.	max.	min.	max.	
Solder	A	L	0.5	0.4	28	0.09		30		0.05
			0.5	0.45	28	0.09		28		0.09
			0.7	0.8	22	0.34		22		0.34
			0.9	0.8	22	0.34		22		0.34
			1.3	1.0	20	0.50		20		0.50
			1.6	1.4	16	1.00		18		1.00
			2.0	1.8	14	1.50		16		1.50
			3.0	2.7	10	4.00		12		4.00
Crimp	C	M	0.5	0.45			32	28	0.035	0.09
	C	M	0.7	0.80			26	22	0.140	0.34
	B	P	0.7	0.45			32	28	0.035	0.09
	C	M	0.9	1.10			24	20	0.250	0.50
	B	P	0.9	0.80			26	22	0.140	0.34
	G	U	0.9	0.45			32	28	0.035	0.09
	C	M	1.3	1.40			20	18	0.500	1.00
	B	P	1.3	1.10			24	20	0.250	0.50
	G	U	1.3	0.80			26	22	0.140	0.34
	C	M	1.6	1.90			18	14	1.000	1.50
	B	P	1.6	1.40			22	18	0.340	1.00
	C	M	2.0	2.40			16	12	1.500	2.50
	B	P	2.0	1.90			18	14	1.000	1.50
C	M	3.0	2.90			14	10	2.500	4.00	
Print	D	N								
Print Angled	W	V								

Collet Type

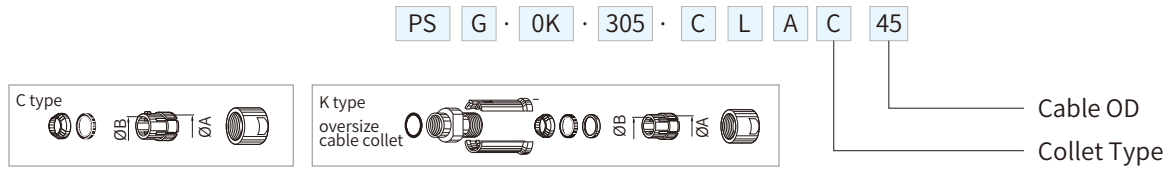

Series	Reference		Collet OD		Cable OD	
	Type	Code	A	B	max.	min.
0K	C	10	1.6	-	1.2	1.0
	C	15	1.6	-	1.5	1.3
	C	20	2.1	-	2.0	1.6
	C	25	3.1	-	2.5	2.1
	C	30	3.1	-	3.0	2.6
	C	35	4.2	4.2	3.5	3.1
	C	40	4.2	4.2	4.0	3.6
	C	45	5.2	5.2	4.5	4.1
	C	50	5.2	5.2	5.0	4.6
1K	C	15	1.6	-	1.5	1.3
	C	20	2.2	-	2.0	1.6
	C	25	3.2	-	2.5	2.1
	C	30	3.2	-	3.0	2.6
	C	35	4.2	-	3.5	3.1
	C	40	4.2	-	4.0	3.6
	C	45	5.2	-	4.5	4.1
	C	50	5.2	-	5.0	4.6
	C	55	6.2	6.2	5.5	5.1
	C	60	6.2	6.2	6.0	5.6
	C	65	7.2	6.7	6.5	6.1
	K	70	7.2	-	7.0	6.6
	K	75	8.2	8.2	7.5	7.1
	K	80	8.2	8.2	8.0	7.6
K	85	9.2	8.6	8.5	8.1	
2K	C	15	2.2	-	1.5	1.3
	C	20	2.2	-	2.0	1.6
	C	25	3.2	-	2.5	2.1
	C	30	3.2	-	3.0	2.6
	C	35	4.2	-	3.5	3.1
	C	40	4.2	-	4.0	3.6
	C	45	5.2	-	4.5	4.1
	C	50	5.2	-	5.0	4.6
	C	55	6.2	-	5.5	5.1
	C	60	6.2	-	6.0	5.6
	C	65	7.2	-	6.5	6.1
	C	70	7.2	-	7.0	6.6
	C	75	8.2	8.2	7.5	7.1
	C	80	8.2	8.2	8.0	7.6
	C	85	9.2	8.6	8.5	8.1
	K	90	9.2	-	9.0	8.6
	K	95	10.2	10.2	9.5	9.1
	K	10	10.2	10.2	10.0	9.6
	K	11	11.2	10.6	10.5	10.1

Note: All dimensions are in millimetres.

Series	Reference		Collet OD		Cable OD	
	Type	Code	A	B	max.	min.
3K	C	30	3.2	-	3.0	2.6
	C	35	4.2	-	3.5	3.1
	C	40	4.2	-	4.0	3.6
	C	45	5.2	-	4.5	4.1
	C	50	5.2	-	5.0	4.6
	C	55	6.2	-	5.5	5.1
	C	60	6.2	-	6.0	5.6
	C	65	7.2	-	6.5	6.1
	C	70	7.2	-	7.0	6.6
	C	75	8.2	-	7.5	7.1
	C	80	8.2	-	8.0	7.6
	C	85	9.2	-	8.5	8.1
	C	90	9.2	-	9.0	8.6
	C	95	10.2	10.2	9.5	9.1
	C	10	10.2	10.2	10.0	9.6
4K	K	11	11.2	10.6	10.5	10.1
	K	11	12.3	-	12.0	10.6
	K	12	13.8	13.8	12.8	12.1
	K	13	13.8	13.8	13.5	12.9
	K	14	15.3	15.3	14.0	13.6
	K	15	15.3	15.3	15.0	14.1
	C	50	6.3	-	5.0	4.6
	C	55	6.3	-	5.5	5.1
	C	60	6.3	-	6.0	5.6
	C	65	7.3	-	6.5	6.1
	C	70	7.3	-	7.0	6.6
	C	75	8.3	-	7.5	7.1
	C	80	8.3	-	8.0	7.6
	C	85	9.3	-	8.5	8.1
	C	90	9.3	-	9.0	8.6
C	95	10.8	-	9.5	9.1	
C	10	10.8	-	10.5	9.6	
C	11	12.3	-	12.0	10.6	
C	12	13.8	13.8	12.8	12.1	
C	13	13.8	13.8	13.5	12.9	
C	14	15.3	15.3	14.0	13.6	
C	15	15.3	15.3	15.0	14.1	
K	16	17.8	-	16.5	15.6	
K	17	17.8	-	17.5	16.6	
K	18	19.8	-	18.5	17.6	
K	19	19.8	-	19.5	18.6	
K	20	21.8	-	20.5	19.6	
K	21	21.8	-	21.5	20.6	
K	22	23.8	23.8	22.5	21.6	
K	23	23.8	23.8	23.5	22.6	

T Series

Key Features:

- Push-Pull self-latching system
- High packing density for space savings
- 360° shielding for full EMC shielding
- Compatible with existing B sockets
- Same mounting hole as B sockets
- Multipole types 2 to 9 contacts
- Solder, crimp or contacts



■ Part Number Definition

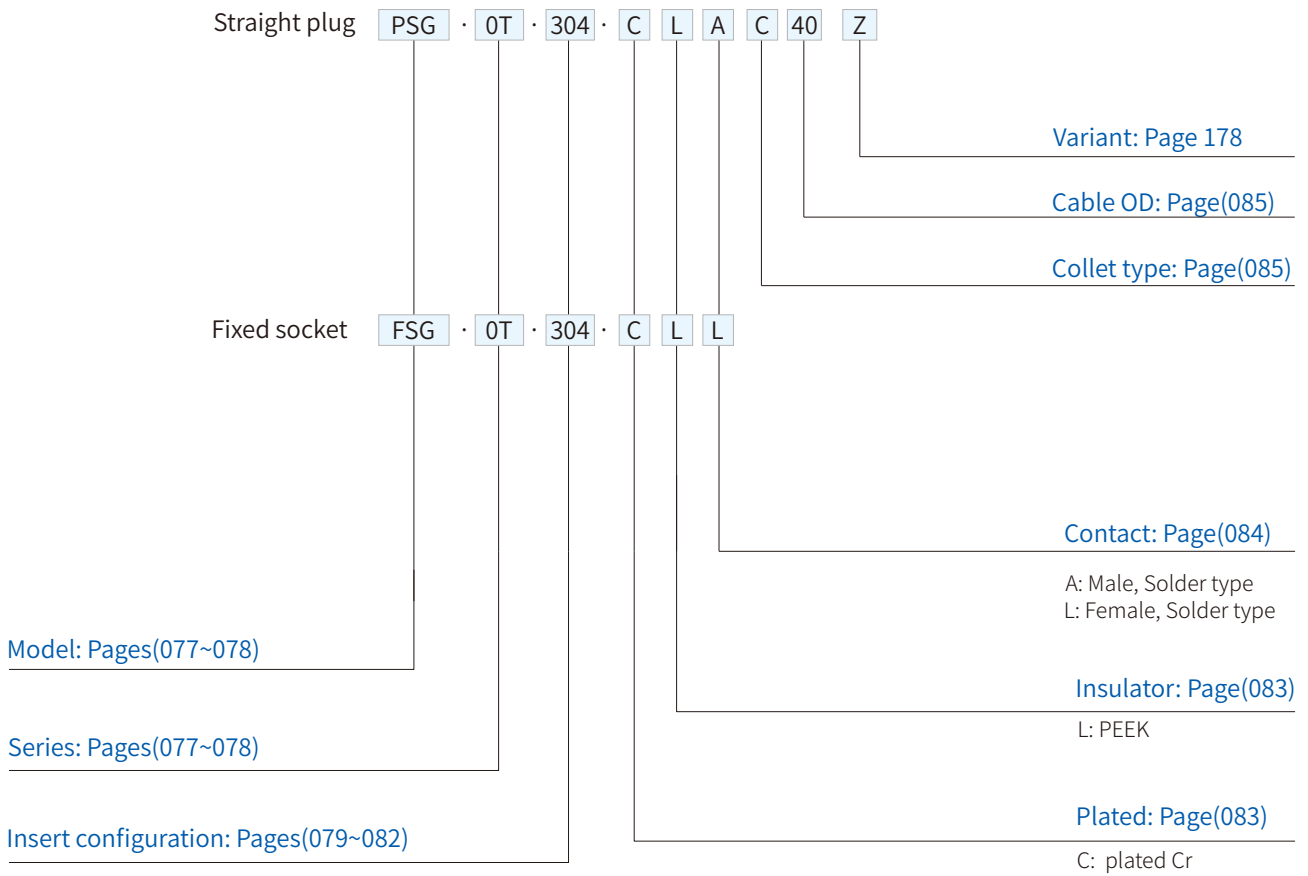

■ Part Number Example

Straight Plug With Cable Collet

PSG.OT.304.CLAC40= Straight plug with cable collet, G-key, OT series, multipole type with 4 male solder/crimp contacts, chrome-plated brass outershell, PEEK insulator, C type collet for 4.0mm diameter cable.

Free Socket

FSG.OT.304.CLL= Fixed socket, nut fixing, G-key, OT series, multipole type with 4 female solder/crimp contacts, chrome-plated brass outershell, PEEK insulator

PSG Straight Plug, Key(G), Cable Collet

- Connector series: PSG
- Contact: Male
- Locking type: Self-locking
- Orientation type: Straight
- Part No.: PSG.XT.XXX.CLACXX
- Mated with: FSG series

Note: "X" refers to part number definition on page 076

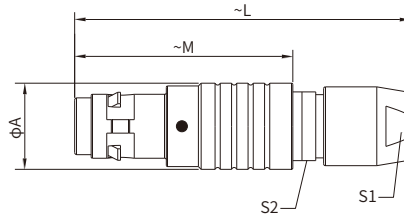

General Information

Ambient temperature:	-55°C ~ + 200°C	Seal/O-ring:	Silicone
Endurance:	>3000 cycles	Insulation resistance:	≥100MΩ
Insulator:	PEEK	IP rating:	IP68
Connector contacts:	Brass with gold plated	Shielding efficiency:	at 10MHz>75dB/at 1GHz>40dB
Housing:	Brass with Cr plated	Salt spray corrosion test:	>144h

Size	Dimensions(mm)				
	A	L	M	S1	S2
TT	7.0	33.2	25.2	5.0	5.5
0T	9.5	39.0	29.0	7.0	7.5
1T	12.0	46.0	35.0	9.0	11
2T	15.0	55.0	43.0	12.0	14
3T	18.8	64.0	49.0	14.0	16

FSG Fixed Socket, Nut Fixing, Key(G)

- Connector series: FSG
- Contact: Female
- Locking type: Self-locking
- Orientation type: Straight
- Part No.: FSG.XT.XXX.CLL
- Mated with: PSG series

Note: "X" refers to part number definition on page 076

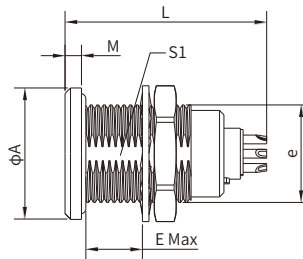

General Information

Ambient temperature:	-55°C ~ + 200°C	Seal/O-ring:	Silicone
Endurance:	>3000 cycles	Insulation resistance:	≥100MΩ
Insulator:	PEEK	IP rating:	IP68
Connector contacts:	Brass with gold plated	Shielding efficiency:	at 10MHz>75dB/at 1GHz>40dB
Housing:	Brass with Cr plated	Salt spray corrosion test:	>144h

Size	Dimensions(mm)					
	A	e	E	L	M	S1
TT	10.0	M7*0.5	5.5	16.0	1.2	6.3
0T	12.0	M9*0.6	6.0	21.0	1.5	8.2
1T	15.5	M12*1.0	6.0	23.0	1.8	10.5
2T	18.5	M15*1.0	7.5	26.5	1.8	13.5
3T	23.5	M18*1.0	9.6	30.1	2.5	16.5

Panel cut out(page 180)

■ SRG Fixed Socket, Key(G), Nut Fixing, Back Panel Mounting

- Connector series: SRG
- Contact: Female
- Key: G(More keys, refer to page 083)
- Locking type: Self-locking
- Orientation type: Straight
- Part No.: SRG.xT.3xx.xLL
- Mated with: PSG

Note: "X" refers to part number definition on page 076

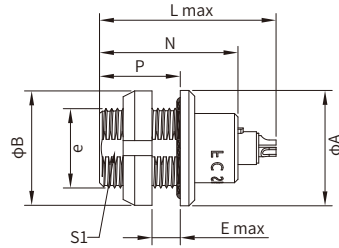

■ General Information

Ambient temperature:	-55°C ~ + 200°C
Endurance:	>3000 cycles
Insulator:	PEEK
Connector contacts:	Brass with gold plated
Housing:	Brass with Cr plated

O-Ring:	Silicone
Insulator resistance:	≥100MΩ
IP rating:	IP 68
Shielding efficiency:	at 10MHz>75dB/at 1GHz>40dB
Salt spray corrosion test:	>144h

Size	Dimensions(mm)							
	A	B	e	E	L	N	P	S1
TT	10.0	10.0	M7*0.5	4.5	16.0	13.5	7	6.3
0T	12.0	12.0	M9*0.6	6.5	21.0	19.1	9	8.2
1T	15.5	16.0	M12*1.0	6.5	23.0	21.5	10	10.5
2T	18.5	20.0	M15*1.0	7.5	26.5	24.6	11	13.5
3T	23.5	24.0	M18*1.0	7.5	30.1	25.0	12	16.5

Panel cut out(page 180)

■ SWG Fixed Socket, Nut Fixing, Watertight or Vacuumtight

- Connector series: SWG
- Contact: Female
- Locking type: Self-locking
- Orientation type: Socket
- Part No.: SWG.xT.3xx.xLL
- Mated with: PSG

Note: "X" refers to part number definition on page 076

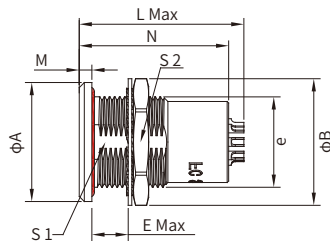

■ General Information

Ambient temperature:	-20°C ~ + 80 °C
Endurance:	>3000 cycles
Insulator:	PEEK
Connector contacts:	Brass with gold plated
Housing:	Brass with Cr plated

O-Ring:	Silicone
Insulator resistance:	≥100MΩ
IP rating:	IP 68
Shielding efficiency:	at 10MHz>75dB/at 1GHz>40dB
Salt spray corrosion test:	>144h

Size	Dimensions(mm)								
	A	B	e	E	L	M	N	S1	S2
TT	10.0	10.2	M7*0.5	4.5	18.0	1.2	15.0	6.3	9
0T	12.0	12.5	M9*0.6	6.5	22.0	1.5	18.5	8.2	11
1T	15.5	16.0	M12*1.0	6.0	26.0	1.8	21.5	10.5	14
2T	18.5	19.6	M15*1.0	8.0	30.5	1.8	25.0	13.5	17
3T	23.5	25.0	M18*1.0	10	35.5	2.5	29.5	16.5	22

Panel cut out(page 180)

■ Electrical & Mechanical Data

PSG · 0T · 304 · C L A C 40

Insert configuration

Size	Part.No	Pin Count	Pin layout From the direction of solder		Contact Dim (mm)	Rated current (A)	Contact type			Test voltage(KV rms)			
			Male	Female			Solder	Print	Crimp	Solder contact		Crimp contact	
										Contact and Contact	Contact and Shell	Contact and Contact	Contact and Shell
TT	302	02			0.5	5.0	●	●	●	1.00	0.95	1.15	1.20
	303	03			0.5	3.0	●	●	●	0.80	0.95	1.35	1.10
	304	04			0.5	2.0	●	●	●	0.80	0.65	1.05	1.05
	305	05			0.35	1.7	●	-	-	0.70	1.00	-	-
	306	06			0.35	1.5	●	-	-	0.60	0.75	-	-
0T	302	02			0.9	10.0	●	●	●	1.00	1.05	1.45	1.20
	303	03			0.9	8.0	●	●	●	1.20	0.90	1.70	1.60
	304	04			0.7	7.0	●	●	●	0.85	0.70	1.35	1.10
	305	05			0.7	6.5	●	●	●	1.00	0.70	1.25	1.20
	306	06			0.5	2.5	●	●	○	0.85	0.65	1.40	1.20
	307	07			0.5	2.5	●	●	○	0.80	0.70	1.40	1.20
	309	09			0.5	2.0	●	●	○	0.60	0.50	1.00	0.85
	312	12			0.35	1.5	●	●	-	0.80	1.00	-	-

Electrical & Mechanical Data

PSG · 0T · 304 · C L A C 40

Insert configuration

Size	Part.No	Pin Count	Pin layout From the direction of solder		Contact Dim (mm)	Rated current (A)	Contact type			Test voltage(KV rms)			
			Male	Female			Solder	Print	Crimp	Solder contact		Crimp contact	
										Contact and Contact	Contact and Shell	Contact and Contact	Contact and Shell
1T	302	02			1.3	15.0	●	●	●	1.50	1.35	1.70	1.45
	303	03			1.3	12.0	●	●	●	1.30	1.55	1.60	1.85
	304	04			0.9	10.0	●	●	●	1.35	1.45	1.70	1.80
	305	05			0.9	9.0	●	●	●	1.25	1.15	1.30	1.55
	306	06			0.7	7.0	●	●	●	1.05	1.20	1.35	1.45
	307	07			0.7	7.0	●	●	●	0.95	1.05	1.45	1.45
	308	08			0.7	5.0	●	●	●	0.95	1.15	1.30	1.30
	310	10			0.5	2.5	●	●	○	0.90	1.50	1.20	1.80
	314	14			0.5	2.0	●	●	○	0.80	1.20	0.95	1.60
	316	16			0.5	1.5	●	●	○	0.80	1.25	0.95	1.60

It is proposed according to the following ratio : Operating Voltage (Us) = Test voltage(Ue) / 3

● First Recommendation ○ Special order alternative

Caution:

For a number of applications, safety requirements for electrical appliances are more severe with regard to operating voltage.

In such cases operating voltage is defined according to creepage distance and air clearance) between live parts.

■ Electrical & Mechanical Data

Size	Part.No	Pin Count	Pin layout From the direction of solder		Contact Dim (mm)	Rated current (A)	Contact type			Test voltage(KV rms)			
			Male	Female			Solder	Print	Crimp	Solder contact		Crimp contact	
										Contact and Contact	Contact and Shell	Contact and Contact	Contact and Shell
2T	302	02			2.0	30.0	●	○	○	2.10	1.75	2.85	2.70
	303	03			1.6	17.0	●	○	○	2.40	1.85	1.90	1.90
	304	04			1.3	15.0	●	●	●	1.85	1.85	2.20	2.20
	305	05			1.3	14.0	●	●	●	1.75	1.60	2.15	2.15
	306	06			1.3	12.0	●	●	●	1.35	1.45	2.00	2.35
	307	07			1.3	11.0	●	●	●	1.75	1.60	1.95	2.15
	308	08			0.9	10.0	●	●	●	1.50	1.25	1.95	1.95
	310	10			0.9	8.0	●	●	●	1.45	1.30	1.80	2.10
	312	12			0.7	7.0	●	●	●	1.25	1.35	1.65	2.00
	314	14			0.7	6.5	●	●	●	1.15	1.35	1.55	1.95
	316	16			0.7	6.0	●	●	●	0.95	1.25	1.55	1.75
	318	18			0.7	5.5	●	●	●	0.85	1.20	1.45	2.10
	319	19			0.7	5.0	●	●	●	0.95	1.25	1.55	1.65
	326	26			0.5	2.0	●	●	—	0.95	1.30	1.20	1.80
	332	32			0.5	1.5	●	●	—	0.80	1.20	0.95	1.60

It is proposed according to the following ratio : Operating Voltage (Us) = Test voltage(Ue) / 3

● First Recommendation ○ Special order alternative

Caution:

For a number of applications, safety requirements for electrical appliances are more severe with regard to operating voltage.

In such cases operating voltage is defined according to creepage distance and air clearance) between live parts.

■ Electrical & Mechanical Data

Size	Part.No	Pin Count	Pin layout From the direction of solder		Contact Dim (mm)	Rated current (A)	Contact type			Test voltage(KV rms)			
			Male	Female			Solder	Print	Crimp	Solder contact		Crimp contact	
										Contact and Contact	Contact and Shell	Contact and Contact	Contact and Shell
3T	302	02			3.0	35.0	●	○	●	2.10	1.55	2.30	1.80
	303	03			2.0	25.0	●	●	●	1.90	1.50	3.20	2.65
	304	04			2.0	19.0	●	●	●	1.45	1.25	2.50	2.20
	305	05			1.6	19.0	●	●	●	1.90	1.25	2.40	1.75
	306	06			1.6	17.0	●	●	●	1.60	1.15	1.90	1.80
	307	07			1.6	15.0	●	●	●	1.70	1.25	2.00	2.05
	308	08			1.3	13.0	●	●	●	1.65	1.15	1.85	1.75
	514 (Cat 6A insulator)	08			0.7	10	○	○	●	-	-	1.5	1.5
	309	09			8x1.3 1x2.0	6.0 15.0	●	●	●	1.35 1.35	1.05 1.05	1.10 1.10	1.05 1.05
	310	10			1.3	12.0	●	●	●	1.25	0.90	1.50	1.80
	312	12			0.9	9.0	●	●	●	1.45	1.00	1.65	1.85
	314	14			0.9	9.0	●	●	●	1.20	1.20	1.80	1.65
	316	16			0.9	8.0	●	●	●	1.20	0.85	1.80	1.50
	318	18			0.9	7.0	●	●	●	1.20	1.05	1.85	1.60
	320	20			0.7	6.0	●	●	●	1.00	0.90	1.35	1.55
	322	22			0.7	5.5	●	●	●	1.00	0.90	1.70	1.45
	324	24			0.7	4.0	●	●	●	0.95	0.80	1.35	1.35
	326	26			0.7	4.0	●	●	●	0.95	0.70	1.50	1.30
	330	30			0.7	3.5	●	●	●	0.80	0.70	1.35	1.20

It is proposed according to the following ratio : Operating Voltage (Us) = Test voltage(Ue) / 3

● First Recommendation ○ Special order alternative

Caution:

For a number of applications, safety requirements for electrical appliances are more severe with regard to operating voltage.

In such cases operating voltage is defined according to creepage distance and air clearance) between live parts.

■ Alignment Key, Metal Material & Plate

PS G · OT · 302 · C L A C 30

Alignment key:

Code	No. of keys	Series					Contact type	
		TT	OT	1T	2T	3T	Plug	Socket
G	1	0°	0°	0°	0°	0°	Male	Female
A	2	30°	30°	30°	30°	30°	Male	Female
D	2	135°	135°	135°	-	-	Male	Female
L	2	-	80°	80°	70°	70°	Female	Male
J	2	45°	45°	45°	37.5°	37.5°	Female	Male

Note: 1. Front view of socket; 2. J¹⁾ only for 2T and 3T series.

Metal material&plate:

Reference	Out shell+collet nut		Latch sleeve+earth crown		Other metallic components		Remarks	Notes
	Material	Surftreatment	Material	Surftreatment	Material	Surftreatment		
C	Brass	Chrome	Brass-bronze	Nickel	Brass	Nickel		●
N	Brass	Nickel	Brass-bronze	Nickel	Brass	Nickel		○
K	Brass	Black Chrome	Brass-bronze	Nickel	Brass	Nickel		●
S	Stainless steel	-	Brass-bronze	Nickel	Brass	Nickel		●
P	PSU	-	Brass-bronze	Nickel	Brass	Nickel	Available for some parts of B series	●
H	PPS/Brass	-/Nickel	Brass-bronze	Nickel	Brass	Nickel	Only for elbow sockets (B series)	●

● First Recommendation ○ Special order alternative

■ Insulator & Contact Type

PS · G · OT · 305 · C L A C 42

Insulator&contact type

	Y	L
Insulator material	PEEK	PEEK
Contact type	Crimp	Solder or print

Contacts reference for plugs free or fixed sockets

Contact type	Reference		Contact (mm)		Conductor Size					
					Solid		Stranded			
	Male	Female	Pin OD	Wire OD	AWG max.	Section max. (mm ²)	AWG		Section (mm ²)	
						min.	max.	min.	max.	
Solder	A	L	0.5	0.4	28	0.09		30		0.05
			0.5	0.45	28	0.09		28		0.09
			0.7	0.8	22	0.34		22		0.34
			0.9	0.8	22	0.34		22		0.34
			1.3	1.0	20	0.50		20		0.50
			1.6	1.4	16	1.00		18		1.00
			2.0	1.8	14	1.50		16		1.50
			3.0	2.7	10	4.00		12		4.00
Crimp	C	M	0.5	0.45			32	28	0.035	0.09
	C	M	0.7	0.80			26	22	0.140	0.34
	B	P	0.7	0.45			32	28	0.035	0.09
	C	M	0.9	1.10			24	20	0.250	0.50
	B	P	0.9	0.80			26	22	0.140	0.34
	G	U	0.9	0.45			32	28	0.035	0.09
	C	M	1.3	1.40			20	18	0.500	1.00
	B	P	1.3	1.10			24	20	0.250	0.50
	G	U	1.3	0.80			26	22	0.140	0.34
	C	M	1.6	1.90			18	14	1.000	1.50
	B	P	1.6	1.40			22	18	0.340	1.00
	C	M	2.0	2.40			16	12	1.500	2.50
	B	P	2.0	1.90			18	14	1.000	1.50
C	M	3.0	2.90			14	10	2.500	4.00	
Print	D	N								
Print Angled	W	V								

■ Collet type

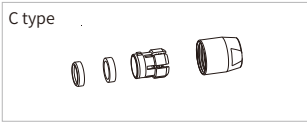

PS · G · OT · 304 · C L A C 40

— Cable OD
— Collet Type: C

Series	Reference		Cable OD	
	Type	Code	Max.	Min.
TT	C	27	2.6	2.4
	C	31	3.0	2.7
OT	C	10	1.2	1.0 ¹⁾
	C	15	1.5	1.3 ¹⁾
	C	20	2.0	1.6 ¹⁾
	C	25	2.5	2.1
	C	30	3.0	2.6
	C	35	3.5	3.1
	C	40	4.0	3.6
	C	45	4.5	4.1
	C	50	5.0	4.6
	1T	C	15	1.5
C		20	2.0	1.6
C		25	2.5	2.1
C		30	3.0	2.6
C		35	3.5	3.1
C		40	4.0	3.6
C		45	4.5	4.1
C		50	5.0	4.6
C		55	5.5	5.1
C		60	6.0	5.6
C		65	6.5	6.1
K		70	7.0	6.6 ²⁾
K		75	7.5	7.1 ²⁾
K		80	8.0	7.6 ²⁾
K		85	8.5	8.1 ²⁾
2T	C	15	1.5	1.3
	C	20	2.0	1.6
	C	25	2.5	2.1
	C	30	3.0	2.6
	C	35	3.5	3.1
	C	40	4.0	3.6
	C	45	4.5	4.1

Series	Reference		Cable OD		
	Type	Code	Max.	Min.	
2T	C	50	5.0	4.6	
	C	55	5.5	5.1	
	C	60	6.0	5.6	
	C	65	6.5	6.1	
	C	70	7.0	6.6	
	C	75	7.5	7.1	
	C	80	8.0	7.6	
	C	85	8.5	8.1	
	K	90	9.0	8.6 ³⁾	
	K	95	9.5	9.1 ³⁾	
	K	10	10.0	9.6 ³⁾	
	K	11	10.5	10.1 ³⁾	
	3T	C	30	3.0	2.6
		C	35	3.5	3.1
		C	40	4.0	3.6
C		45	4.5	4.1	
C		50	5.0	4.6	
C		55	5.5	5.1	
C		60	6.0	5.6	
C		65	6.5	6.1	
C		70	7.0	6.6	
C		75	7.5	7.1	
C		80	8.0	7.6	
C		85	8.5	8.1	
C		90	9.0	8.6	
C		95	9.5	9.1	
C		10	10.0	9.6	
C		11	10.5	10.1	
K		11	12.0	10.6	
K		12	12.8	12.1	
K	13	13.5	12.9		
K	14	14.0	13.6		
K	15	15.0	14.1		

Note: All dimensions unit are mm

- 1) The minimum internal longitude of the jacket is 2.5mm (TPU) / 1.7mm (silicone)
- 2) Use 2B series SR.bend relief
- 3) Use 3B series SR.bend relief
- 4) The maximum internal longitude of the jacket is 14.5mm

S Series

Key Features:

- Security of the Push-Pull self-latching system
- 360° screening for full emc shielding.
- Multipole types 2 to 10 contacts
- Solder or print contacts (straight or angled)
- Polarisation by stepped insert (half-moon) fitted with male and female contacts
- Coaxial triaxial, multipole, high voltage



■ Part Number Definition

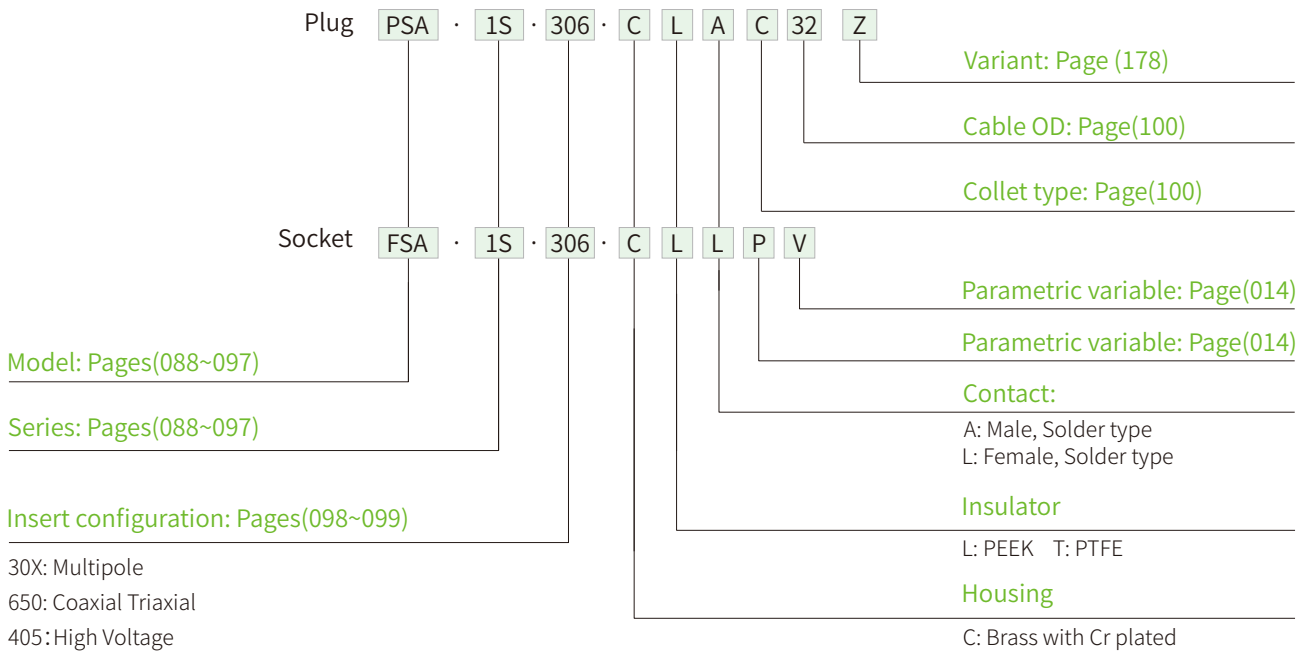

■ Part Number Example

Multipole

Straight plug with cable collet:

PSA.1S.306.CLAC32Z = straight plug with cable collet, 1S series, multipole type with 6 contacts, outer shell in chrome plated brass, PEEK insulator, 3 male and 3 female solder contacts, C type collet for a 3.2 mm diameter cable and with nut for bend relief.

Fixed socket:

FSA.1S.306.CLL = fixed socket, nut fixing, 1S series, multipole type with 6 contacts, outer shell in chrome-plated brass, PEEK insulator, 3 female and 3 male solder contacts.

Coaxial Triaxial

Straight plug with cable collet:

PSA.0S.650.CTAC32= straight plug with cable collet, 0S series, triax coaxial type, outershell in chrome plated brass, PTFE insulator, male solder contacts, C type collet for a 3.2 mm diameter cable.

Fixed socket:

FSA.0S.650.CTL= fixed socket, nut fixing, 0S series, triax coaxial type, outershell in chrome-plated brass, PTFE insulator, female solder contacts.

High Voltage

Straight plug with cable collet:

PSA.0S.405.CTAC32= straight plug with cable collet, 1S series, high voltage 7kv and safety locking, outer shell in chrome plated brass, PTFE insulator, male solder contacts. C type collet for a 3.2mm diameter cable.

Fixed socket:

FSB.1S.405.CTL=Fixed Socket, nut fixing, 1S series, high voltage 7kv, outer shell in chrome plated brass, PTFE insulator, female solder contact.

■ PSA Straight Plug, Half Moon, Cable Collet (Multipole)

- Connector series: PSA
- Contact: Hermaphroditic
- Locking type: Self-locking
- Orientation type: Straight
- Part No.: PSA.XS.30X. CLACXX
- Mated with: FSA series

Note: "X" refers to part number definition on page 087

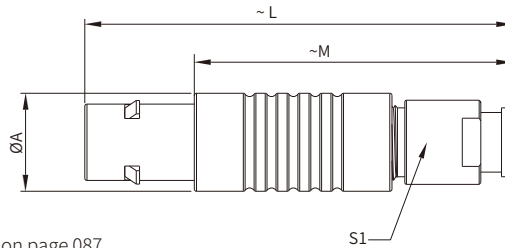

■ General Information

Ambient temperature:	-55°C~+250°C
Mating endurance:	>5000 cycles
Insulator:	PEEK
Housing:	Brass with gold plated
Connector contacts:	Brass with nickel plated

Insulation resistance:	≥ 100MΩ
IP rating:	IP 50
Shielding efficiency:	at 10MHz>75dB / at 1GHz>40dB
Salt spray corrosion test:	>144h

Size	Dimensions(mm)			
	A	L	M	S1
0S	9.0	34.5	24.5	6.5
1S	12.0	42.5	31.5	8.5
2S	14.8	52.0	40.0	11.0

■ FSA Fixed Socket, Half Moon, Nut Fixing (Multipole)

- Connector series: FSA
- Contact: Hermaphroditic
- Locking type: Self-locking
- Orientation type: Straight
- Part No.: FSA.XS.30X. CLL
- Mated with: PSA series

Note: "X" refers to part number definition on page 087

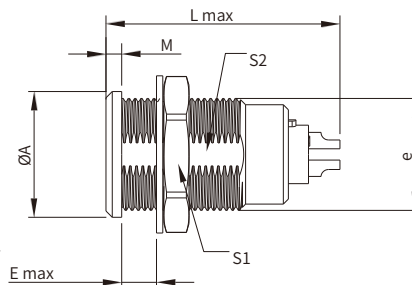

■ General Information

Ambient temperature:	-55°C~+250°C
Mating endurance:	>5000 cycles
Insulator:	PEEK
Housing:	Brass with gold plated
Connector contacts:	Brass with nickel plated

Coupling nut/screw:	Brass with nickel plated
Insulation resistance:	≥ 100MΩ
IP rating:	IP 50
Shielding efficiency:	at 10MHz>75dB / at 1GHz>40dB
Salt spray corrosion test:	>144h

Size	Dimensions(mm)					
	A	M	S1	S2	e	E
0S	10.0	1.2	11.0	8.2	M9*0.6	7.0
1S	14.0	1.5	14.0	10.5	M12*1.0	7.5
2S	18.0	1.8	17.0	13.5	M15*1.0	8.5

Note: Panel cut-out (page 180)

■ ALA Free Straight Plug (Multipole)

- Connector series: ALA
- Contact: Hermaphroditic
- Locking type: Self-locking
- Orientation type: Straight
- Part No.: ALA.XS.30X.CLLCXX
- Mated with: PSA series(Multipole)

Note: "X" refers to part number definition on page 087

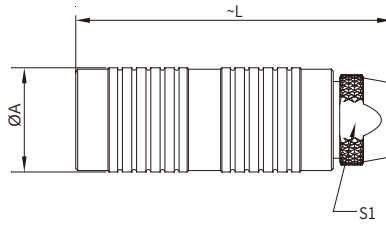

■ General Information

Ambient temperature:	-55°C~+250°C	Insulation resistance:	≥100MΩ
Endurance:	>5000 cycles	IP rating:	IP 50
Insulator:	PEEK	Shielding efficiency:	at 10MHz>75dB/at 1GHz>40dB
Housing:	Brass with Cr plated	Salt spray corrosion test:	>144h
Connector contacts:	Brass with gold plated		

Size	Dimensions(mm)		
	A	L	S1
0S	8.9	33.5	6.5
1S	11.9	40.5	8.5
2S	14.8	50.0	11.0

■ FRP Fixed Straight Socket, Nut Fixing, Protruding Shell (Multipole)

- Connector series: FRP
- Contact: Hermaphroditic
- Locking type: Self-locking
- Orientation type: Straight
- Part No.: FRP.XS.30X.CLL
- Mated with: PSA series

Note: "X" refers to part number definition on page 087

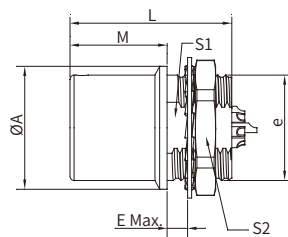

■ General Information

Ambient temperature:	-55°C~+250°C	Coupling nut/screw:	Brass with nickel plated
Endurance:	>5000 cycles	Insulation resistance:	≥100MΩ
Insulator:	PEEK	IP rating:	IP 50
Housing:	Brass with Cr plated	Shielding efficiency:	at 10MHz>75dB/at 1GHz>40dB
Connector contacts:	Brass with gold plated	Salt spray corrosion test:	>144h

Size	Dimensions(mm)						
	A	e	E	L Max	M	S1	S2
0S	10	M9*0.6	2.0	20.5	12.5	8.2	11
1S	14	M12*1.0	3.5	22.0	12.0	10.5	14

Note: Panel cut-out (page 180)

■ SWM Fixed Straight Socket, Key(G), Front Fastened

- Connector series: SWM
- Contact: Female
- Locking type: Self-locking
- Orientation type: Straight
- Part No.: SWM.xS.3xx.CLLPV
- Mated with: PSA.xS.3xx.CLACxx(Z)

Note: "X" refers to part number definition on page 087

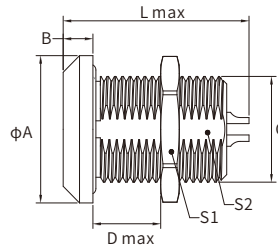

■ General Information

Ambient temperature:	-20°C ~ + 100°C
Endurance:	>5000 cycles
Insulator:	PEEK
Connector contacts:	Brass with gold plated
Coupling nut/screw:	Brass with nickel plated

Housing:	Brass with Cr plated
Insulator resistance:	≥100MΩ
Leakage rate(He):	<10 ⁻⁷ mbar.l.s ⁻¹
Shielding efficiency:	at 10MHz>75dB/at 1GHz>40dB
Salt spray corrosion test:	>144h

Size	Dimensions(mm)						
	A	B	C	D	L	S1	S2
0S	18	4.0	M12x1.0	11.5	20.5	10.5	14
1S	20	4.0	M14x1.0	15.5	25.0	12.5	17
2S	20	4.0	M16x1.0	17.0	29.5	14.5	19
3S	28	6.0	M20x1.0	18.0	33.0	18.5	24
4S	34	6.5	M25x1.0	22.5	39.0	23.5	30

Note: Panel cut-out (page 180)

■ PSA Straight Plug, Coaxial Triaxial, Cable Collet

- Connector series: 0S
- Contact: Male
- Locking type: Self-locking
- Orientation type: Straight
- Part No.: PSA.0S.650.CTACXX
- Mated with: FSA series

Note: "X" refers to part number definition on page 087

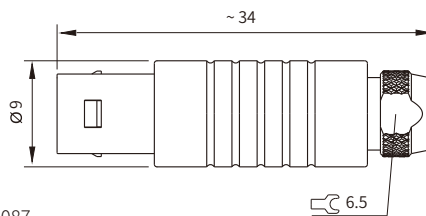

■ General Information

Ambient temperature:	-55°C~+250°C
Mating endurance:	>5000 cycles
Insulator:	PTFE
Housing:	Brass with Cr plated
Connector contacts:	Brass with gold plated

Insulation resistance:	≥100 MΩ
Impedance:	50Ω
IP rating:	IP50
VSWR:	1.03+0.34f(GHz)

PSA Straight Plug, Coaxial Triaxial, Cable Collet

- Connector series: 1S
- Contact: Male
- Locking type: Push-Pull Self-locking
- Orientation type: Straight
- Part No.: PSA.1S.650.CTACXX
- Mated with: FSA series

Note: "X" refers to part number definition on page 087

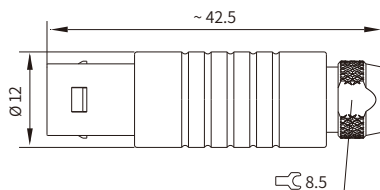

General Information

Ambient temperature:	-55°C~+250°C
Mating endurance:	>5000 cycles
Insulator:	PTFE
Housing:	Brass with gold plated
Connector contacts:	Brass with nickel plated

Insulation resistance:	≥100 MΩ
Impedance:	50Ω
IP rating:	IP50
VSWR:	1.01+0.17f(GHz)

FSA Fixed Straight Socket , Coaxial Triaxial

- Connector series: 0S
- Contact: Female
- Locking type: Push-Pull Self-locking
- Orientation type: Straight
- Part No.: FSA.0S.650.CTL
- Mated with: PSA series

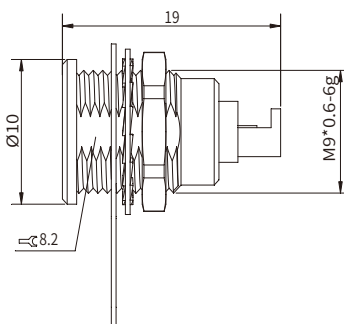

General Information

Ambient temperature:	-55°C~+250°C
Mating endurance:	>5000 cycles
Insulator:	PTFE
Housing:	Brass with Cr plated
Connector contacts:	Brass with gold plated

Insulation resistance:	≥100 MΩ
Impedance:	50Ω
IP rating:	IP68
VSWR:	1.03+0.34f(GHz)

Note: Panel cut-out (page 180)

FSA Fixed Straight Socket, Coaxial Triaxial

- Connector series: 1S
- Contact: Female
- Locking type: Push-Pull Self-locking
- Orientation type: Straight
- Part No.: FSA.1S.650.CTL
- Mated with: PSA series

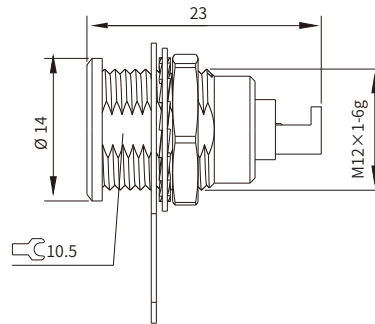

General Information

Ambient temperature:	-55°C~+250°C
Mating endurance:	>5000 cycles
Insulator:	PTFE
Housing:	Brass with Cr plated
Connector contacts:	Brass with gold plated

Coupling nut/screw:	Brass with nickel plated
Insulation resistance:	≥ 100 MΩ
Impedance:	50Ω
IP rating:	IP68
VSWR:	1.01+0.17f(GHz)

Note: Panel cut-out (page 180)

FSB (High Voltage), Fixed Socket, Nut Fixing

- Connector series: FSB
- Contact: Female
- Locking type: Self-locking
- Orientation type: Straight
- Part No.: FSB.1S.405.CTL
- Mated with: PSB series

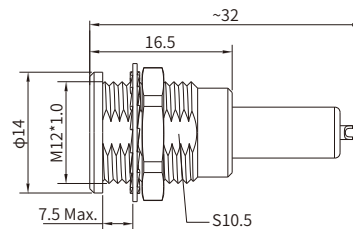

General Information

Ambient temperature:	-55°C ~ + 250°C
Endurance:	>5000 cycles
Insulator:	PTFE
Coupling nut/screw:	Brass with nickel plated
Connector contacts:	Brass with gold plated

Housing:	Brass with Cr plated
IP rating:	IP50
Shielding efficiency:	at 10MHz>75dB/at 1GHz>40dB
Salt spray corrosion test:	>144h

Reference	Insert configuration				
	Number of contacts	Contact φA (mm)	Supply voltage(KV dc)	AWG Max.	Rated current (A)
405	1	1.35	7	20	8

Note: Panel cut-out (page 180)

■ PSB (High Voltage), Straight Plug, Cable Collet And Safety Locking Ring

- Connector series: PSB
- Contact: Male
- Locking type: Self-locking
- Orientation type: Straight
- Part No.: PSB.1S.405.CTACXX
- Mated with: FSB series

Note: "X" refers to part number definition on page 087

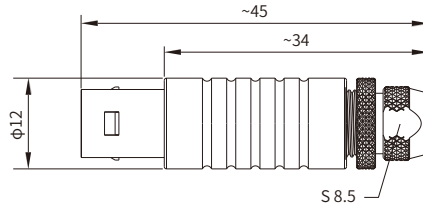

■ General Information

Ambient temperature:	-55 °C ~ + 250°C	Housing:	Brass with Cr plated
Endurance:	>5000 cycles	IP rating:	IP50
Insulator:	PTFE	Shielding efficiency:	at 10MHz>75dB/at 1GHz>40dB
Connector contacts:	Brass with gold plated	Salt spray corrosion test:	>144h

	Insert configuration					
	Reference	Number of contacts	Contact φA (mm)	Supply voltage(KV dc)	AWG Max.	Rated current (A)
	405	1	1.35	7	20	8

■ PSR (High Voltage) Free Straight Plug

- Connector series: PSR
- Contact: Male
- Locking type: Self-locking
- Orientation type: Straight
- Part No.: PSR.xS.408.CLAExx
- Mated with: FWS.xS.408.CLLPV

Note: "X" refers to part number definition on page 087

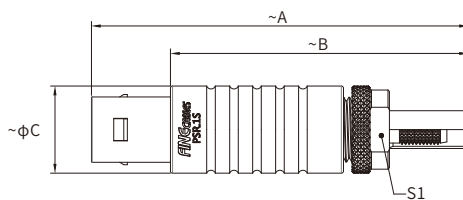

■ General Information

Ambient temperature:	-55°C ~ + 250°C	Housing:	Brass with Cr plated
Endurance:	>5000 cycles	Insulator resistance:	≥100MΩ
Insulator:	PEEK	IP rating:	IP 50
Connector contacts:	Brass with gold plated	Salt spray corrosion test:	>144h
Coupling nut/screw:	Brass with nickel plated	Shielding efficiency:	at 10MHz>75dB/at 1GHz>40dB

Size	Dimensions(mm)			
	A	B	C	S1
0S	42	32	9	6.5
1S	53	42	12	8.5

FWS High Voltage) Fixed Straight Socket, Rear Fastened

- Connector series: FWS
- Contact: Female
- Locking type: Self-locking
- Orientation type: Straight
- Part No.: FWS.XS.408.CLLPV
- Mated with: PSR.XS.408.CLAExx

Note: "X" refers to part number definition on page 087

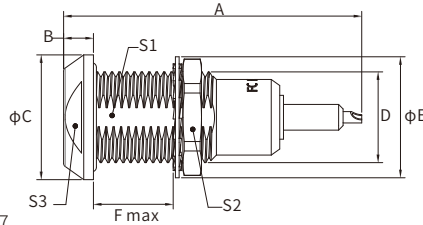

General Information

Ambient temperature:	-20°C ~ + 100°C
Endurance:	>5000 cycles
Insulator:	PEEK
Connector contacts:	Brass with gold plated
Coupling nut/screw:	Brass with nickel plated
Housing:	Brass with Cr plated

Insulator resistance:	≥100MΩ
Leakage rate(He):	<10 ⁻⁷ mbar.l.s ⁻¹
Salt spray corrosion test:	>144h
IP rating:	IP50
Shielding efficiency:	at 10MHz>75dB/at 1GHz>40dB

Size	Dimensions(mm)								
	A	B	C	D	E	F	S1	S2	S3
0S	34.0	3.5	13	M9x0.6	12.5	10.0	-	11	11
1S	40.0	4.0	16.5	M12x1.0	16.0	10.0	10.5	14.0	13.0

Note: Panel cut-out (page 180)

HWR Fixed Coupler, Nut Fixing, Watertight Or Vacuumtight

- Connector series: HWR
- Contact: N/A
- Key: N/A
- Locking type: Self locking
- Orientation type: Straight
- Part No.: HWR.XS.3XX.CLLPV
- Mated with: PSA.XS.3XX

Note: "X" refers to part number definition on page 087

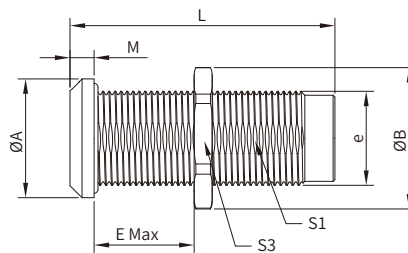

General Information

Ambient temperature:	-55°C~+250°C
Endurance:	>5000 cycles
Insulator:	PEEK
Connector contacts:	Brass with gold plated
Coupling nut/screw:	Brass with nickel plated

Housing:	Brass with Cr plated
Insulator resistance:	≥100MΩ
IP rating:	IP 68(Panel)
Vacuumtight:	See table
Salt spray corrosion test:	>144h

Reference		Dimensions(mm)									Vacuumtight (bars)
Model	Series	A	B	e	E	L	M	S1	S3		
HWR	0S	14	13.8	M10x0.75	17	34	2.0	9.0	12	60	
HWR	1S	17	15.8	M12x1.00	28	39	2.5	10.5	14	60	
HWR	2S	20	21.5	M16x1.00	25	44	4.0	15.0	19	40	

■ FLD Fixed Socket With Two Nuts (Back Panel Mounting)

- Connector series: FLD
- Contact: Female
- Locking type: Self-locking
- Orientation type: Socket
- Part No.: FLD.xx.6xx.CTL
- Mated with: PSA

Note: "X" refers to part number definition on page 087

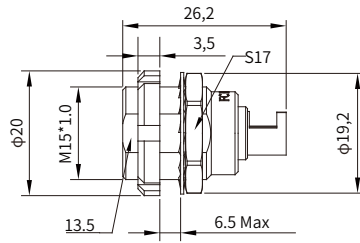

■ General Information

Ambient temperature:	-55 °C ~ + 250 °C
Endurance:	>5000 cycles
Insulator:	PTFE
Connector contacts:	Brass with gold plated
Housing:	Brass with Cr plated
Impedance:	50Ω/75Ω

Insulator resistance:	≥100MΩ
VSWR:	Page 099
IP rating:	IP 50
Shielding efficiency:	at 10MHz>75dB/at 1GHz>40dB
Salt spray corrosion test:	>144h

■ CHG Plug Caps, Nut Fixing or Flange

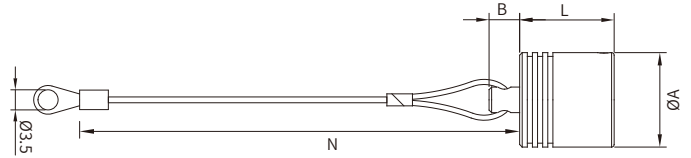

■ General Information

Ambient temperature:	maximum 135 °C
Endurance:	>5000 cycles
Body material:	Brass with nickel plated
Lanyard material:	Stainless steel

Crimp ferrule material:	Brass with nickel plated
Ip rating:	IP50
Salt spray corrosion test:	>144h

Part number	Size	Dimensions(mm)			
		A	B	L	N
CHG.00.100.PCS	00	7.5	4	10.0	100
CHG.0S.100.PCS	0S	9.5	5	12.2	120
CHG.1S.100.PCS	1S	12.0	6	13.8	120
CHG.2S.100.PCS	2S	15.0	6	15.0	150
CHG.3S.100.PCS	3S	18.5	6	18.5	150
CHG.4S.100.PCS	4S	25.0	10	20.2	200

Note: This cap is available only with an alignment key (G). The last letter "S" of part number stands for the material of the O-ring (silicone rubber). O-ring's made from FPM are also available; if required, replace the letter "S" by "V"

■ CFG Plug Caps, Sliding Loop

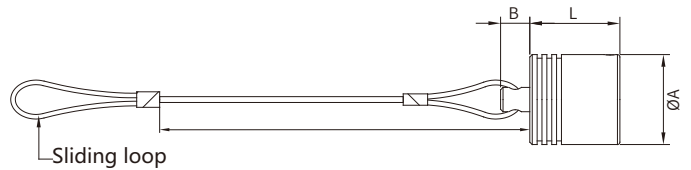

■ General Information

Ambient temperature:	maximum 135 °C
Endurance:	>5000 cycles
Body material:	Brass with nickel plated
Lanyard material:	Stainless steel

Crimp ferrule material:	Brass with nickel plated
Ip rating:	IP50
Salt spray corrosion test:	>144h

Part number	Size	Dimensions(mm)			
		A	B	L	N
CFG.00.100.PCS	00	7.5	4	10.0	100
CFG.0S.100.PCS	0S	9.5	5	12.2	120
CFG.1S.100.PCS	1S	12.0	6	13.8	120
CFG.2S.100.PCS	2S	15.0	6	15.0	150
CFG.3S.100.PCS	3S	18.5	6	18.5	150
CFG.4S.100.PCS	4S	25.0	10	20.2	200

Note: This cap is available only with an alignment key (G). The last letter "S" of part number stands for the material of the O-ring (silicone rubber). O-ring's made from FPM are also available; if required, replace the letter "S" by "V"

■ CRE Blanking Caps For Fixed Sockets

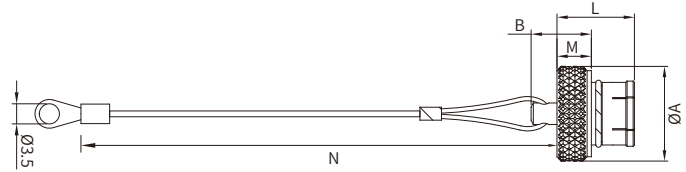

■ General Information

Ambient temperature:	maximum 135 °C
Endurance:	>5000 cycles
Body material:	Brass with nickel plated
Lanyard material:	Stainless steel

Crimp ferrule material:	Brass with nickel plated
Ip rating:	IP50
Salt spray corrosion test:	>144h

Part number	Size	Dimensions(mm)				
		A	B	L	M	N
CRE.00.200.NAS	00	8	7.5	8.5	3.5	100
CRE.0S.200.NAS	0S	10	9.5	10.5	4.5	120
CRE.1S.200.NAS	1S	14	11.5	12.5	5.5	120
CRE.2S.200.NAS	2S	18	12.0	14.0	6.0	150
CRE.3S.200.NAS	3S	22	14	18.0	8.0	150
CRE.4S.200.NAS	4S	28	20.0	23.0	10.0	200

Note: This cap is available only with an alignment key (G). The last letter "S" of part number stands for the material of the O-ring (silicone rubber). O-ring's made from FPM are also available; if required, replace the letter "S" by "V"

■ CRF Blanking Caps For Fixed Sockets, Sliding Loop

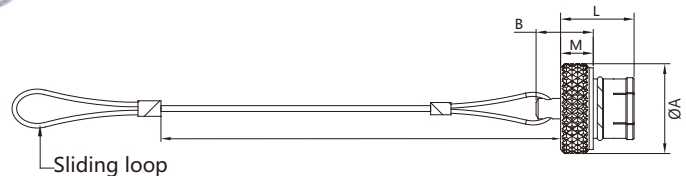

■ General Information

Ambient temperature:	maximum 135 °C
Endurance:	>5000 cycles
Body material:	Brass with nickel plated
Lanyard material:	Stainless steel

Crimp ferrule material:	Brass with nickel plated
Ip rating:	IP50
Salt spray corrosion test:	>144h

Part number	Size	Dimensions(mm)				
		A	B	L	M	N
CRF.00.200.NAS	00	8	7.5	8.5	3.5	100
CRF.0S.200.NAS	0S	10	9.5	10.5	4.5	120
CRF.1S.200.NAS	1S	14	11.5	12.5	5.5	120
CRF.2S.200.NAS	2S	18	12.0	14.0	6.0	150
CRF.3S.200.NAS	3S	22	14	18.0	8.0	150
CRF.4S.200.NAS	4S	28	20.0	23.0	10.0	200

Note: This cap is available only with an alignment key (G). The last letter "S" of part number stands for the material of the O-ring (silicone rubber). O-ring's made from FPM are also available; if required, replace the letter "S" by "V"

■ Electrical & Mechanical Data (Multipole)

PSA · 1S · 306 · C L A C 32 Z

Insert configuration

Size	Part.No	Pin Count	Pin layout		Contact Dim (mm)	Rated current (A)	Contact type	Test voltage (KV rms)
			Male	Female				
0S	302	02			0.9	10	Solder	1.1
	303	03			0.7	7	Solder	1.0
	304	04			0.7	7	Solder	1.0
1S	302	02			1.3	15	Solder	1.2
	303	03			0.9	10	Solder	1.2
	304	04			0.9	10	Solder	1.2
	305	05			0.9 0.7	10 7	Solder	1.5 1.5
	306	06			0.7	7	Solder	1.2
2S	302	02			1.6	20	Solder	1.7
	303	03			1.3	15	Solder	1.5
	304	04			1.3	15	Solder	1.7
	305	05			1.3	13	Solder	1.5
	306	06			1.3	12	Solder	1.5
	307	07			1.3 0.9	12 9	Solder	0.8 0.8
	308	08			0.9	9	Solder	0.8
	310	10			0.9	7	Solder	0.8

It is proposed according to the following ratio : Operating Voltage (Us) = Test voltage(Ue) / 3

Caution:

For a number of applications, safety requirements for electrical appliances are more severe with regard to operating voltage. In such cases operating voltage is defined according to creepage distance and air clearance) between live parts.

■ Electrical & Mechanical Data (Coaxial Triaxial)

PSA · 1S · 650 · C L A C 32 Z

Insert configuration

Size	Part.No	Pin Count	Pin layout From the direction of solder	Impedance (Ω)	Contact Dim (mm)	Rated current (A)	VSWR (GHz)	Test voltage (KV rms)
0S	650	01		50	0.9	6	1.03+0.34f	1.0
1S	650	01		50	0.9	6	1.01+0.17f	1.0
2S	650	01		50	1.6	12	1.01+0.3f	1.5
	675	01		75	0.9	6	1.01+0.07f	1.5

■ Contact Type (S series)

PSA · 1S · 306 · C L A C 32 Z

Contacts reference for plugs free or fixed sockets

Contact type	Reference		Contact (mm)		Conductor Size					
					Solid		Stranded			
	Male	Female	Pin OD	Wire OD	AWG max.	Section max. (mm ²)	AWG		Section (mm ²)	
						min.	max.	min.	max.	
Solder	A	L	0.7	0.60	24	0.25	-	26	-	0.14
			0.9	0.80	22	0.34	-	22	-	0.34
			1.3	1.00	20	0.50	-	20	-	0.50
			1.6	1.40	16	1.00	-	18	-	1.00
			2.0	1.80	14	1.50	-	16	-	1.50
			3.0	2.70	10	4.00	-	12	-	4.00
			4.0	3.70	10	6.00	-	10	-	6.00
			5.0	5.20	-	-	-	8	-	10.00
			6.0	5.20	-	-	-	8	-	10.00
			8.0	7.00	-	-	-	4	-	21.00
12.0	11.50	-	-	-	0	-	50.00			

■ Collet Type

0S · 650 · C T A C 37
 PSA · 1S · 306 · C L A C 32

Suitable for S series (Coaxial Triaxial / Multipole / High Voltage) Collet Type C

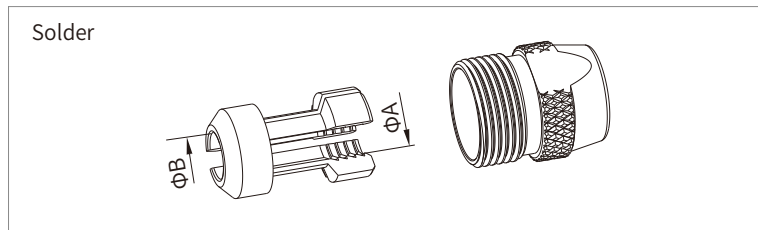

— Cable OD
 — Collet Type

Series	Reference		Collet OD		Cable OD	
	Type	Code	A	B	max.	min.
0S	C	22	2.2	-	2.1	1.7
	C	32	3.2	-	3.1	2.1
	C	37	3.7	-	3.6	3.1
	C	44	4.4	3.7	4.3	3.6
1S	C	22	2.2	-	2.1	1.7
	C	32	3.2	-	3.1	2.1
	C	42	4.2	-	4.1	3.1
	C	52	5.2	-	5.1	4.1
	C	57	5.7	5.2	5.6	5.1
	C	62	6.2	5.2	6.1	5.6
2S	C	27	2.7	-	2.6	2.2
	C	32	3.2	-	3.1	2.6
	C	42	4.2	-	4.1	3.1
	C	52	5.2	-	5.1	4.1
	C	62	6.2	-	6.1	5.1
	C	72	7.2	6.7	7.1	6.1
	C	82	8.2	6.7	8.1	7.1
	C	87	8.7	6.7	8.6	8.1

Note: All unit sizes are in mm.

00 Coaxial Series

Key Features:

The 00 series is a range of 50Ω coaxial connectors. They are suitable for a wide variety of applications particularly in measurement, control system and nuclear physics, having formed the basis for the NIM-CAMAC CD/N 549 standard. The plugs and sockets of the 01 series are amongst the smallest available 50 Ω coax connectors with a self-latching intermating capability. In spite of their small size and light weight, their technical characteristics remain excellent. Available in a wide range of housing configurations, they are especially useful when connecting onto printed circuitboards.

- Self-latching push-pull system
- High packing density
- Low weight
- Aesthetically pleasing appearance
- Rugged construction
- Reliable performances
- Small size
- Ease of use
- Wide choice to suit application



Part Number Definition

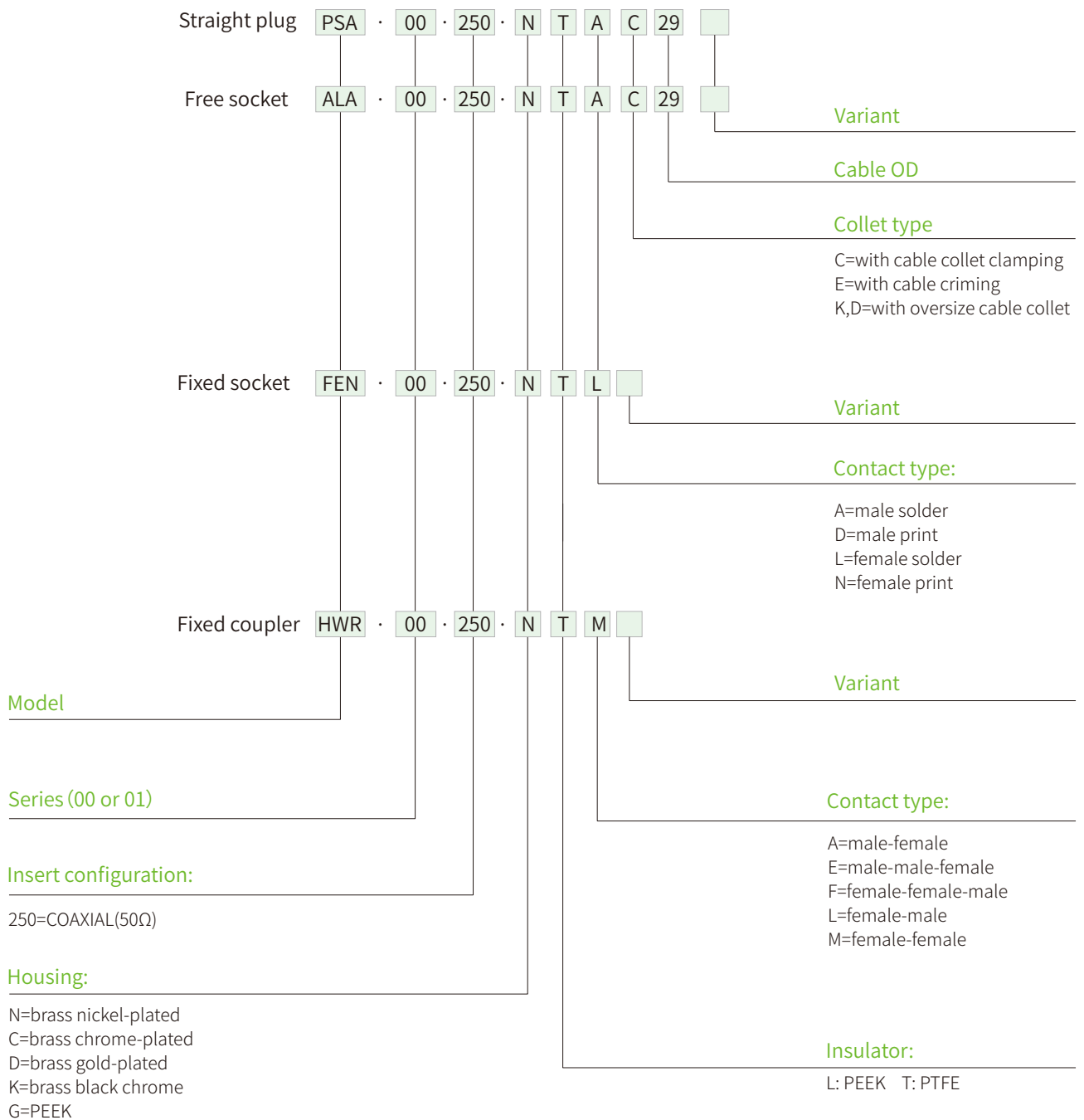

Part Number Example

Straight plug and nut for bend relief

PSA.00.250.NTAC29 = straight plug with cable collet, series 00, coaxial type (50Ω), nickel-plated brass outershell, PTFE insulator, male solder contact, C type collet of 2.9 mm diameter.

■ FAA Straight Socket For Printed Circuit

- Connector series: FAA-FAB
- Contact: Female print PCB
- Locking type: Self-locking
- Orientation type: Straight
- Part No.: FAA/FAB.00.250.NTN
- Mated with: PSA/PSC/PMS/PAS/PAV

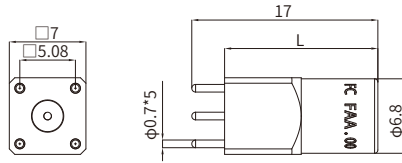

■ General Information

Ambient temperature:	-55°C ~ + 260°C
Endurance:	>5000 cycles
Insulator:	PTFE
Connector contacts:	Brass with gold plated
Housing:	Brass with nickel plated
Impedance:	50Ω
Operating Voltage:	0.7k V

Rated current:	4A
Insulator resistance:	≥100MΩ
VSWR:	1.09+0.11*f/GHz
IP rating:	IP 50
Shielding efficiency:	at 10MHz>75dB/at 1GHz>40dB
Salt spray corrosion test:	>144h

Part number	L(mm)	Weight(g)
FAA.00.250.NTN	14	3.4
FAB.00.250.NTN	12	3.3

PCB drilling pattern (page 187)

■ FAY Elbow Socket (90°) for Printed Circuit, With Two Vertical Sockets

- Connector series: FAY
- Contact: Female print PCB
- Locking type: Self-locking
- Orientation type: Angled
- Part No.: FAY.00.250.NTN
- Mated with: PSA/PSC/PMS/PAS/PAV

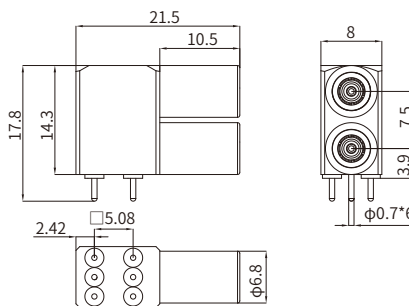

■ General Information

Ambient temperature:	-55°C ~ + 260°C
Endurance:	>5000 cycles
Insulator:	PTFE
Connector contacts:	Brass with gold plated
Housing:	Brass with nickel plated
Impedance:	50Ω
Operating Voltage:	0.7k V

Rated current:	4A
Insulator resistance:	≥100MΩ
VSWR:	1.09+0.11*f/GHz
IP rating:	IP 50
Shielding efficiency:	at 10MHz>75dB/at 1GHz>40dB
Salt spray corrosion test:	>144h

Part number	Weight(g)
FAY.00.250.NTN	12.8

PCB drilling pattern (page 187)

■ HWR Fixed Coupler, Nut Fixing, Vacuumtight

- Connector series: HWR
- Contact: Female-Female
- Locking type: Self-locking
- Orientation type: Straight
- Part No.: HWR.00.250.NTMV
- Mated with: PSA/PSC/PMS/PAS/PAV

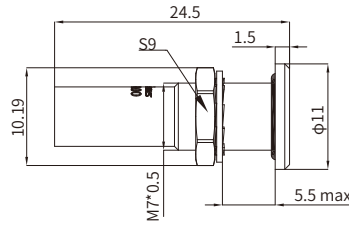

■ General Information

Ambient temperature:	-55°C ~ + 260°C
Endurance:	>5000 cycles
Insulator:	PTFE
Connector contacts:	Brass with gold plated
Housing:	Brass with nickel plated
Impedance:	50Ω
Operating Voltage:	0.7k V

Rated current:	4A
Insulator resistance:	≥100MΩ
VSWR:	1.09+0.11*f/GHz
IP rating:	IP 50
Shielding efficiency:	at 10MHz>75dB/at 1GHz>40dB
Salt spray corrosion test:	>144h

Part number	Weight(g)
HWR.00.250.NTMV	5.2

Note: this model is sealed with o-ring(no epoxy) Panelcut-out (page 187)

■ FAP Elbow Socket(90°) For Printing Circuit

- Connector series: FAP
- Contact: Female print PCB
- Locking type: Self-locking
- Orientation type: Angled
- Part No.: FAP.00.250.NTN
- Mated with: PSA/PSC/PMS/PAS/PAV

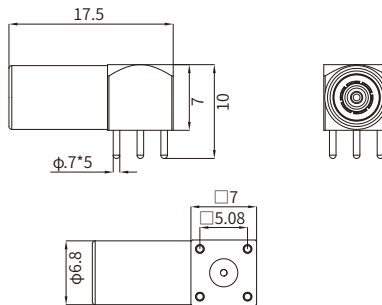

■ General Information

Ambient temperature:	-55°C ~ + 260°C
Endurance:	>5000 cycles
Insulator:	PTFE
Connector contacts:	Brass with gold plated
Housing:	Brass with nickel plated
Impedance:	50Ω
Operating Voltage:	0.7k V

Rated current:	4A
Insulator resistance:	≥100MΩ
VSWR:	1.09+0.11*f/GHz
IP rating:	IP 50
Shielding efficiency:	at 10MHz>75dB/at 1GHz>40dB
Salt spray corrosion test:	>144h

Part number	Weight(g)
FAP.00.250.NTN	4.3

PCB drilling pattern (page 187)

FEN Fixed Socket, Nut Fixing, With Earthing Tags

- Connector series: FEN
- Contact: Female
- Locking type: Self-locking
- Orientation type: Straight
- Part No.: FEN.00.250.CTL
- Mated with: PSA/PSC/PMS/PAS/PAV

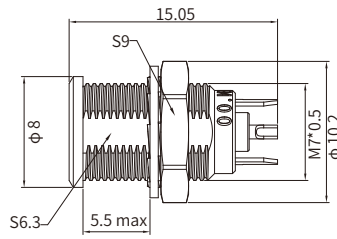

General Information

Ambient temperature:	-55°C ~ + 260°C	Rated current:	4A
Endurance:	>5000 cycles	Insulator resistance:	≥100MΩ
Insulator:	PTFE	VSWR:	1.09+0.11*f/GHz
Connector contacts:	Brass with gold plated	IP rating:	IP 50
Housing:	Brass with Cr plated	Shielding efficiency:	at 10MHz>75dB/at 1GHz>40dB
Impedance:	50Ω	Salt spray corrosion test:	>144h
Operating Voltage:	0.7k V		

Part number	Weight(g)
FEN.00.250.CTL	2.5

PCB drilling pattern (page 187)

PSA Straight Plug With Cable Collet

- Connector series: PSA
- Contact: Male
- Locking type: Self-locking
- Orientation type: Straight
- Part No.: PSA.00.250.xTACxx
- Mated with: FAA/FAY/HWR/FAP/FEN

Note: "x" detail information see the table below

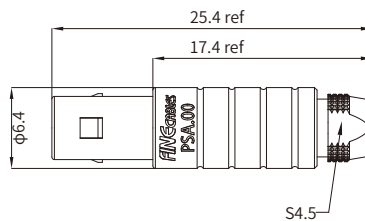

General Information

Ambient temperature:	-55°C ~ + 260°C	Rated current:	4A
Endurance:	>5000 cycles	Insulator resistance:	≥100MΩ
Insulator:	PTFE	VSWR:	1.09+0.11*f/GHz
Connector contacts:	Brass with gold plated	IP rating:	IP 50
Housing:	Brass with Cr plated	Shielding efficiency:	at 10MHz>75dB/at 1GHz>40dB
Impedance:	50Ω	Salt spray corrosion test:	>144h
Operating Voltage:	0.7k V		

Part number	Cond. φmax	Dielectric φmax	Sheathφ	
			min	max
PSA.00.250.CTAC15	0.55	1.45	1.1	1.4
PSA.00.250.CTAC17	0.55	1.45	1.3	1.7
PSA.00.250.CTAC22	0.55	1.95	1.8	2.2
PSA.00.250.CTAC27	0.55	1.95	2.3	2.7
PSA.00.250.CTAC31	0.55	1.95	2.8	3.0

PSA Straight Plug With Cable Collet

- Connector series: PSA
- Contact: Male
- Locking type: Self-locking
- Orientation type: Straight
- Part No.: PSA.00.250.xTACxxZ
- Mated with: FAA/FAY/HWR/FAP/FEN

Note: "x" detail information see the table below

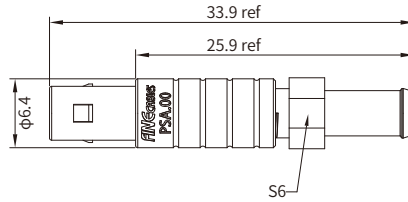

General Information

Ambient temperature:	-55°C ~ + 260°C
Endurance:	>5000 cycles
Insulator:	PTFE
Connector contacts:	Brass with gold plated
Housing:	Brass with Cr plated
Impedance:	50Ω
Operating Voltage:	0.7k V

Rated current:	4A
Insulator resistance:	≥100MΩ
VSWR:	1.09+0.11*f/GHz
IP rating:	IP 50
Shielding efficiency:	at 10MHz>75dB/at 1GHz>40dB
Salt spray corrosion test:	>144h

Part number	Cond. φmax	Dielectric φmax	Sheathφ	
			min	max
PSA.00.250.CTAC15Z	0.55	1.45	1.1	1.4
PSA.00.250.CTAC17Z	0.55	1.45	1.3	1.7
PSA.00.250.CTAC22Z	0.55	1.95	1.8	2.2
PSA.00.250.CTAC27Z	0.55	1.95	2.3	2.7
PSA.00.250.CTAC31Z	0.55	1.95	2.8	3.0

PPN Straight Plug, Non-latching, Nut Fixing

- Connector series: PPN
- Contact: Male
- Locking type: Non-latching
- Orientation type: Plug
- Part No.: PPN.00.250.CLA
- Mated with: FAA/FAY/HWR/FAP/FEN

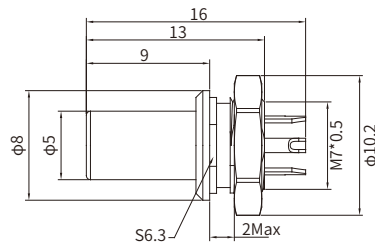

General Information

Ambient temperature:	-55 °C ~ + 260 °C
Endurance:	>5000 cycles
Insulator:	PTFE
Connector contacts:	Brass with gold plated
Housing:	Brass with Cr plated
Impedance:	50Ω

Rated current:	4A
Insulator resistance:	≥100MΩ
VSWR:	1.09+0.11*f/GHz
IP rating:	IP 50
Shielding efficiency:	at 10MHz>75dB/at 1GHz>40dB
Salt spray corrosion test:	>144h

Part number	Weight(g)
PPN.00.250.CLA	2.5

PCB drilling pattern (page 187)

■ PLF Straight Plug, Non-latching, With Cable Collet

- Connector series: PLF
- Contact: Male
- Locking type: Non-latching
- Orientation type: Plug
- Part No.: PLF.00.250.xTACxx
- Mated with: FAA/FAY/HWR/FAP/FEN

Note: "x" detail information see the table below

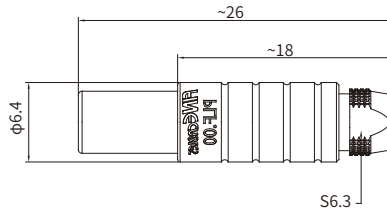

■ General Information

Ambient temperature:	-55 °C ~ + 260 °C	Rated current:	4A
Endurance:	>5000 cycles	Insulator resistance:	≥100MΩ
Insulator:	PTFE	VSWR:	1.09+0.11*f/GHz
Connector contacts:	Brass with gold plated	IP rating:	IP 50
Housing:	Brass with Cr plated	Shielding efficiency:	at 10MHz>75dB/at 1GHz>40dB
Impedance:	50Ω	Salt spray corrosion test:	>144h

Part number	Cond. φmax	Dielectric φmax	Sheathφ	
			min	max
PLF.00.250.CTAC22	0.55	1.95	1.7	2.1
PLF.00.250.CTAC27	0.55	1.95	2.3	2.7
PLF.00.250.CTAC31	0.55	1.95	2.8	3.0

■ PSY Straight Plug, Large Shell With Cable Collet

- Connector series: PSY
- Contact: Male
- Locking type: Self-locking
- Orientation type: Plug
- Part No.: PSY.00.250.xTACxx
- Mated with: FAA/FAY/HWR/FAP/FEN

Note: "x" detail information see the table below

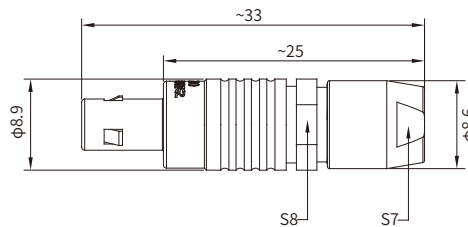

■ General Information

Ambient temperature:	-55 °C ~ + 260 °C	Rated current:	4A
Endurance:	>5000 cycles	Insulator resistance:	≥100MΩ
Insulator:	PTFE	VSWR:	1.09+0.11*f/GHz
Connector contacts:	Brass with gold plated	IP rating:	IP 50
Housing:	Brass with Cr plated	Shielding efficiency:	at 10MHz>75dB/at 1GHz>40dB
Impedance:	50Ω	Salt spray corrosion test:	>144h

Part number	Cond. φmax	Dielectric φmax	Sheathφ	
			min	max
PSY.00.250.CTAC40	1.05	3.05	3.2	3.8
PSY.00.250.CTAC47	1.05	3.05	3.9	4.5
PSY.00.250.CTAC52	1.05	3.05	4.6	5.0

FSA Fixed Socket, Nut Fixing

- Connector series: FSA
- Contact: Female
- Locking type: Self-locking
- Orientation type: Socket
- Part No.: FSA.00.250.CTL
- Mated with: PSA/PSC/PMS/PAS/PAV

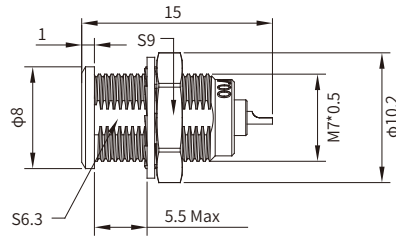

General Information

Ambient temperature:	-55 °C ~ + 260 °C
Endurance:	>5000 cycles
Insulator:	PTFE
Connector contacts:	Brass with gold plated
Housing:	Brass with Cr plated
Impedance:	50Ω

Rated current:	4A
Insulator resistance:	≥100MΩ
VSWR:	1.09+0.11*f/GHz
IP rating:	IP 50
Shielding efficiency:	at 10MHz>75dB/at 1GHz>40dB
Salt spray corrosion test:	>144h

Part number	Weight(g)
FSA.00.250.CTL	2.5

PCB drilling pattern (page 187)

■ PMS Straight Plug For Cable Crimping

- Connector series: PMS
- Contact: Male (Solder&Crimp)
- Locking type: Self-locking
- Orientation type: Straight
- Part No.: PMS.00.250.xTxExx
- Mated with: FAA/FAY/HWR/FAP/FEN

Note: "x" detail information see the table below

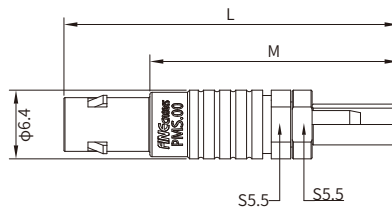

■ General Information

Ambient temperature:	-55°C ~ + 260°C
Endurance:	>5000 cycles
Insulator:	PTFE
Connector contacts:	Brass with gold plated
Housing:	Brass with Cr plated
Impedance:	50Ω
Operating Voltage:	0.7kV

Rated current:	4A
Insulator resistance:	≥100MΩ
VSWR:	1.09+0.11*f/GHz
IP rating:	IP 50
Shielding efficiency:	at 10MHz>75dB/at 1GHz>40dB
Salt spray corrosion test:	>144h

Part number	Dim		Cond. φmax	Dielectric φmax	Sheath φmax
	L	M			
PMS.00.250.CTAE24	31	23	0.4	0.95	2.35
PMS.00.250.CTAE31	31	23	0.55	1.65	3.0
PMS.00.250.CTAE52	34	26	0.97	3.05	5.2

Note: Solder contact

Part number	Dim		Cond. φmax		Dielectric φmax	Sheath φmax
	L	M				
PMS.00.250.CTCE24	31	23	0.28	0.4	0.95	2.35
PMS.00.250.CTCE25	31	23	0.28	0.4	1.15	2.35
PMS.00.250.CTCE30	31	23	0.28	0.4	1.65	3.0
PMS.00.250.CTCE31	31	23	0.46	0.55	1.65	3.0
PMS.00.250.CTCE35	31	23	0.46	0.55	1.65	3.35
PMS.00.250.CTCE44	31	23	0.28	0.4	2.65	4.35
PMS.00.250.CTCE52	34	26	0.90	0.97	3.05	5.2
PMS.00.250.CTCE56	34	26	0.90	0.97	3.05	5.45

Note: crimp contact

■ Collet Type

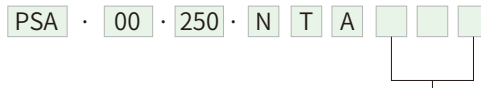

Variant _____

Bend relief for models with collet(letter Z in the variant position)

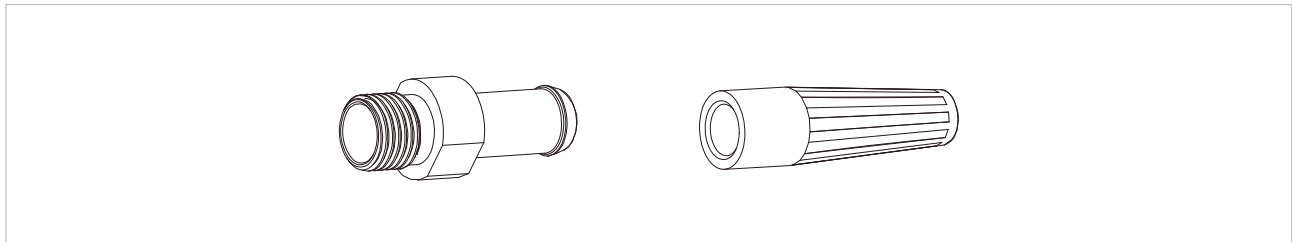

Reference	Need to be ordered separately(see page 161)
C15Z	SRA.00.0xx.G
C17Z	-
C22Z	SRA.00.0xx.G
C27Z	SRA.00.0xx.G
C31Z	SRA.0B.0xx.G
C52Z	SRA.0B.0xx.G
K37Z	SRA.0B.0xx.G
K42Z	SRA.0B.0xx.G
D42Z	SRA.0B.0xx.G
D52Z	SRA.00.0xx.G

Bend relief for models for cable crimping (no letter in the variant position)

The bend relief can be fitted directly over the crimp ferrule

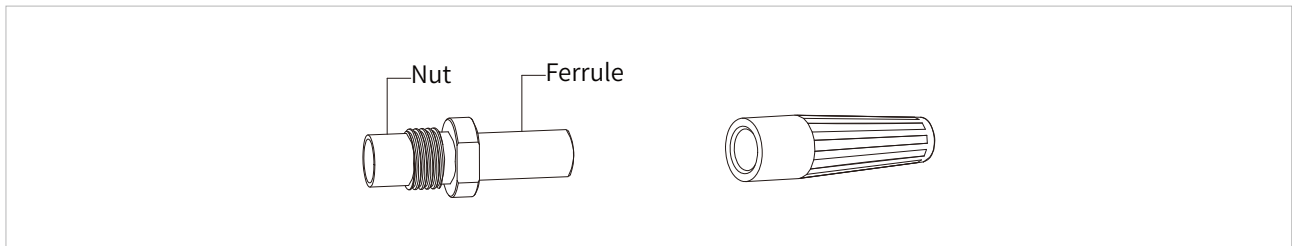

Reference	Need to be ordered separately(see page 161)
E24	SRA.00.0xx.G
E25	SRA.00.0xx.G
E30	SRA.00.0xx.G
E31	SRA.00.028.G
E32	SRA.00.0xx.G
E35	-
E44	-
E52	-
E56	-

E Series

Key Features:

- Security of the Push-Pull latching system
- Multipole types 2 to 10 contacts
- 360° screening for full EMC shielding
- Watertight connection (IP 68)
- Polarization by stepped insert (half-moon) fitted with male and female contacts
- Solder or print contacts (straight or angled)
- Rugged housing for extreme working condition



■ Part Number Definition

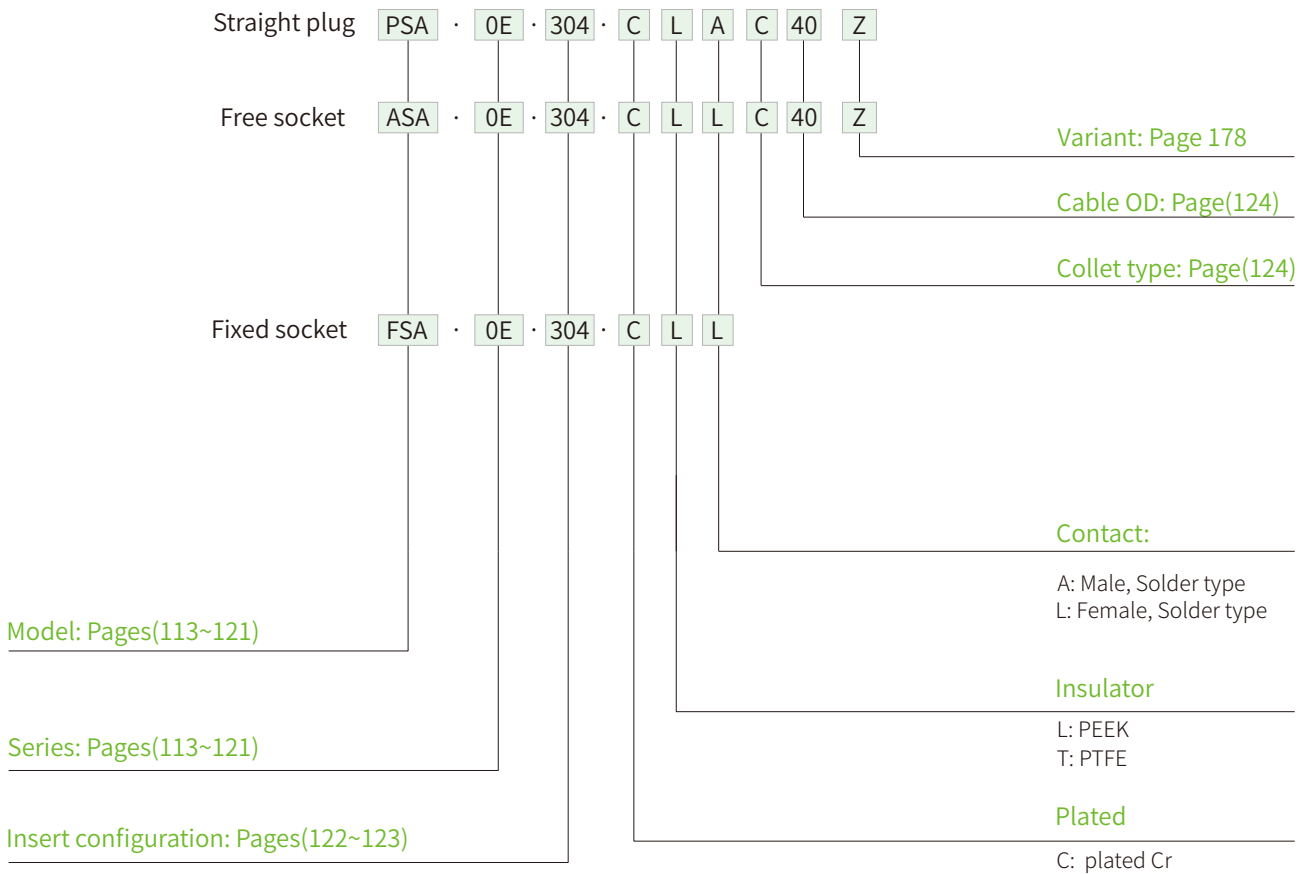

■ Part Number Example

Straight Plug With Cable Collet

PSA.0E.304.CLAC40= Straight plug with cable collet, 0E series, multipole type with 4 contacts, chrome-plated brass outershell, PEEK insulator, 2 male and 2 female solder contacts, C type collet for 4.0mm diameter cable.

Free Socket With Cable Collet

ASA.0E.304.CLLC40Z= Free socket with cable collet, 0E series, multipole type with 4 contacts, chrome-plated brass outershell, PEEK insulator, 2 female and 2 male solder contacts, C type collet for 4.0mm diameter cable and nut for fitting a bend relief.

Fixed Socket

FSA.0E.304.CLL= Fixed socket, nut fixing, 0E series, multipole type with 4 contacts, chrome-plated brass outershell, PEEK insulator, 2 female and 2 male solder contacts each end.

■ PSA Straight Plug, Cable Collet

- Connector series: PSA
- Contact: Hermaphroditic
- Locking type: Self-locking
- Orientation type: Straight
- Part No.: PSA.XE.XXX.CLACXX
- Mated with: FSA series

Note: "X" refers to part number definition on page 112

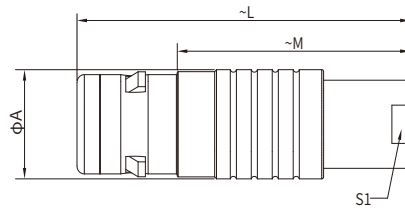

■ General Information

Ambient temperature:	-55°C ~ + 200°C	Seal/O-ring:	Silicone
Endurance:	>5000 cycles	Insulation resistance:	≥100MΩ
Insulator:	PEEK	IP rating:	IP68
Connector contacts:	Brass with gold plated	Shielding efficiency:	at 10MHz>95dB/at 1GHz>80dB
Housing:	Brass with Cr plated	Salt spray corrosion test:	>144h

Size	Dimensions(mm)			
	A	L	M	S1
0E	11	34	23	8
1E	13	42	28	9
2E	16	52	36	12

■ PPP Straight Plug, Non-latching, Cable Collet

- Connector series: PPP
- Contact: Hermaphroditic
- Locking type: Non-latching
- Orientation type: Straight
- Part No.: PPP.XE.XXX.CLACXX
- Mated with: FSA series

Note: "X" refers to part number definition on page 112

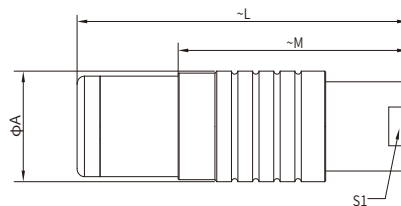

■ General Information

Ambient temperature:	-55°C ~ + 200°C	Seal/O-ring:	Silicone
Endurance:	>5000 cycles	Insulation resistance:	≥100MΩ
Insulator:	PEEK	IP rating:	IP68
Connector contacts:	Brass with gold plated	Shielding efficiency:	at 10MHz>95dB/at 1GHz>80dB
Housing:	Brass with Cr plated	Salt spray corrosion test:	>144h

Size	Dimensions(mm)			
	A	L	M	S1
0E	11	34	23	8
1E	13	42	28	9

POA Angled Plug, Cable Collet

- Connector series: POA
- Contact: Hermaphroditic
- Locking type: Self-locking
- Orientation type: Angled
- Part No.: POA.XE.XXX.CLACXX
- Mated with: FSA series

Note: "X" refers to part number definition on page 112

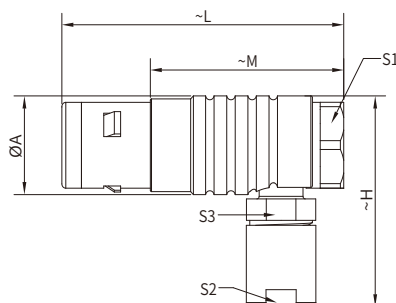

General Information

Ambient temperature:	-55°C~+200°C
Endurance:	>5000 cycles
Insulator:	PEEK
Housing:	Brass with Cr plated
Connector contacts:	Brass with gold plated

Insulation resistance:	≥100MΩ
IP rating:	IP68
Shielding efficiency:	at 10MHz>95dB/at 1GHz>80dB
Salt spray corrosion test:	>144h

Size	Dimensions(mm)						
	A	e	E	L	M	S1	S2
0E	18	M14*1.0	5.5	34	4.0	12.5	8
1E	20	M16*1.0	9.0	45	4.5	14.5	9
2E	25	M20*1.0	9.0	54	5.0	18.5	12

FSA Fixed Socket, Nut Fixing

- Connector series: FSA
- Contact: Hermaphroditic
- Locking type: Self-locking
- Orientation type: Straight
- Part No.: FSA.XE.XXX.CLL
- Mated with: PSA/POA/PPP series

Note: "X" refers to part number definition on page 112

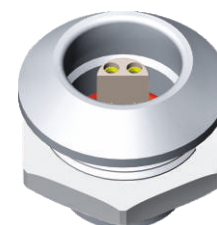
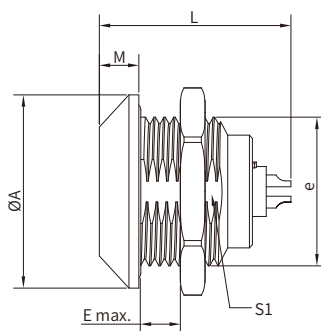

General Information

Ambient temperature:	-55°C ~ + 200°C
Endurance:	>5000 cycles
Insulator:	PEEK
Connector contacts:	Brass with gold plated
Coupling nut/screw:	Brass with nickel plated
Housing:	Brass with Cr plated

Seal/O-ring:	Silicone
Insulation resistance:	≥100MΩ
IP rating:	IP68
Shielding efficiency:	at 10MHz>95dB/at 1GHz>80dB
Salt spray corrosion test:	>144h

Size	Dimensions(mm)					
	A	e	E	L Max	M	S1
0E	18	M14*1.0	5.5	21.7	4.0	12.5
1E	20	M16*1.0	9.0	27.0	4.5	14.5
2E	25	M20*1.0	9.0	30.7	5.0	18.5

Note: Panel cut-out (page 180)

■ FNP Fixed Socket, Nut Fixing, Front Fasten

- Connector series: FNP
 - Contact: Hermaphroditic
 - Locking type: Self-locking
 - Orientation type: Straight
 - Part No.: FNP.XE.XXX.CLL
 - Mated with: PSA/POA/PPP series
- Note: "X" refers to part number definition on page 112

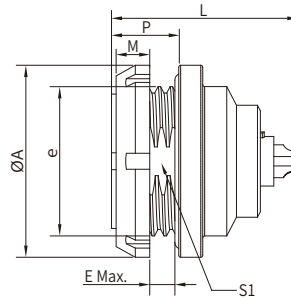

■ General Information

Ambient temperature:	-55°C ~ + 200°C
Endurance:	>5000 cycles
Insulator:	PEEK
Connector contacts:	Brass with gold plated
Coupling nut/screw:	Brass with Cr plated
Housing:	Brass with Cr plated

Seal/O-ring:	Silicone
Insulation resistance:	≥100MΩ
IP rating:	IP68
Shielding efficiency:	at 10MHz>95dB/at 1GHz>80dB
Salt spray corrosion test:	>144h

Size	Dimensions(mm)						
	A	e	E	L Max	M	P	S1
0E	18	M14*1.0	3.5	21.7	3.5	7.0	12.5
1E	20	M16*1.0	6.5	27.0	3.5	10.0	14.5
2E	25	M20*1.0	6.5	30.7	3.5	10.0	18.5

Note: Panel cut-out (page 180)

■ ASA Free Socket, Nut For Bend Relief

- Connector series: ASA
 - Contact: Hermaphroditic
 - Locking type: Self-locking
 - Orientation type: Straight
 - Part No.: ASA.XE.XXX.CLLCXXZ
 - Mated with: PSA/POA/PPP series
- Note: "X" refers to part number definition on page 112

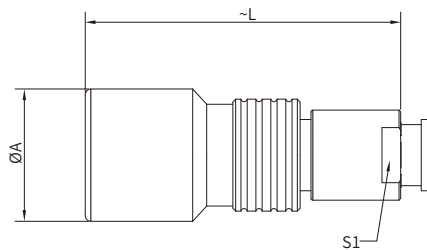

■ General Information

Ambient temperature:	-55°C ~ + 200°C
Endurance:	>5000 cycles
Insulator:	PEEK
Connector contacts:	Brass with gold plated
Housing:	Brass with Cr plated

Seal/O-ring:	Silicone
Insulation resistance:	≥100MΩ
IP rating:	IP68
Shielding efficiency:	at 10MHz>95dB/at 1GHz>80dB
Salt spray corrosion test:	>144h

Size	Dimensions(mm)		
	A	L	S1
0E	13	34	7
1E	15	45	9
2E	19	54	12

AMA Fixed Socket, Cable Collet

- Connector series: AMA
 - Contact: Hermaphroditic
 - Locking type: Self-locking
 - Orientation type: Straight
 - Part No.: AMA.XE.XXX.CLLCXX
 - Mated with: PSA/POA/PPP series
- Note: "X" refers to part number definition on page 112

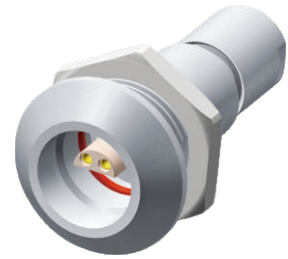
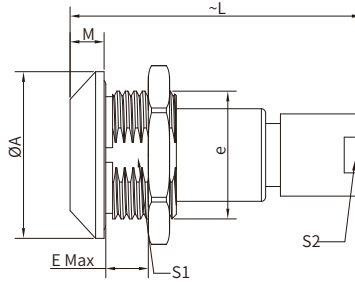

General Information

Ambient temperature:	-55°C ~ + 200°C
Endurance:	>5000 cycles
Insulator:	PEEK
Connector contacts:	Brass with gold plated
Housing:	Brass with Cr plated

Seal/O-ring:	Silicone
Insulation resistance:	≥100MΩ
IP rating:	IP68
Shielding efficiency:	at 10MHz>95dB/at 1GHz>80dB
Salt spray corrosion test:	>144h

Size	Dimensions(mm)						
	A	L	M	H	S1	S2	S3
0E	11.5	36	23	28.5	10	8	8
1E	14.0	43	28	35.5	12	9	10
2E	17.5	51	36	40.0	15	12	13

Note: Panel cut-out (page 180)

FLN Fixed Straight Socket, Rear Fastened

- Connector series: FLN
 - Contact: Female
 - Locking type: Self-locking
 - Orientation type: Straight
 - Part No.: FLN.xE.3xx.CLL
 - Mated with: PSA/POA/PPP
- Note: "X" refers to part number definition on page 112

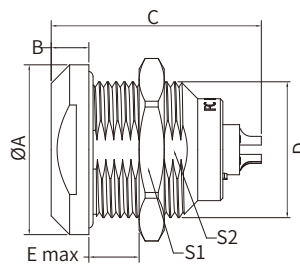

General Information

Ambient temperature:	-55°C ~ + 200°C
Endurance:	>5000 cycles
Insulator:	PEEK
Connector contacts:	Brass with gold plated
Coupling nut/screw:	Brass with nickel plated

Housing:	Brass with Cr plated
Insulator resistance:	≥100MΩ
IP rating:	IP 68
Salt spray corrosion test:	>144h
Shielding efficiency:	at 10MHz>95dB/at 1GHz>80dB

Size	Dimensions(mm)						
	A	B	C	D	E	S1	S2
0E	18	4.0	21.7	M14x1	5.5	17	12.5
1E	20	4.5	27.0	M16x1	9.0	19	14.5
2E	25	5.0	30.7	M20x1	9.0	24	18.5

Note: Panel cut-out (page 180)

■ FSA Fixed Straight Socket, 250 Coaxial, Rear Fastened

- Connector series: FSA
 - Contact: Female
 - Locking type: Self-locking
 - Orientation type: Straight
 - Part No.: FSA.1E.250.CTL
 - Mated with: PSA.1E.250.CLACxx(Z)
- Note: "X" refers to part number definition on page 112

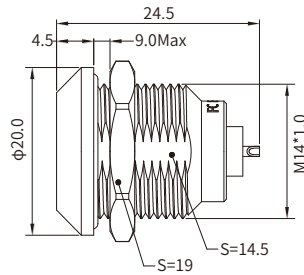

■ General information

Ambient temperature:	-55°C~+200°C	Rated current:	12A
Endurance:	>5000 cycles	VSWR:	1.01+0.23*f/GHz
Insulator:	PTFE	Insulator resistance:	≥100MΩ
Connector contacts:	Brass with gold plated	IP rating:	IP 68
Housing:	Brass with Cr plated	Shielding efficiency:	at 10MHz>95dB/at 1GHz>80dB
Impedance:	50Ω	Salt spray corrosion test:	>144h

■ FSA Fixed Straight Socket, Coaxial Triaxial, Rear Fastened

- Connector series: FSA
 - Contact: Female
 - Locking type: Self-locking
 - Orientation type: Straight
 - Part No.: FSA.1E.650.CTL
 - Mated with: PSA.1E.650.CLACxx(Z)
- Note: "X" refers to part number definition on page 112

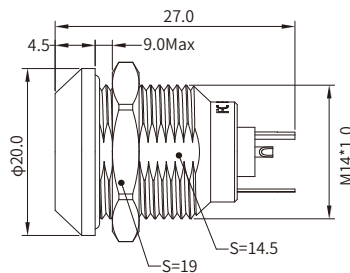

■ General information

Ambient temperature:	-55°C~+200°C	Rated current:	6A
Endurance:	>5000 cycles	VSWR:	1.01+0.17*f/GHz
Insulator:	PTFE	Insulator resistance:	≥100MΩ
Connector contacts:	Brass with gold plated	IP rating:	IP 68
Housing:	Brass with Cr plated	Shielding efficiency:	at 10MHz>95dB/at 1GHz>80dB
Impedance:	50Ω	Salt spray corrosion test:	>144h

FLN Fixed Straight Socket, 250 Coaxial, Rear Fastened

- Connector series: FLN
- Contact: Female
- Locking type: Self-locking
- Orientation type: Straight
- Part No.: FLN.1E.250.CTL
- Mated with: PSA.1E.250.CLACxx(Z)

Note: "X" refers to part number definition on page 112

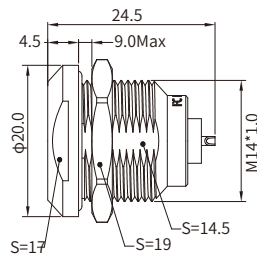

General information

Ambient temperature:	-55°C~+200°C
Endurance:	>5000 cycles
Insulator:	PTFE
Connector contacts:	Brass with gold plated
Housing:	Brass with Cr plated
Impedance:	50Ω

Rated current:	12A
VSWR:	1.01+0.23*f/GHz
Insulator resistance:	≥100MΩ
IP rating:	IP 68
Shielding efficiency:	at 10MHz>95dB/at 1GHz>80dB
Salt spray corrosion test:	>144h

FLN Fixed Straight Socket, Coaxial Triaxial, Rear Fastened

- Connector series: FLN
- Contact: Female
- Locking type: Self-locking
- Orientation type: Straight
- Part No.: FLN.1E.650.CTL
- Mated with: PSA.1E.650.CLACxx(Z)

Note: "X" refers to part number definition on page 112

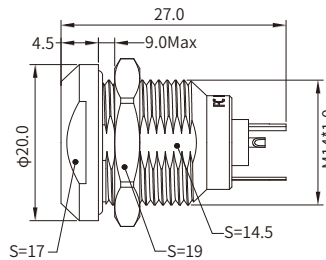

General information

Ambient temperature:	-55°C~+200°C
Endurance:	>5000 cycles
Insulator:	PTFE
Connector contacts:	Brass with gold plated
Housing:	Brass with Cr plated
Impedance:	50Ω

Rated current:	6A
VSWR:	1.01+0.17*f/GHz
Insulator resistance:	≥100MΩ
IP rating:	IP 68
Shielding efficiency:	at 10MHz>95dB/at 1GHz>80dB
Salt spray corrosion test:	>144h

PSA Straight Plug, Coaxial Triaxial, Cable Collet

- Connector series: PSA
- Contact: Male
- Locking type: Self-locking
- Orientation type: Straight
- Part No.: PSA.1E.650.CTACxx(Z)
- Mated with: FSA/FLN series

Note: "X" refers to part number definition on page 112

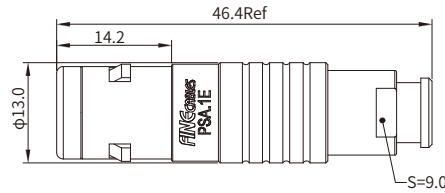

General information

Ambient temperature:	-55°C~+200°C	Rated current:	6A
Endurance:	>5000 cycles	VSWR:	1.01+0.17*f/GHz
Insulator:	PTFE	Insulator resistance:	≥100MΩ
Connector contacts:	Brass with gold plated	IP rating:	IP 68
Housing:	Brass with Cr plated	Shielding efficiency:	at 10MHz>95dB/at 1GHz>80dB
Impedance:	50Ω	Salt spray corrosion test:	>144h

PSA Straight Plug, 250 Coaxial, Cable Collet

- Connector series: PSA
- Contact: Male
- Locking type: Self-locking
- Orientation type: Straight
- Part No.: PSA.1E.250.CTACxx(Z)
- Mated with: FSA/FLN series

Note: "X" refers to part number definition on page 112

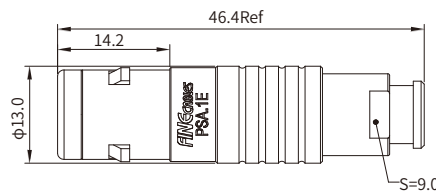

General information

Ambient temperature:	-55°C~+200°C	Rated current:	12A
Endurance:	>5000 cycles	VSWR:	1.01+0.23*f/GHz
Insulator:	PTFE	Insulator resistance:	≥100MΩ
Connector contacts:	Brass with gold plated	IP rating:	IP 68
Housing:	Brass with Cr plated	Shielding efficiency:	at 10MHz>95dB/at 1GHz>80dB
Impedance:	50Ω	Salt spray corrosion test:	>144h

■ CHG Plug Caps, Nut Fixing Or Flange

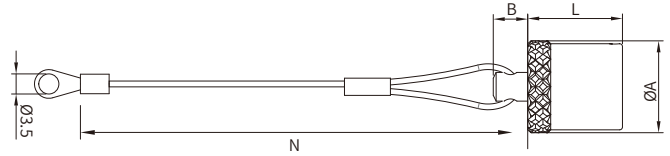

■ General Information

Ambient temperature:	Maximum 135°C
Endurance:	>5000 cycles
Body material	Nickel-plated brass
Lanyard materiel	Staninless steel

Crimp ferrule material:	Nickel-plated brass+polyolefin
O-ring material	Silicone rubber or FPM
IP rating:	IP 68
Salt spray corrosion test:	>144h

Part number	Size	Dimensions(mm)			
		A	B	L	N
CHG.0E.100.NAS	0E	14.0	6	12.5	85
CHG.1E.100.NAS	1E	16.0	6	15.5	85
CHG.2E.100.NAS	2E	19.5	6	17.5	85

Note: This cap is available only with an alignment key (G). The last letter "S" of part number stands for the material of the O-ring (silicone rubber). O-ring's made from FPM are also available; if required, replace the letter "S" by "V"

■ CRE Blanking Caps For Fixed Sockets

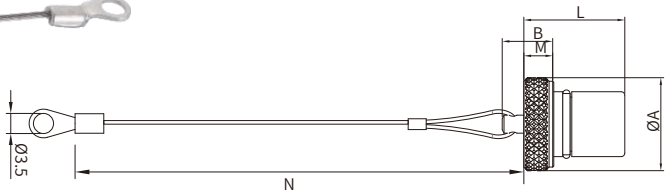

■ General Information

Ambient temperature:	Maximum 135°C
Endurance:	>5000 cycles
Body material	Nickel-plated brass
Lanyard materiel	Staninless steel

Crimp ferrule material:	Nickel-plated brass+polyolefin
O-ring material	Silicone rubber or FPM
IP rating:	IP 68
Salt spray corrosion test:	>144h

Part number	Size	Dimensions(mm)				
		A	B	L	M	N
CRE.0E.200.NAS	0E	15.0	10	15.0	4	85
CRE.1E.200.NAS	1E	17.0	12	20.0	6	85
CRE.2E.200.NAS	2E	20.5	14	24.0	8	85

Note: This caps are suitable for use with any alignment key configuration. The last letter "S" of part number stands for the material of the O-ring (silicone rubber). O-ring's made from FPM are also available; if required, replace the letter "S" by "V"

■ CFA Plug Caps, Sliding Loop

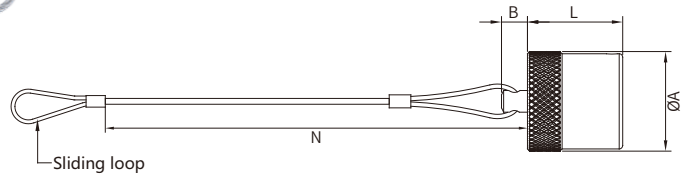

■ General Information

Ambient temperature:	maximum 135 °C
Endurance:	>5000 cycles
Body material:	Brass with nickel plated
Lanyard material:	Stainless steel

Crimp ferrule material:	Brass with nickel plated
O-ring material:	Silicone or FPM
Ip rating:	IP68
Salt spray corrosion test:	>144h

Part number	Size	Dimensions(mm)			
		A	B	L	N
CFA.0E.100.NAS	0E	14.0	6	12.5	85
CFA.1E.100.NAS	1E	16.0	6	15.5	85
CFA.2E.100.NAS	2E	19.5	6	17.5	85

Note: This cap is available only with an alignment key (G). The last letter "S" of part number stands for the material of the O-ring (silicone rubber). O-ring's made from FPM are also available; if required, replace the letter "S" by "V"

■ CRF Blanking Caps For Fixed Sockets, Sliding Loop

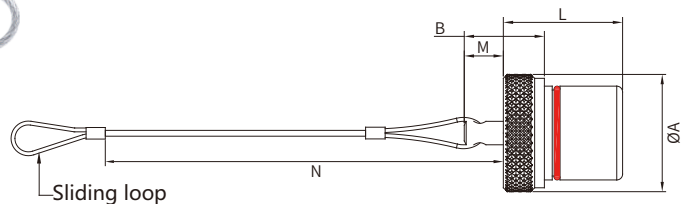

■ General Information

Ambient temperature:	maximum 135 °C
Endurance:	>5000 cycles
Body material:	Brass with nickel plated
Lanyard material:	Stainless steel

Crimp ferrule material:	Brass with nickel plated
O-ring material:	Silicone or FPM
Ip rating:	IP68
Salt spray corrosion test:	>144h

Part number	Size	Dimensions(mm)				
		A	B	L	M	N
CRF.0E.200.NAS	0E	15.0	10	15.0	4	85
CRF.1E.200.NAS	1E	17.0	12	20.0	6	85
CRF.2E.200.NAS	2E	20.5	14	24.0	8	85

Note: This cap is available only with an alignment key (G). The last letter "S" of part number stands for the material of the O-ring (silicone rubber). O-ring's made from FPM are also available; if required, replace the letter "S" by "V"

■ Electrical & Mechanical Data (Multipole)

PSA · 0E · 302 · C L A C 32 Z

Insert configuration

Size	Part.No	Pin Count	Pin layout From the direction of solder		Contact Dim (mm)	Rated current (A)	Contact type	Test voltage (KV rms)
			Male	Female				
0E	302	02			0.9	10	Solder	1.1
	303	03			0.7	7	Solder	1.0
	304	04			0.7	7	Solder	1.0
1E	302	02			1.3	15	Solder	1.2
	303	03			0.9	10	Solder	1.2
	304	04			0.9	10	Solder	1.2
	305	05			0.9 0.7	10 7	Solder	1.5 1.5
	306	06			0.7	7	Solder	1.2
2E	302	02			1.6	20	Solder	1.7
	303	03			1.3	15	Solder	1.5
	304	04			1.3	15	Solder	1.7
	305	05			1.3	13	Solder	1.5
	306	06			1.3	12	Solder	1.5
	307	07			1.3 0.9	12 9	Solder	0.8 0.8
	308	08			0.9	9	Solder	0.8
	310	10			0.9	7	Solder	0.8

It is proposed according to the following ratio : Operating Voltage (Us) = Test voltage(Ue) / 3

Caution:

For a number of applications, safety requirements for electrical appliances are more severe with regard to operating voltage. In such cases operating voltage is defined according to creepage distance and air clearance) between live parts.

■ Contact Type

PSA · 1E · 306 · C L A C 32 Z

Contacts reference for plugs free or fixed sockets

Contact type	Reference		Contact (mm)		Conductor Size					
					Solid		Stranded			
	Male	Female	Pin OD	Wire OD	AWG max.	Section max. (mm ²)	AWG		Section (mm ²)	
min.							max.	min.	max.	
Solder	A	L	0.7	0.60	24	0.25	-	26	-	0.14
			0.9	0.80	22	0.34	-	22	-	0.34
			1.3	1.00	20	0.50	-	20	-	0.50
			1.6	1.40	16	1.00	-	18	-	1.00
			2.0	1.80	14	1.50	-	16	-	1.50
			3.0	2.70	10	4.00	-	12	-	4.00
			4.0	3.70	10	6.00	-	10	-	6.00
			5.0	5.20	-	-	-	8	-	10.00
			6.0	5.20	-	-	-	8	-	10.00
			8.0	7.00	-	-	-	4	-	21.00
			12.0	11.50	-	-	-	0	-	50.00

■ Collet Type

PSA · OE · 302 · C L A C 42

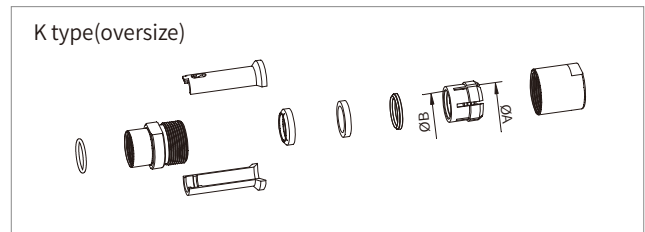
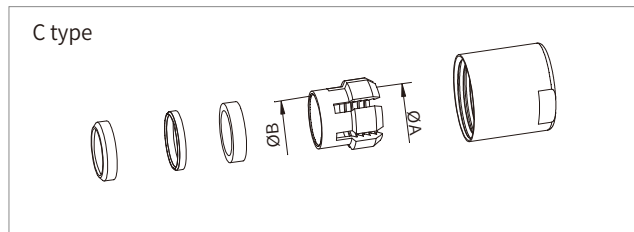
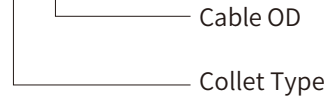

Series	Reference		Collet OD		Cable OD	
	Type	Code	A	B	max.	min.
OE	C	10	1.6	---	1.2	1.0
	C	15	1.6	---	1.5	1.3
	C	20	2.1	---	2.0	1.6
	C	25	3.1	---	2.5	2.1
	C	30	3.1	---	3.0	2.6
	C	35	4.2	4.2	3.5	3.1
	C	40	4.2	4.2	4.0	3.6
	C	45	5.2	5.2	4.5	4.1
1E	C	50	5.2	5.2	5.0	4.6
	C	15	1.6	---	1.5	1.3
	C	20	2.2	---	2.0	1.6
	C	25	3.2	---	2.5	2.1
	C	30	3.2	---	3.0	2.6
	C	35	4.2	---	3.5	3.1
	C	40	4.2	---	4.0	3.6
	C	45	5.2	---	4.5	4.1
	C	50	5.2	---	5.0	4.6
	C	55	6.2	6.2	5.5	5.1
	C	60	6.2	6.2	6.0	5.6
	C	65	7.2	6.7	6.5	6.1
	K	70	7.2	---	7.0	6.6
	K	75	8.2	8.2	7.5	7.1
K	80	8.2	8.2	8.0	7.6	
K	85	9.2	8.6	8.5	8.1	
2E	C	15	2.2	---	1.5	1.3
	C	20	2.2	---	2.0	1.6
	C	25	3.2	---	2.5	2.1
	C	30	3.2	---	3.0	2.6
	C	35	4.2	---	3.5	3.1
	C	40	4.2	---	4.0	3.6
	C	45	5.2	---	4.5	4.1
	C	50	5.2	---	5.0	4.6
	C	55	6.2	---	5.5	5.1
	C	60	6.2	---	6.0	5.6
	C	65	7.2	---	6.5	6.1
	C	70	7.2	---	7.0	6.6
	C	75	8.2	8.2	7.5	7.1
	C	80	8.2	8.2	8.0	7.6
	C	85	9.2	8.6	8.5	8.1
	K	90	9.2	---	9.0	8.6
	K	95	10.2	10.2	9.5	9.1
	K	10	10.2	10.2	10.0	9.6
	K	11	11.2	10.6	10.5	10.1

L Series

Key Features:

- Security of the Push-Pull latching system
- Multipole types 2 to 10 contacts
- 360° screening for full EMC shielding
- Watertight connection (IP 68)
- Polarization by stepped insert (half-moon) fitted with male and female contacts
- Solder or print contacts (straight or angled)
- Rugged housing for extreme working condition



■ Part Number Definition

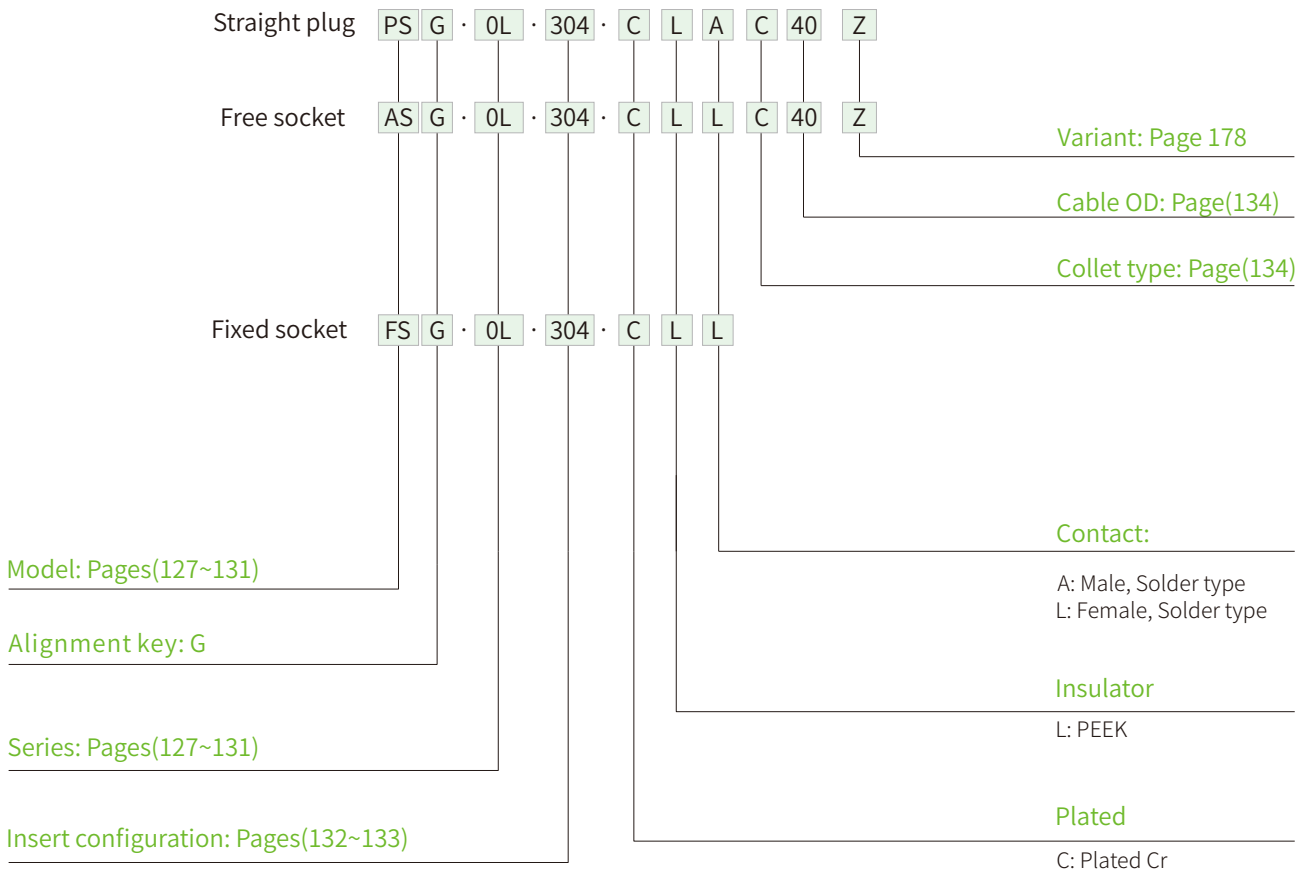

■ Part Number Example

Straight Plug With Cable Collet

PSG.0L.304.CLAC40= Straight plug with cable collet, G-key, 0L series, multipole type with 4 contacts, chrome-plated brass outershell, PEEK insulator, 2 male and 2 female solder contacts, C type collet for 4.0mm diameter cable.

Free Socket With Cable Collet

ASG.0L.304.CLLC40Z= Free socket with cable collet, G-key, 0L series, multipole type with 4 contacts, chrome-plated brass outershell, PEEK insulator, 2 female and 2 male solder contacts, C type collet for 4.0mm diameter cable and nut for fitting a bend relief.

Fixed Socket

FSG.0L.304.CLL= Fixed socket, nut fixing, G-key, 0L series, multipole type with 4 contacts, chrome-plated brass outershell, PEEK insulator, 2 female and 2 male solder contacts each end.

■ PSG Straight Plug, Key(G), Cable Collet

- Connector series: PSG
- Contact: Hermaphroditic
- Key: G
- Locking type: Self-locking
- Orientation type: Straight
- Part No.: PSG.XL.XXX.CLACXX
- Mated with: FSG/SRG series

Note: "X" refers to part number definition on page 126

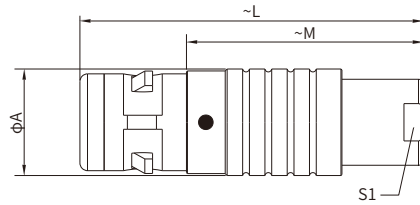

■ General Information

Ambient temperature:	-55°C ~ + 200°C	Seal/O-ring:	Silicone
Endurance:	>5000 cycles	Insulation resistance:	≥100MΩ
Insulator:	PEEK	IP rating:	IP68
Connector contacts:	Brass with gold plated	Shielding efficiency:	at 10MHz>95dB/at 1GHz>80dB
Housing:	Brass with Cr plated	Salt spray corrosion test:	>144h

Size	Dimensions(mm)			
	A	L	M	S1
0L	11	34	23	8
1L	13	42	28	9
2L	16	52	36	12

■ PAG Angled Plug, Key(G), Cable Collet

- Connector series: PAG
- Contact: Hermaphroditic
- Key: G
- Locking type: Self-locking
- Orientation type: Angled
- Part No.: PAG.XL.XXX.CLACXX
- Mated with: FSG/SRG series

Note: "X" refers to part number definition on page 126

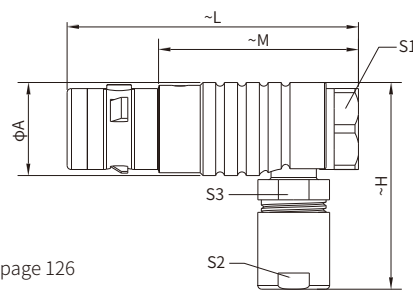

■ General Information

Ambient temperature:	-55°C ~ + 200°C	Seal/O-ring:	Silicone
Endurance:	>5000 cycles	Insulation resistance:	≥100MΩ
Insulator:	PEEK	IP rating:	IP68
Connector contacts:	Brass with gold plated	Shielding efficiency:	at 10MHz>95dB/at 1GHz>80dB
Housing:	Brass with Cr plated	Salt spray corrosion test:	>144h

Size	Dimensions(mm)						
	A	L	M	H	S1	S2	S3
0L	11.5	36	23	28.5	10	8	8
1L	14.0	43	28	35.5	12	9	10
2L	17.5	51	36	40.0	15	12	13

FSG Fixed Socket, Key(G), Nut Fixing

- Connector series: FSG
- Contact: Hermaphroditic
- Key: G
- Locking type: Self-locking
- Orientation type: Straight
- Part No.: FSG.XL.XXX.CLL
- Mated with: PSG/PAG series

Note: "X" refers to part number definition on page 126

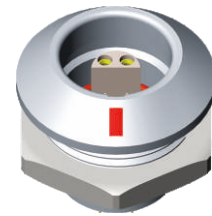
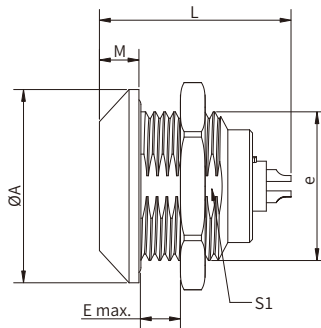

General Information

Ambient temperature:	-55°C ~ + 200°C
Endurance:	>5000 cycles
Insulator:	PEEK
Connector contacts:	Brass with gold plated
Coupling nut/screw:	Brass with nickel plated
Housing:	Brass with Cr plated

Seal/O-ring:	Silicone
Insulation resistance:	≥100MΩ
IP rating:	IP68
Shielding efficiency:	at 10MHz>95dB/at 1GHz>80dB
Salt spray corrosion test:	>144h

Size	Dimensions(mm)					
	A	e	E	L Max	M	S1
0L	18	M14*1.0	5.5	21.7	4.0	12.5
1L	20	M16*1.0	9.0	27.0	4.5	14.5
2L	25	M20*1.0	9.0	30.7	5.0	18.5

Note: Panel cut-out (page 180)

SRG Fixed Socket, Key(G), Nut Fixing, Front Fasten

- Connector series: SRG
- Contact: Hermaphroditic
- Key: G
- Locking type: Self-locking
- Orientation type: Straight
- Part No.: SRG.XL.XXX.CLL
- Mated with: PSG/PAG series

Note: "X" refers to part number definition on page 126

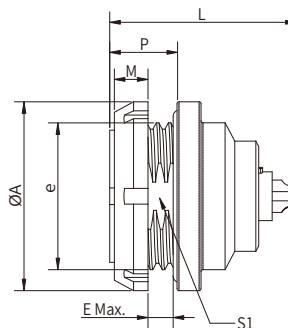

General Information

Ambient temperature:	-55°C ~ + 200°C
Endurance:	>5000 cycles
Insulator:	PEEK
Connector contacts:	Brass with gold plated
Coupling nut/screw:	Brass with Cr plated
Housing:	Brass with Cr plated

Seal/O-ring:	Silicone
Insulation resistance:	≥100MΩ
IP rating:	IP68
Shielding efficiency:	at 10MHz>95dB/at 1GHz>80dB
Salt spray corrosion test:	>144h

Size	Dimensions(mm)						
	A	e	E	L Max	M	P	S1
0L	18	M14*1.0	3.5	21.7	3.5	7.0	12.5
1L	20	M16*1.0	6.5	27.0	3.5	10.0	14.5
2L	25	M20*1.0	6.5	30.7	3.5	10.0	18.5

Note: Panel cut-out (page 180)

■ ASG Free Socket, Key(G), Nut For Bend Relief

- Connector series: ASG
- Contact: Hermaphroditic
- Key: G
- Locking type: Self-locking
- Orientation type: Straight
- Part No.: ASG.XL.XXX.CLXCXX
- Mated with: PSG/PAG series

Note: "X" refers to part number definition on page 126

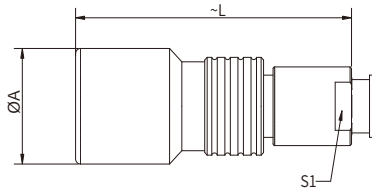

■ General Information

Ambient temperature:	-55°C ~ + 200°C	Seal/O-ring:	Silicone
Endurance:	>5000 cycles	Insulation resistance:	≥100MΩ
Insulator:	PEEK	IP rating:	IP68
Connector contacts:	Brass with gold plated	Shielding efficiency:	at 10MHz>95dB/at 1GHz>80dB
Housing:	Brass with Cr plated	Salt spray corrosion test:	>144h

Size	Dimensions(mm)		
	A	L	S1
0L	13	34	7
1L	15	45	9
2L	19	54	12

■ PRG Fixed Socket, Key(G), Cable Collet

- Connector series: PRG
- Contact: Hermaphroditic
- Key: G
- Locking type: Self-locking
- Orientation type: Straight
- Part No.: PRG.XL.XXX.CLXCXX
- Mated with: PSG/PAG series

Note: "X" refers to part number definition on page 126

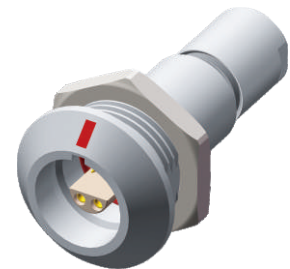
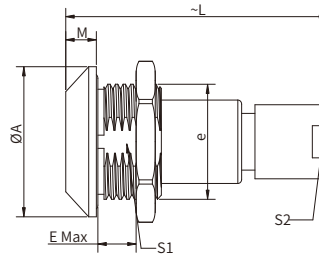

■ General Information

Ambient temperature:	-55°C ~ + 200°C	Seal/O-ring:	Silicone
Endurance:	>5000 cycles	Insulation resistance:	≥100MΩ
Insulator:	PEEK	IP rating:	IP68
Connector contacts:	Brass with gold plated	Shielding efficiency:	at 10MHz>95dB/at 1GHz>80dB
Coupling nut/screw:	Brass with nickel plated	Salt spray corrosion test:	>144h
Housing:	Brass with Cr plated		

Size	Dimensions(mm)						
	A	e	E	L	M	S1	S2
0L	18	M14*1.0	5.5	34	4.0	12.5	8
1L	20	M16*1.0	9.0	45	4.5	14.5	9
2L	25	M20*1.0	9.0	54	5.0	18.5	12

Note: Panel cut-out (page 180)

■ CHG Plug Caps, Nut Fixing Or Flange

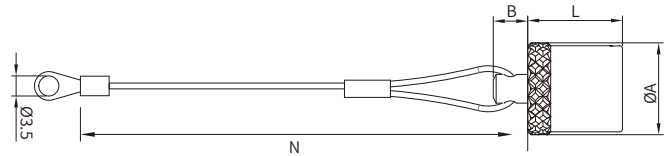

■ General Information

Ambient temperature:	Maximum 135°C
Endurance:	>5000 cycles
Body material	Nickel-plated brass
Lanyard materiel	Staninless steel

Crimp ferrule material:	Nickel-plated brass+polyolefin
O-ring material	Silicone rubber or FPM
IP rating:	IP 68
Salt spray corrosion test:	>144h

Part number	Size	Dimensions(mm)			
		A	B	L	N
CHG.0L.100.NAS	0L	14.0	6	12.5	85
CHG.1L.100.NAS	1L	16.0	6	15.5	85
CHG.2L.100.NAS	2L	19.5	6	17.5	85

Note: This cap is available only with an alignment key (G). The last letter "S" of part number stands for the material of the O-ring (silicone rubber). O-ring's made from FPM are also available; if required, replace the letter "S" by "V"

■ CRE Blanking Caps For Fixed Sockets

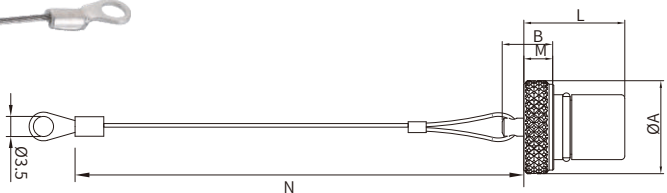

■ General Information

Ambient temperature:	Maximum 135°C
Endurance:	>5000 cycles
Body material	Nickel-plated brass
Lanyard materiel	Staninless steel

Crimp ferrule material:	Nickel-plated brass+polyolefin
O-ring material	Silicone rubber or FPM
IP rating:	IP 68
Salt spray corrosion test:	>144h

Part number	Size	Dimensions(mm)				
		A	B	L	M	N
CRE.0L.200.NAS	0L	15.0	10	15.0	4	85
CRE.1L.200.NAS	1L	17.0	12	20.0	6	85
CRE.2L.200.NAS	2L	20.5	14	24.0	8	85

Note: This caps are suitable for use with any alignment key configuration. The last letter "S" of part number stands for the material of the O-ring (silicone rubber). O-ring's made from FPM are also available; if required, replace the letter "S" by "V"

■ CFA Plug Caps, Sliding Loop

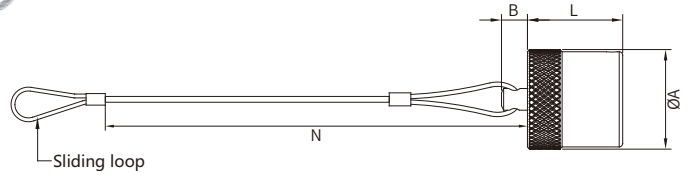

■ General Information

Ambient temperature:	maximum 135 °C
Endurance:	>5000 cycles
Body material:	Brass with nickel plated
Lanyard material:	Stainless steel

Crimp ferrule material:	Brass with nickel plated
O-ring material:	Silicone or FPM
Ip rating:	IP68
Salt spray corrosion test:	>144h

Part number	Size	Dimensions(mm)			
		A	B	L	N
CFA.0L.100.NAS	0L	14.0	6	12.5	85
CFA.1L.100.NAS	1L	16.0	6	15.5	85
CFA.2L.100.NAS	2L	19.5	6	17.5	85

Note: This cap is available only with an alignment key (G). The last letter "S" of part number stands for the material of the O-ring (silicone rubber). O-ring's made from FPM are also available; if required, replace the letter "S" by "V"

■ CRF Blanking Caps For Fixed Sockets, Sliding Loop

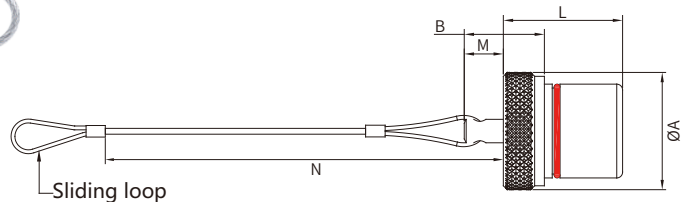

■ General Information

Ambient temperature:	maximum 135 °C
Endurance:	>5000 cycles
Body material:	Brass with nickel plated
Lanyard material:	Stainless steel

Crimp ferrule material:	Brass with nickel plated
O-ring material:	Silicone or FPM
Ip rating:	IP68
Salt spray corrosion test:	>144h

Part number	Size	Dimensions(mm)				
		A	B	L	M	N
CRF.0L.200.NAS	0L	15.0	10	15.0	4	85
CRF.1L.200.NAS	1L	17.0	12	20.0	6	85
CRF.2L.200.NAS	2L	20.5	14	24.0	8	85

Note: This cap is available only with an alignment key (G). The last letter "S" of part number stands for the material of the O-ring (silicone rubber). O-ring's made from FPM are also available; if required, replace the letter "S" by "V"

■ Electrical & Mechanical Data (Multipole)

PSG · 0L · 304 · C L A C 40 Z

Insert configuration

Size	Part.No	Pin Count	Pin layout From the direction of solder		Contact Dim (mm)	Rated current (A)	Contact type	Test voltage (KV rms)
			Male	Female				
0L	302	02			0.9	10	Solder	1.1
	303	03			0.7	7	Solder	1.0
	304	04			0.7	7	Solder	1.0
1L	302	02			1.3	15	Solder	1.2
	303	03			0.9	10	Solder	1.2
	304	04			0.9	10	Solder	1.2
	305	05			0.9 0.7	10 7	Solder	1.5 1.5
	306	06			0.7	7	Solder	1.2
2L	302	02			1.6	20	Solder	1.7
	303	03			1.3	15	Solder	1.5
	304	04			1.3	15	Solder	1.7
	305	05			1.3	13	Solder	1.5
	306	06			1.3	12	Solder	1.5
	307	07			1.3 0.9	12 9	Solder	0.8 0.8
	308	08			0.9	9	Solder	0.8
	310	10			0.9	7	Solder	0.8

It is proposed according to the following ratio : Operating Voltage (Us) = Test voltage(Ue) / 3

Caution:

For a number of applications, safety requirements for electrical appliances are more severe with regard to operating voltage. In such cases operating voltage is defined according to creepage distance and air clearance) between live parts.

■ Contact Type

PSA · 1L · 306 · C L A C 32 Z

Contacts reference for plugs free or fixed sockets

Contact type	Reference		Contact (mm)		Conductor Size					
					Solid		Stranded			
	Male	Female	Pin OD	Wire OD	AWG max.	Section max. (mm ²)	AWG		Section (mm ²)	
						min.	max.	min.	max.	
Solder	A	L	0.7	0.60	24	0.25	-	26	-	0.14
			0.9	0.80	22	0.34	-	22	-	0.34
			1.3	1.00	20	0.50	-	20	-	0.50
			1.6	1.40	16	1.00	-	18	-	1.00
			2.0	1.80	14	1.50	-	16	-	1.50
			3.0	2.70	10	4.00	-	12	-	4.00
			4.0	3.70	10	6.00	-	10	-	6.00
			5.0	5.20	-	-	-	8	-	10.00
			6.0	5.20	-	-	-	8	-	10.00
			8.0	7.00	-	-	-	4	-	21.00
			12.0	11.50	-	-	-	0	-	50.00

■ Collet Type

PSG · OL · 302 · C L A C 42

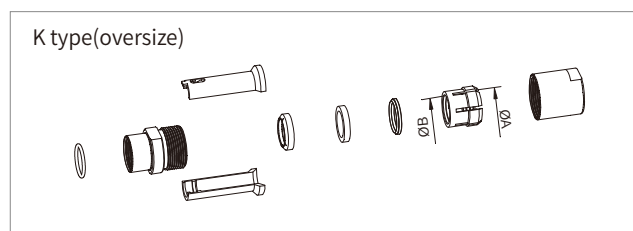
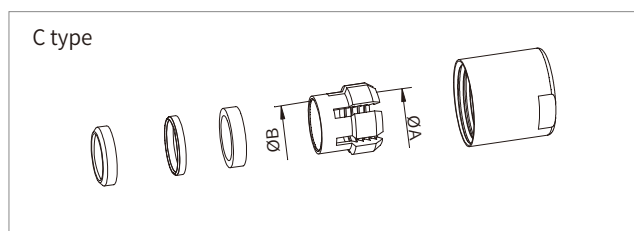
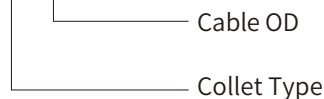

Series	Reference		Collet OD		Cable OD	
	Type	Code	A	B	max.	min.
0L	C	10	1.6	---	1.2	1.0
	C	15	1.6	---	1.5	1.3
	C	20	2.1	---	2.0	1.6
	C	25	3.1	---	2.5	2.1
	C	30	3.1	---	3.0	2.6
	C	35	4.2	4.2	3.5	3.1
	C	40	4.2	4.2	4.0	3.6
	C	45	5.2	5.2	4.5	4.1
1L	C	50	5.2	5.2	5.0	4.6
	C	15	1.6	---	1.5	1.3
	C	20	2.2	---	2.0	1.6
	C	25	3.2	---	2.5	2.1
	C	30	3.2	---	3.0	2.6
	C	35	4.2	---	3.5	3.1
	C	40	4.2	---	4.0	3.6
	C	45	5.2	---	4.5	4.1
	C	50	5.2	---	5.0	4.6
	C	55	6.2	6.2	5.5	5.1
	C	60	6.2	6.2	6.0	5.6
	C	65	7.2	6.7	6.5	6.1
	K	70	7.2	---	7.0	6.6
	K	75	8.2	8.2	7.5	7.1
K	80	8.2	8.2	8.0	7.6	
K	85	9.2	8.6	8.5	8.1	
2L	C	15	2.2	---	1.5	1.3
	C	20	2.2	---	2.0	1.6
	C	25	3.2	---	2.5	2.1
	C	30	3.2	---	3.0	2.6
	C	35	4.2	---	3.5	3.1
	C	40	4.2	---	4.0	3.6
	C	45	5.2	---	4.5	4.1
	C	50	5.2	---	5.0	4.6
	C	55	6.2	---	5.5	5.1
	C	60	6.2	---	6.0	5.6
	C	65	7.2	---	6.5	6.1
	C	70	7.2	---	7.0	6.6
	C	75	8.2	8.2	7.5	7.1
	C	80	8.2	8.2	8.0	7.6
	C	85	9.2	8.6	8.5	8.1
	K	90	9.2	---	9.0	8.6
	K	95	10.2	10.2	9.5	9.1
	K	10	10.2	10.2	10.0	9.6
	K	11	11.2	10.6	10.5	10.1

Q Series

Key Features:

- Quick locking system
- Vibration-proof and reliable connection
- 360° screening for full EMC shielding
- Excellent vibration resistance
- Watertight connection (IP68)
- Strong Mating endurance: >10,000 cycles



■ Part Number Definition

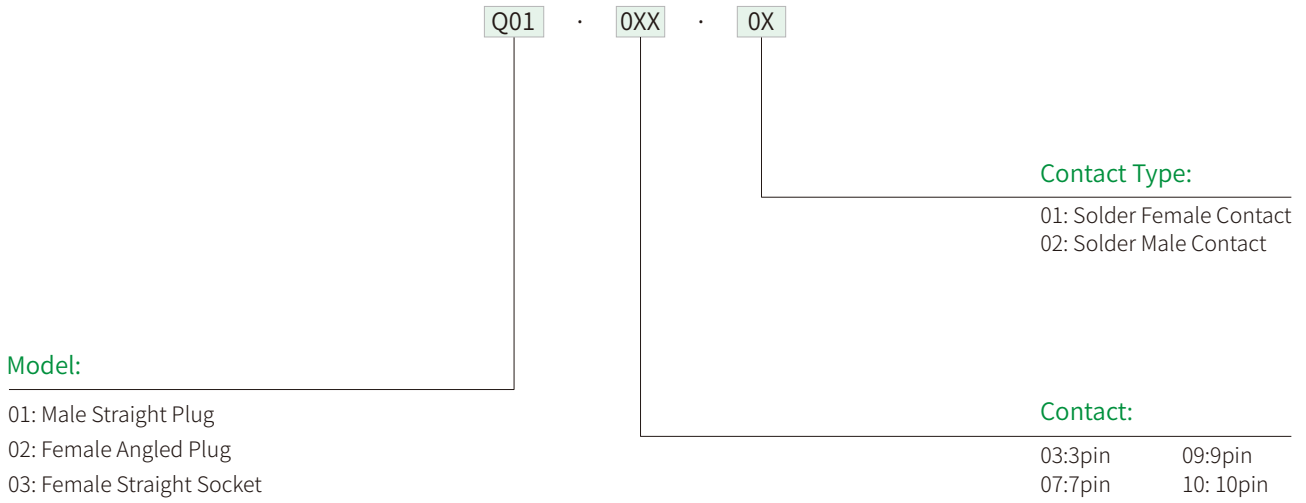

■ Part Number Example

Straight/ Angled Male Plug

Q01.003.01=Q Series, Male Straight Plug, 3 contacts, Solder Male Contact; Q02.007.01=Q Series, Female Angled Plug, 7 contacts, Solder Male Contact

Straight Female Socket

Q03.009.02=Q Series, Female Straight Socket, 9 contacts, Solder Female Contact

Q01 Straight Plug

- Connector series: Q01.0XX.02
- Contact: Male
- Locking type: Self-Locking
- Orientation type: Straight
- Part No.: Q01.0XX.02
- Mated with: Q03.0XX.01

Note: "X" refers to part number definition on page 136

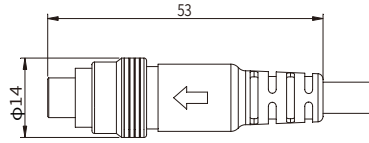

General Information

Ambient temperature:	-20°C ~ + 80°C
Endurance:	> 10000 cycles
Insulator:	PEEK
Connector contacts:	Brass with gold plated
Out shell:	Brass with Black nickel plated

Insulator resistance:	≥ 100MΩ
IP rating:	IP 68
Shielding efficiency:	at 10MHz>75dB/at 1GHz>40dB
Salt spray corrosion test:	>96h

Q02 Angle Plug

- Connector series: Q02.0XX.02
- Contact: Male
- Locking type: Self-Locking
- Orientation type: Angle
- Part No.: Q02.0XX.02
- Mated with: Q03.0XX.01

Note: "X" refers to part number definition on page 136

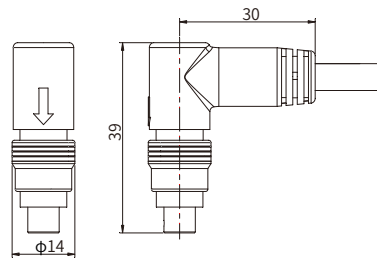

General Information

Ambient temperature:	-20°C ~ + 80°C
Endurance:	> 10000 cycles
Insulator:	PEEK
Connector contacts:	Brass with gold plated
Out shell:	Brass with Black nickel plated

Insulator resistance:	≥ 100MΩ
IP rating:	IP 68
Shielding efficiency:	at 10MHz>75dB/at 1GHz>40dB
Salt spray corrosion test:	>96h

Q03 Straight Socket

- Connector series: Q03.0XX.01
- Contact: Female
- Locking type: Self-Locking
- Orientation type: Straight
- Part No.: Q03.0XX.01
- Mated with: Q01.0XX.02/Q02.0XX.02

Note: "X" refers to part number definition on page 136

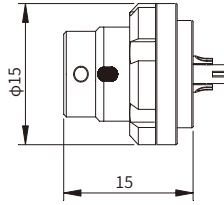

General Information

Ambient temperature:	-20°C ~ + 80°C
Endurance:	>10000 cycles
Insulator:	PEEK
Connector contacts:	Brass with gold plated
Out shell:	Brass with Black nickel plated

Insulator resistance:	$\geq 100M\Omega$
IP rating:	IP 68
Shielding efficiency:	at 10MHz>75dB/at 1GHz>40dB
Salt spray corrosion test:	>96h

Q04 Straight Plug

- Connector series: Q04.0XX.02
- Contact: Male
- Locking type: Self-Locking
- Orientation type: Straight
- Part No.: Q04.0XX.02
- Mated with: Q03.0XX.01

Note: "X" refers to part number definition on page 136

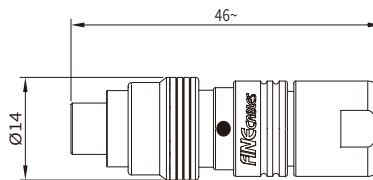

General Information

Ambient temperature:	-20°C ~ + 80°C
Endurance:	>10000 cycles
Insulator:	PEEK
Connector contacts:	Brass with gold plated
Out shell:	Brass with Black nickel plated

Insulator resistance:	$\geq 100M\Omega$
IP rating:	IP 68
Shielding efficiency:	at 10MHz>75dB/at 1GHz>40dB
Salt spray corrosion test:	>96h

■ Electrical & Mechanical Data

Q01 · 0XX · 0X

Insert configuration

Size	Part.No	Pin Count	Pin layout From the direction of solder		Contact Dim (mm)	Rated current (A)	Color identification	Contact type			Test voltage(KV rms)			
			Male	Female				Solder	Print	Crimp	Solder contact		Crimp contact	
											Contact and Contact	Contact and Shell	Contact and Contact	Contact and Shell
Q01 & Q02 & Q03	003	03			0.90	5	Red	●	-	-	1.00	0.8	-	-
	007	07			0.50	2	Silver	●	-	-	0.80	0.7	-	-
	009	09			0.50	1.5	Blue	●	-	-	0.60	0.5	-	-
	010	10			0.50	1.0	Black	●	-	-	0.45	0.5	-	-

● First Recommendation ○ Special order alternative

R Series

Key Features:

This series is a customized product, The push-pull latching system has been replaced by a screw coupling. The insulation is used as same as the B/K series. After cable assembly, the rear part must be filled with resin in order to ensure the waterproofing of the cable.

- Screw locking system
- 360° screening for full EMC shielding
- Vibration-proof and reliable connection
- Watertight connection (IP67)



■ Part Number Definition

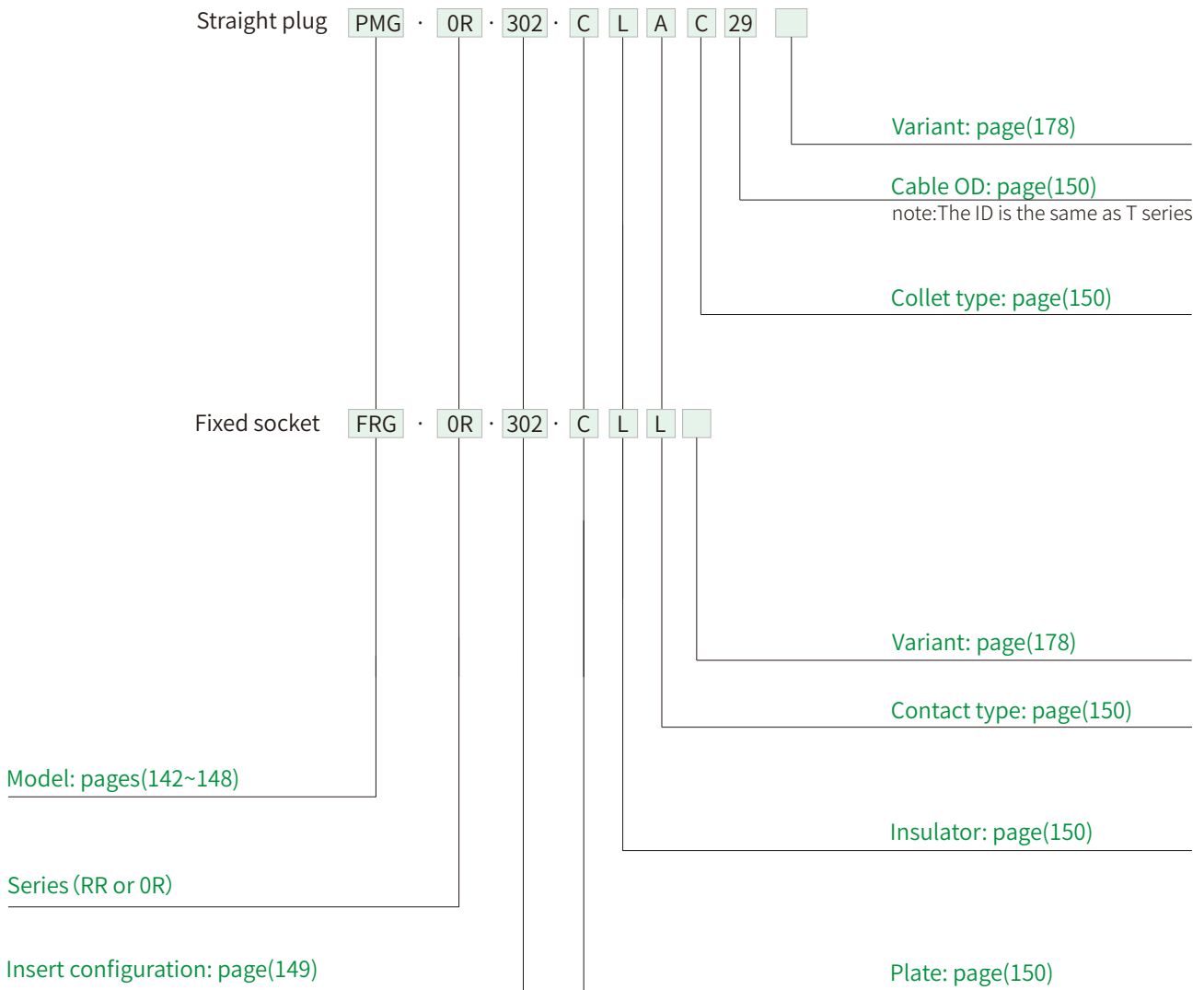

■ Part Number Example

Straight plug and nut for bend relief

PMG.RR.302.CLAC29 = Customized product;straight plug with cable collet and screw locking, series RR, 2pin, outer shell in Cr-plated brass,PEEK insulator, male solder contact, C type collet of 2.9 mm diameter.

R Series, Angled Plug, Molding With Cable

- Connector series: PAM
- Contact: Male
- Locking type: Self-locking
- Orientation type: Angled
- Part No.: PAM.0R.XXX.KLAXX
- Mated with: FSM.0R.XXX.KLL

Note: "X" refers to part number definition on page 141

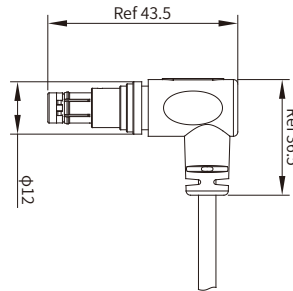

General Information

Ambient temperature:	-20 °C ~ + 80 °C
Endurance:	≥3000 cycles
Insulator:	PEEK
Connector contacts:	Brass with gold plated
Housing:	Brass with black Cr plated

Insulator resistance:	≥100MΩ
IP rating:	IP 67
Shielding efficiency:	at10MHZ>75dB/at 1GHZ>40dB
Salt spray corrosion test:	>144h

R Series, Angled Plug, Molding With Cable, Short Version

- Connector series: PAN
- Contact: Male
- Locking type: Self-locking
- Orientation type: Angled
- Part No.: PAN.0R.XXX.KLAXX
- Mated with: FSM.0R.XXX.KLL

Note: "X" refers to part number definition on page 141

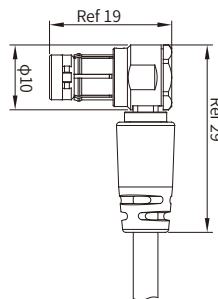

General Information

Ambient temperature:	-20 °C ~ + 80 °C
Endurance:	≥3000 cycles
Insulator:	PEEK
Connector contacts:	Brass with gold plated
Housing:	Brass with black Cr plated

Insulator resistance:	≥100MΩ
IP rating:	IP 67
Shielding efficiency:	at10MHZ>75dB/at 1GHZ>40dB
Salt spray corrosion test:	>144h

PMG Straight Plug With Cable, Threaded Joint

- Connector series: PMG
- Contact: Male
- Locking type: Screw Locking
- Orientation type: Straight
- Part No.: PMG.0R.XXX.CLACXX
- Mated with: SRG.0R.XXX.CLL

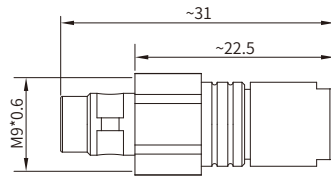

Note: "X" refers to part number definition on page 141

General Information

Ambient temperature:	-20°C ~ + 80°C
Endurance:	≥3000 cycles
Insulator:	PEEK
Connector contacts:	Brass with gold plated
Coupling nut/screw:	Brass with Cr plated

Housing:	Brass with Cr plated
Insulator resistance:	≥100MΩ
IP rating:	IP 68
Shielding efficiency:	at 10MHz>75dB/at 1GHz>40dB
Salt spray corrosion test:	>144h

SRG Fixed Straight Socket, Threaded Joint

- Connector series: SRG
- Contact: Female
- Locking type: Screw Locking
- Orientation type: Straight
- Part No.: SRG.0R.XXX.CLL
- Mated with: PMG.0R.XXX.CLACXX

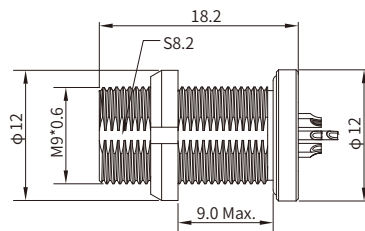

Note: "X" refers to part number definition on page 141

General Information

Ambient temperature:	-20°C ~ + 80°C
Endurance:	≥3000 cycles
Insulator:	PEEK
Connector contacts:	Brass with gold plated
Coupling nut/screw:	Brass with Cr plated

Housing:	Brass with Cr plated
Insulator resistance:	≥100MΩ
IP rating:	IP 68
Shielding efficiency:	at 10MHz>75dB/at 1GHz>40dB
Salt spray corrosion test:	>144h

Note: Panel cut-out (page 180)

■ PSG Straight Plug, Cable Collet (Three Keys)

- Connector series: PSG
- Contact: Male
- Locking type: Self-locking
- Orientation type: Straight
- Part No.: PSG.0R.XXX.KLACXXZ
- Mated with: FRG.0R.XXX.KLL

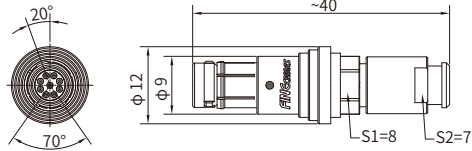

Note: "X" refers to part number definition on page 141

■ General Information

Ambient temperature:	-20°C ~ + 80°C
Endurance:	≥3000 cycles
Insulator:	PEEK
Connector contacts:	Brass with gold plated
Coupling nut/screw:	Brass with black Cr plated

Housing:	Brass with black Cr plated
Insulator resistance:	≥100MΩ
IP rating:	IP 68
Shielding efficiency:	at 10MHz>75dB/at 1GHz>40dB
Salt spray corrosion test:	>144h

■ FRG Fixed Socket With Earthing Tag, Front Fasten (Three Keys)

- Connector series: FRG
- Contact: Female
- Locking type: Self-locking
- Orientation type: Straight
- Part No.: FRG.0R.XXX.KLL
- Mated with: PSG.0R.XXX.KLACXXZ

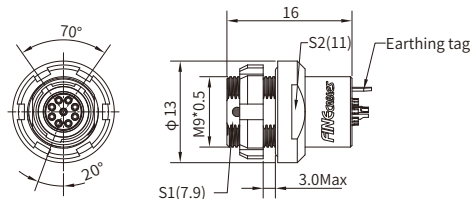

Note: "X" refers to part number definition on page 141

■ General Information

Ambient temperature:	-20°C ~ + 80°C
Endurance:	≥3000 cycles
Insulator:	PEEK
Connector contacts:	Brass with gold plated
Coupling nut/screw:	Brass with black Cr plated

Housing:	Brass with black Cr plated
Insulator resistance:	≥100MΩ
IP rating:	IP 68
Shielding efficiency:	at 10MHz>75dB/at 1GHz>40dB
Salt spray corrosion test:	>144h

Note: Panel cut-out (page 180)

PSN Straight Plug, Cable Collet(Two Keys)

- Connector series: PSN
- Contact: Male
- Locking type: Self-locking
- Orientation type: Straight
- Part No.: PSN.0R.XXX.KLACXXZ
- Mated with: FRN.0R.XXX.KLL

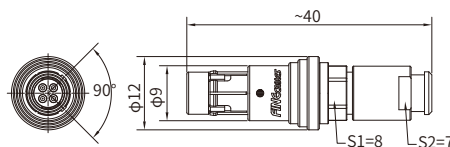

Note: "X" refers to part number definition on page 141

General Information

Ambient temperature:	-20°C ~ + 80°C
Endurance:	≥3000 cycles
Insulator:	PEEK
Connector contacts:	Brass with gold plated
Coupling nut/screw:	Brass with black Cr plated

Housing:	Brass with black Cr plated
Insulator resistance:	≥100MΩ
IP rating:	IP 68
Shielding efficiency:	at 10MHz>75dB/at 1GHz>40dB
Salt spray corrosion test:	>144h

FRN Fixed Socket With Earthing Tag, Front Fasten (Two Keys)

- Connector series: FRN
- Contact: Female
- Locking type: Self-locking
- Orientation type: Straight
- Part No.: FRN.0R.XXX.KLL
- Mated with: PSN.0R.XXX.KLACXXZ

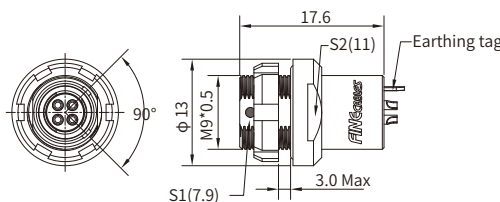

Note: "X" refers to part number definition on page 141

General Information

Ambient temperature:	-20°C ~ + 80°C
Endurance:	≥3000 cycles
Insulator:	PEEK
Connector contacts:	Brass with gold plated
Coupling nut/screw:	Brass with black Cr plated

Housing:	Brass with black Cr plated
Insulator resistance:	≥100MΩ
IP rating:	IP 68
Shielding efficiency:	at 10MHz>75dB/at 1GHz>40dB
Salt spray corrosion test:	>144h

Note: Panel cut-out (page 180)

■ PMG Straight Plug, Key(G), Cable Collet

- Connector series: PMG
- Contact: Male
- Locking type: Screw Locking
- Orientation type: Plug
- Part No.: PMG.RR.3xx.CLACxx
- Mated with: SRG

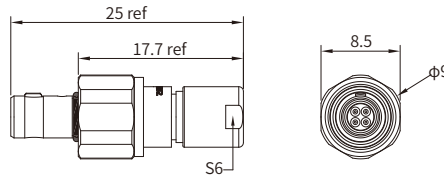

Note: "X" refers to part number definition on page 141

■ General Information

Ambient temperature:	-20°C ~ + 80°C
Endurance:	> 3000 cycles
Insulator:	PEEK
Connector contacts:	Brass with gold plated
Housing:	Brass with Cr plated

O-ring:	FPM
Insulator resistance:	≥ 100MΩ
IP rating:	IP 68
Shielding efficiency:	at 10MHz>75dB/at 1GHz>40dB
Salt spray corrosion test:	>144h

■ SRG Fixed Socket, Key(G), Nut Fixing, Resin Sealing

- Connector series: SRG
- Contact: Female
- Locking type: Screw Locking
- Orientation type: Socket
- Part No.: SRG.RR.3xx.CLL
- Mated with: PMG

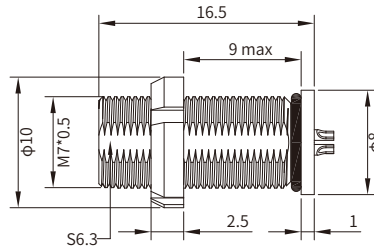

Note: "X" refers to part number definition on page 141

■ General Information

Ambient temperature:	-20°C ~ + 80°C
Endurance:	> 3000 cycles
Insulator:	PEEK
Connector contacts:	Brass with gold plated
Housing:	Brass with Cr plated

O-ring:	Silicone
Insulator resistance:	≥ 100MΩ
IP rating:	IP 68
Shielding efficiency:	at 10MHz>75dB/at 1GHz>40dB
Salt spray corrosion test:	>144h

Note: Epoxy resin is used to seal these models Panel cut-out (page 180)

■ PSA Straight Plug , Cable Collet (One Key)

- Connector series: PSA
- Contact: Male
- Locking type: Self-locking
- Orientation type: Straight
- Part No.: PSA.0R.XXX.CLACXXZ
- Mated with: FSA.0R.XXX.CLV

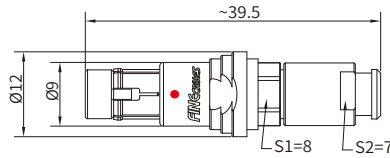

Note: "X" refers to part number definition on page 141

■ General Information

Ambient temperature:	-20°C ~ + 80°C	Housing:	Brass with Cr plated
Endurance:	≥3000 cycles	Insulator resistance:	≥100MΩ
Insulator:	PEEK	IP rating:	IP 68
Connector contacts:	Brass with gold plated	Shielding efficiency:	at 10MHz>75dB/at 1GHz>40dB
Coupling nut/screw:	Brass with Cr plated	Salt spray corrosion test:	>144h

■ FSA Fixed Socket With Elbow Terminals For Printed Circuit, Front Fasten (One Key)

- Connector series: FSA
- Contact: Female
- Locking type: Self-locking
- Orientation type: Angled
- Part No.: FSA.0R.XXX.CLV
- Mated with: PSA.0R.XXX.CLACXXZ

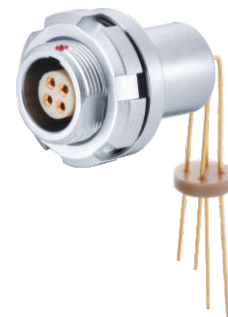
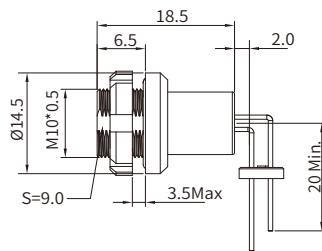

Note: "X" refers to part number definition on page 141

■ General Information

Ambient temperature:	-20°C ~ + 80°C	Housing:	Brass with black Cr plated
Endurance:	≥3000 cycles	Insulator resistance:	≥100MΩ
Insulator:	PEEK	IP rating:	IP 68
Connector contacts:	Brass with gold plated	Shielding efficiency:	at 10MHz>75dB/at 1GHz>40dB
Coupling nut/screw:	Brass with Cr plated	Salt spray corrosion test:	>144h

R Series, Fixed Socket, Front Fasten(Three keys)

- Connector series: FSM
- Contact: Female
- Locking type: Self-locking
- Orientation type: Straight
- Part No.: FSM.0R.XXX.KLL
- Mated with: PAM/PAN.0R.XXX.KLL

Note: "X" refers to part number definition on page 141

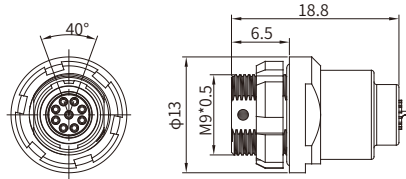

General Information

Ambient temperature:	-20 °C ~ + 80 °C
Endurance:	≥3000 cycles
Insulator:	PEEK
Connector contacts:	Brass with gold plated
Coupling nut /screw:	Brass with black Cr plated

Housing:	Brass with black Cr plated
Insulator resistance:	≥100MΩ
IP rating:	IP 67
Shielding efficiency:	at10MHZ>75dB/at 1GHZ>40dB
Salt spray corrosion test:	>144h

■ Electrical & Mechanical Data

PMG · OR · 302 · C L A C 29

Insert configuration

Size	Part.No	Pin Count	Pin layout From the direction of solder		Contact Dim (mm)	Rated current (A)	Contact type			Test voltage(KV rms)			
			Male	Female			Solder	Print	Crimp	Solder contact		Crimp contact	
										Contact and Contact	Contact and Shell	Contact and Contact	Contact and Shell
RR	302	02			0.5	5.0	●	●	●	1.00	0.95	1.15	1.20
	303	03			0.5	3.0	●	●	●	0.80	0.95	1.35	1.10
	304	04			0.5	2.0	●	●	●	0.80	0.65	1.05	1.05
	305	05			0.35	1.7	●	-	-	0.70	1.00	-	-
	306	06			0.35	1.5	●	-	-	0.60	0.75	-	-
OR	302	02			0.9	10.0	●	●	●	1.00	1.05	1.45	1.20
	303	03			0.9	8.0	●	●	●	1.20	0.90	1.70	1.60
	304	04			0.7	7.0	●	●	●	0.85	0.70	1.35	1.10
	305	05			0.7	6.5	●	●	●	1.00	0.70	1.25	1.20
	306	06			0.5	2.5	●	●	○	0.85	0.65	1.40	1.20
	307	07			0.5	2.5	●	●	○	0.80	0.70	1.40	1.20
	309	09			0.5	2.0	●	●	○	0.60	0.50	1.00	0.85
	312	12			0.35	1.5	●	-	-	0.80	1.00	-	-

● First Recommendation ○ Special order alternative

■ Metal Material & Plate

PMG · OR · 302 · C L A C 29

Metal material&plate:

Reference	Out shell+collet nut		Latch sleeve+earth crown		Other metallic components		Remarks	Notes
	Material	Surftreatment	Material	Surftreatment	Material	Surftreatment		
C	Brass	Chrome	Brass-bronze	Nickel	Brass	Nickel		●
N	Brass	Nickel	Brass-bronze	Nickel	Brass	Nickel		○
K	Brass	Black Chrome	Brass-bronze	Nickel	Brass	Nickel		●
S	Stainless steel	-	Brass-bronze	Nickel	Brass	Nickel		●
P	PSU	-	Brass-bronze	Nickel	Brass	Nickel	Available for some parts of B series	●
H	PPS/Brass	-/Nickel	Brass-bronze	Nickel	Brass	Nickel	Only for elbow sockets (B series)	●

● First Recommendation ○ Special order alternative

■ Insulator & Contact Type

PMG · OR · 302 · C L A C 29

Insulator & Contact type

	Y	L
Insulator material	PEEK	PEEK
Contact type	Crimp	Solder or print

Contacts reference for plugs free or fixed sockets

Contact type	Reference		Contact (mm)		Conductor Size					
					Solid		Stranded			
	Male	Female	Pin OD	Wire OD	AWG max.	Section max. (mm ²)	AWG		Section (mm ²)	
							min.	max.	min.	max.
Solder	A	L	0.5	0.4	28	0.09		30		0.05
			0.5	0.45	28	0.09		28		0.09
			0.7	0.8	22	0.34		22		0.34
			0.9	0.8	22	0.34		22		0.34
			1.3	1.0	20	0.50		20		0.50
			1.6	1.4	16	1.00		18		1.00
			2.0	1.8	14	1.50		16		1.50
			3.0	2.7	10	4.00		12		4.00

■ Collet Type



PMG · OR · 302 · C L A C 29

Cable OD
Collet Type: C

Series	Reference		Cable OD	
	Type	Code	Max.	Min.
RR	C	27	2.6	2.4
	C	31	3.0	2.7
OR	C	10	1.2	1.0
	C	15	1.5	1.3
	C	20	2.0	1.6
	C	25	2.5	2.1
	C	30	3.0	2.6
	C	35	3.5	3.1
	C	40	4.0	3.6
	C	45	4.5	4.1
	C	50	5.0	4.6

P Series

Key Features:

1P Series allow up to 14 solder contacts. 2P Series, allows up to 32 solder contacts. Top quality lightweight but rugged materials have been chosen to optimize most applications. Polysulfone (PSU), UL certified as autoextinguishable, applicable to medical environment. The contacts are gold-plated over copper and nickel to ensure at least 1000 mating/unmating cycles without significantly affecting the electrical characteristics. Five keys on the plug nose will allow blind mating. Colour coding of the plug and socket flange will give an instant visual indication as to whether connectors are compatible or not. Water resistant to IP64 options are available.



Plastic Series Part Number Definition

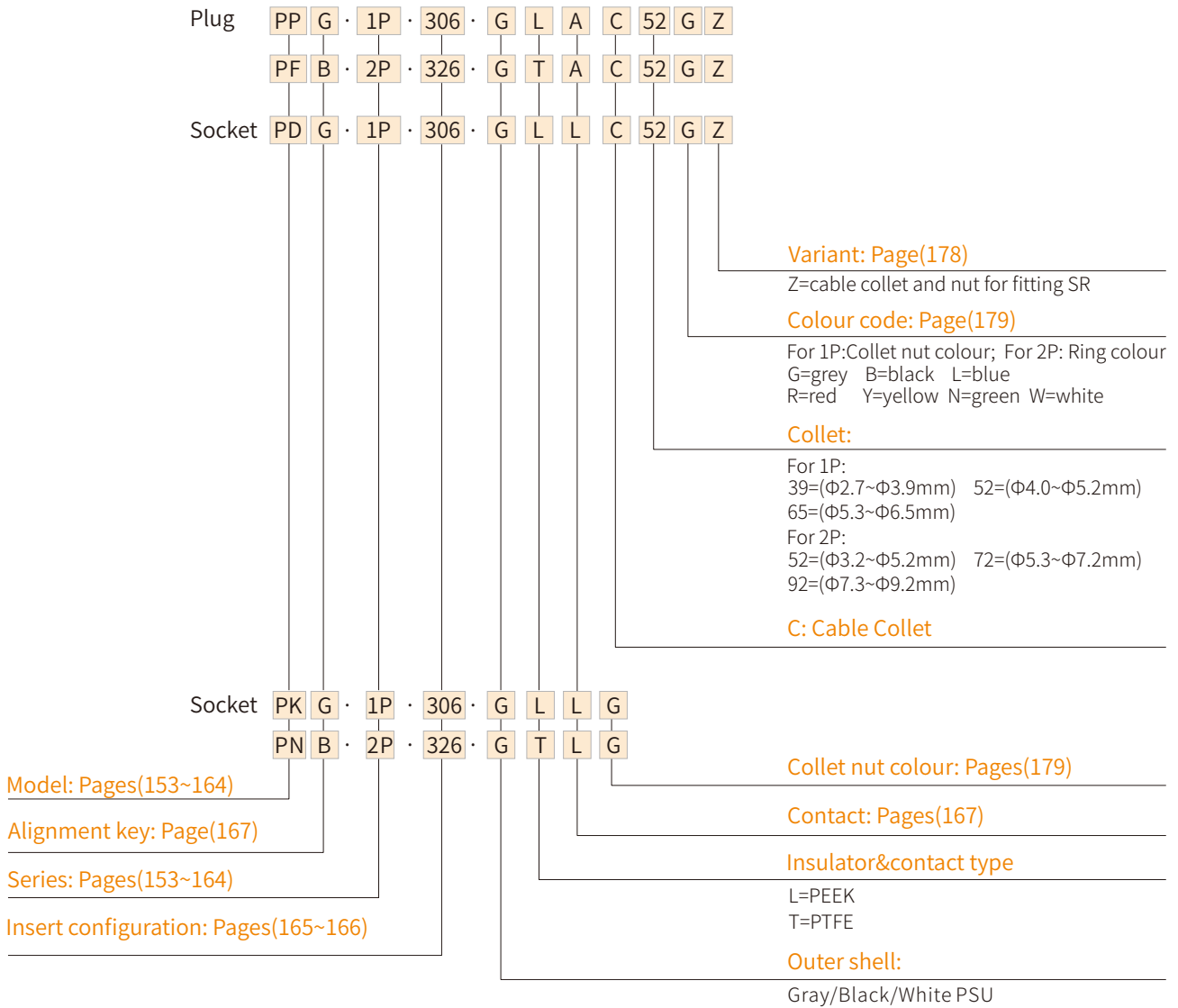

Part Number Example

Straight Plug With Cable Collet:

PPG.1P.306.CLAD52=straight plug with key(G) and cable collet,1P Series, ultipole type with 6 contacts,outershell grey PSU, PEEK insulator male solder contacts, collet for 5.2mm diameter cable.

Fixed Socket:

PKG.1P.306.GLLG=fixed socket, nut fixing, with key(G),1P series, multiple type with 6 contacts, outer shell grey PSU, PEEK extended insulator, female solder contacts, with grey collet nut.

■ 1P Series, PPG Straight Plug, Key(G)

- Connector series: 1P
- Connector gender: Male
- Key: G(More keys, refer to page 167)
- Locking type: Self-locking
- Orientation type: Straight
- Part No.: PPG.1P.3XX.GLACXXG
- Mated with: PKG series

Note: "X" refers to part number definition on page 152

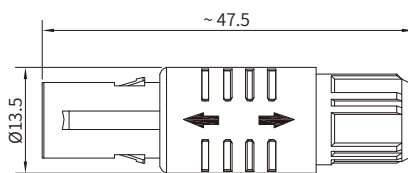

■ General Information

Ambient temperature:	-50 °C ~ + 150 °C
Endurance:	>1000 cycles
Insulator:	PEEK
Backnut:	PSU

Outershell:	PSU
Connector contacts:	Brass with gold plated
Insulator resistance:	≥100MΩ
IP rating:	IP50

■ 1P Series, PPG Straight Plug, Key(G), Backnut For Fitting A Bend Relief

- Connector series: 1P
- Connector gender: Male
- Key: G(More keys, refer to page 167)
- Locking type: Self-locking
- Orientation type: Straight
- Part No.: PPG.1P.3XX.GLACXXZ
- Mated with: PKG series

Note: "X" refers to part number definition on page 152

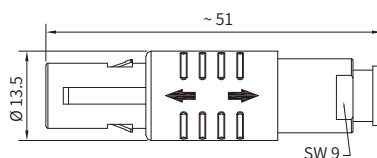

■ General Information

Ambient temperature:	-50 °C ~ + 150 °C
Endurance:	>1000 cycles
Insulator:	PEEK
Backnut:	PSU

Outershell:	PSU
Connector contacts:	Brass with gold plated
Insulator resistance:	≥100MΩ
IP rating:	IP50

■ 1P Series, PKG Fixed Straight Socket, Key(G), With Two Nuts

- Connector series: 1P
- Connector gender: Female
- Key: G(More keys, refer to page 167)
- Locking type: Self-locking
- Orientation type: Straight
- Part No.: PKG.1P.3XX.GLLG
- Mated with: PPG series

Note: "X" refers to part number definition on page 152

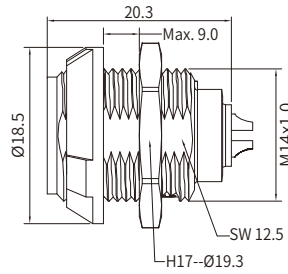

■ General Information

Ambient temperature:	-50 °C ~ + 150 °C
Endurance:	>1000 cycles
Insulator:	PEEK
Fixing nut:	PSU & Brass with nickel plated

Outershell:	PSU
Connector contacts:	Bronze with gold plated
Insulator resistance:	≥100MΩ
IP rating:	IP 50

Note: Panel cut-out (page 180); PCB drilling pattern (page 181)

■ 1P Series, PKG Fixed Straight Socket, Key(G), With Two Nuts, Contact For Printed Circuit

- Connector series: 1P
- Connector gender: Female
- Key: G(More keys, refer to page 167)
- Locking type: Self-locking
- Orientation type: Straight
- Part No.: PKG.1P.3XX.GLNG
- Mated with: PPG series

Note: "X" refers to part number definition on page 152

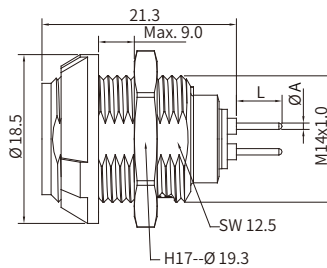

■ General Information

Ambient temperature:	-50 °C ~ + 150 °C
Endurance:	>1000 cycles
Insulator:	PEEK
Fixing nut:	PSU & Brass with nickel plated

Outershell:	PSU
Connector contacts:	Bronze with gold plated
Insulator resistance:	≥100MΩ
IP rating:	IP 50

Pin	Dimensions(mm)	
	ØA	L
302~305	0.7	5.0
306~314	0.5	3.0

Notes: 1.for panel cut-out see page 180; 2.for PCB drilling pattern see page 181

■ 1P Series, PLG Fixed Straight Socket, Key(G), Nut Fixing

- Connector series: 1P
 - Connector gender: Female
 - Key: G(More keys, refer to page 167)
 - Locking type: Self-locking
 - Orientation type: Straight
 - Part No.: PLG.1P.3XX.GLLG
 - Mated with: PPG series
- Note: "X" refers to part number definition on page 152

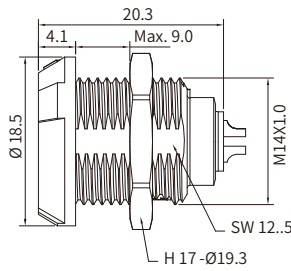

■ General Information

Ambient temperature:	-50 °C ~ + 150 °C
Endurance:	> 1000 cycles
Insulator:	PEEK
Fixing nut:	Brass with nickel plated

Outershell:	PSU
Connector contacts:	Bronze with gold plated
Insulator resistance:	≥ 100MΩ
IP rating:	IP50

Note: Panel cut-out (page 180)

■ 1P Series, PLG Fixed Straight Socket, Key(G), Nut Fixing, Contact For Printed Circuit

- Connector series: 1P
 - Connector gender: Female
 - Key: G(More keys, refer to page 167)
 - Locking type: Self-locking
 - Orientation type: Straight
 - Part No.: PLG.1P.3XX.GLNG
 - Mated with: PPG series
- Note: "X" refers to part number definition on page 152

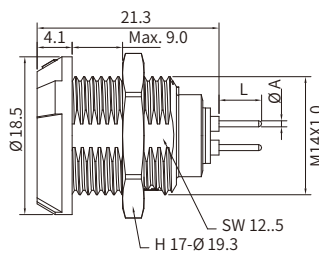

■ General Information

Ambient temperature:	-50 °C ~ + 150 °C
Endurance:	> 1000 cycles
Insulator:	PEEK
Fixing nut:	Brass with nickel plated

Outershell:	PSU
Connector contacts:	Bronze with gold plated
Insulator resistance:	≥ 100MΩ
IP rating:	IP50

Pin	Dimensions(mm)	
	ØA	L
302~305	0.7	5.0
306~314	0.5	3.0

Notes: 1.for panel cut-out see page 180; 2.for PCB drilling pattern see page 181

■ 1P Series, PKG Fixed Socket, Key(G), With Two Nuts, With 90° Elbow Contact For Printed Circuit

- Connector series: 1P
 - Connector gender: Female
 - Key: G(More keys, refer to page 167)
 - Locking type: Self-locking
 - Orientation type: 90° elbow
 - Part No.: PKG.1P.3XX.GLVG
 - Mated with: PPG series
- Note: "X" refers to part number definition on page 152

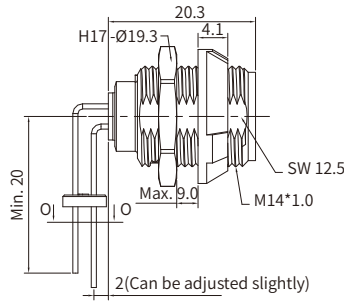

■ General Information

Ambient temperature:	-50 °C ~ + 150 °C
Endurance:	>1000 cycles
Insulator:	PEEK
Fixing nut:	PSU & Brass with nickel plated

Outershell:	PSU
Connector contacts:	Bronze with gold plated
Insulator resistance:	≥100MΩ
IP rating:	IP50

Notes: 1.for panel cut-out see page 180; 2.for PCB drilling pattern see page 183

■ 1P Series, PDG Free Socket, Key(G)

- Connector series: 1P
 - Connector gender: Female
 - Key: G(More keys, refer to page 167)
 - Locking type: Self-locking
 - Orientation type: Straight
 - Part No.: PDG.1P.3XX.GLLCXXG
 - Mated with: PPG series
- Note: "X" refers to part number definition on page 152

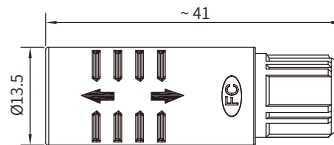

■ General Information

Ambient temperature:	-50 °C ~ + 150 °C
Endurance:	>1000 cycles
Insulator:	PEEK
Backnut:	PSU

Outershell:	PSU
Connector contacts:	Bronze with gold plated
Insulator resistance:	≥100MΩ
IP rating:	IP 50

■ 1P Series, PDG Free Socket, Key(G), Backnut For Fitting A Bend Relief

- Connector series: 1P
 - Connector gender: Female
 - Key: G(More keys, refer to page 167)
 - Locking type: Self-locking
 - Orientation type: Straight
 - Part No.: PDG.1P.3XX.GLLCXXGZ
 - Mated with: PPG series
- Note: "X" refers to part number definition on page 152

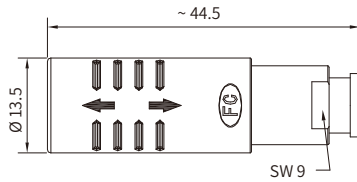

■ General Information

Ambient temperature:	-50 °C ~ + 150 °C
Endurance:	>1000 cycles
Insulator:	PEEK
Backnut:	PSU

Outershell:	PSU
Connector contacts:	Bronze with gold plated
Insulator resistance:	≥100MΩ
IP rating:	IP50

■ 1P Series, PFG Straight Plug, Waterproof, Key(G), Backnut For Fitting A Bend Relief

- Connector series: 1P
 - Contact: Male
 - Key: A/B/C/G (More keys, refer to page 167)
 - Locking type: Self-locking
 - Orientation type: Straight
 - Part No.: PFG.1P.XXX.GLACXXGZ
 - Mated with: PNG series
- Note: "X" refers to part number definition on page 152

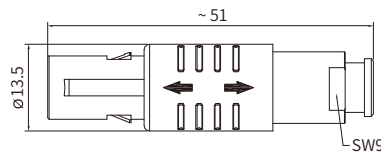

■ General Information

Ambient temperature:	-50 °C ~ + 90 °C
Endurance:	>1000 cycles
Insulator:	PEEK
Backnut:	PSU
Outershell:	PSU

Seal:	Silicone
Connector contacts:	Brass with gold plated
Insulator resistance:	≥100MΩ
IP rating:	IP 64 (with bend relief)

■ 1P Series, PNG Fixed Straight Socket, Waterproof, Key(G), Nut Fixing

- Connector series: 1P
- Connector gender: Female
- Key: G(More keys, refer to page 167)
- Locking type: Self-locking
- Orientation type: Straight
- Part No.: PNG.1P.3XX.GLLG
- Mated with: PFG series

Note: "X" refers to part number definition on page 152

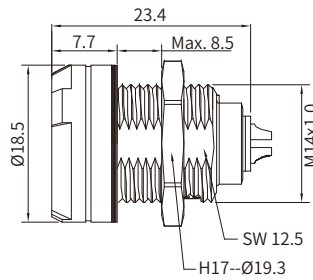

■ General Information

Ambient temperature:	-50 °C ~ + 90 °C
Endurance:	>1000 cycles
Insulator:	PEEK
Fixing nut:	Brass with nickel plated
Outershell:	PSU

Seal:	Silicone
Connector contacts:	Bronze with gold plated
Insulator resistance:	≥100MΩ
IP rating:	IP 64

■ 1P Series, PNG Fixed Straight Socket, Waterproof, Key(G), Nut Fixing, Contact For Printed Circuit

- Connector series: 1P
- Connector gender: Female
- Key: G(More keys, refer to page 167)
- Locking type: Self-locking
- Orientation type: Straight
- Part No.: PNG.1P.3XX.GLNG
- Mated with: PFG series

Note: "X" refers to part number definition on page 152

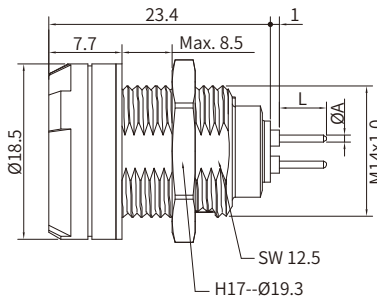

■ General Information

Ambient temperature:	-50 °C ~ + 90 °C
Endurance:	>1000 cycles
Insulator:	PEEK
Fixing nut:	Brass with nickel plated
Outershell:	PSU

Seal:	Silicone
Connector contacts:	Bronze with gold plated
Insulator resistance:	≥100MΩ
IP rating:	IP 64

Pin	Dimensions(mm)	
	ØA	L
302~305	0.7	5.0
306~314	0.5	3.0

Notes: 1. for panel cut-out see page 180; 2. for PCB drilling pattern see page 181

■ 2P Series, PPB Straight Plug, Key(B)

- Connector series: 2P
- Connector gender: Male
- Key: B
- Locking type: Self-locking
- Orientation type: Straight
- Part No.: PPB.2P.3XX.GLACXXG
- Mated with: PLB series

Note: "X" refers to part number definition on page 152

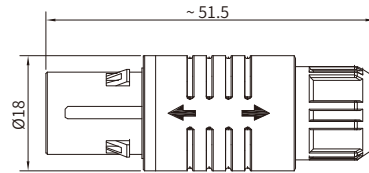

■ General Information

Ambient temperature:	-50 °C ~ + 150 °C
Endurance:	>1000 cycles
Insulator:	PEEK
Backnut:	PSU

Outershell:	PSU
Connector contacts:	Brass with gold plated
Insulator resistance:	≥100MΩ
IP rating:	IP 50

■ 2P Series, PPB Straight Plug, Key(B), Backnut For Fitting A Bend Relief

- Connector series: 2P
- Connector gender: Male
- Key: B
- Locking type: Self-locking
- Orientation type: Straight
- Part No.: PPB.2P.3XX.GLACXXGZ
- Mated with: PLB series

Note: "X" refers to part number definition on page 152

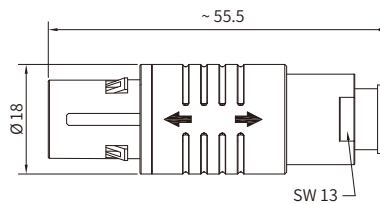

■ General Information

Ambient temperature:	-50 °C ~ + 150 °C
Endurance:	>1000 cycles
Insulator:	PEEK
Backnut:	PSU

Outershell:	PSU
Connector contacts:	Brass with gold plated
Insulator resistance:	≥100MΩ
IP rating:	IP50

■ 2P Series, PLB Fixed Straight Socket, Key(B)

- Connector series: 2P
- Connector gender: Female
- Key: B
- Locking type: Self-locking
- Orientation type: Straight
- Part No.: PLB.2P.3XX.GLLG
- Mated with: PPB series

Note: "X" refers to part number definition on page 152

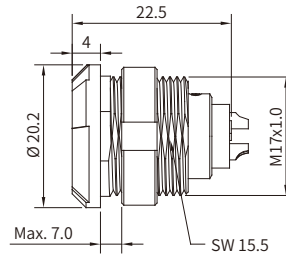

■ General Information

Ambient temperature:	-50 °C ~ + 150 °C
Endurance:	>1000 cycles
Insulator:	PEEK
Fixing nut:	PSU

Outershell:	PSU
Connector contacts:	Bronze with gold plated
Insulator resistance:	≥100MΩ
IP rating:	IP 50

■ 2P Series, PLB Fixed Straight Socket, Key(B), Contact For Printed Circuit

- Connector series: 2P
- Connector gender: Female
- Key: B
- Locking type: Self-locking
- Orientation type: Straight
- Part No.: PLB.2P.3XX.GLNG
- Mated with: PPB series

Note: "X" refers to part number definition on page 152

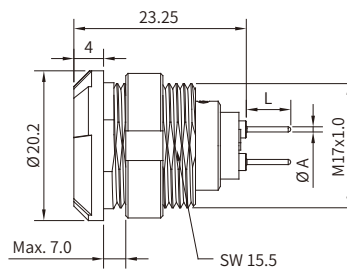

■ General Information

Ambient temperature:	-50 °C ~ + 150 °C
Endurance:	>1000 cycles
Insulator:	PEEK
Fixing nut:	PSU

Outershell:	PSU
Connector contacts:	Bronze with gold plated
Insulator resistance:	≥100MΩ
IP rating:	IP 50

Pin	Dimensions(mm)	
	ØA	L
302~319	0.7	5.6
326~332	0.5	3.4

Note: Panel cut-out (P 180); PCB drilling pattern (P 182)

■ 2P Series, PKB Fixed Straight Socket , Key(B)

- Connector series: PKB
- Contact: Female
- Coding: B(More coding, refer to PXX)
- Locking type: Self-locking
- Orientation type: Straight
- Part No.: PKB.2P.3XX.GLLG
- Mated with: PPB

Note: "X" refers to part number definition on page 152

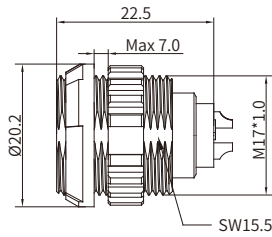

■ General Information

Ambient temperature:	-55 °C ~ + 250 °C	Coupling nut:	PSU
Endurance:	> 1000 cycles	Housing:	PSU
Insulator:	PEEK	Insulator resistance:	≥ 100MΩ
Connector contacts:	Brass with gold plated	IP rating:	IP 50

■ 2P Series, PFB Straight Plug, Waterproof, Key(B), Backnut For Bend Relief

- Connector series: 2P
- Connector gender: Male
- Key: B
- Locking type: Self-locking
- Orientation type: Straight
- Part No.: PFB.2P.3XX.GLACXXGZ
- Mated with: PNB series

Note: "X" refers to part number definition on page 152

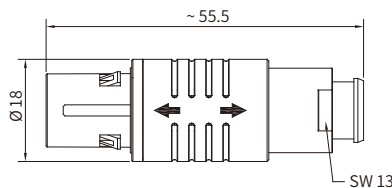

■ General Information

Ambient temperature:	-50 °C ~ + 150 °C	Outershell:	PSU
Endurance:	> 1000 cycles	Connector contacts:	Brass with gold plated
Insulator:	PEEK	Insulator resistance:	≥ 100MΩ
Backnut:	PSU	IP rating:	IP 66 (with bend relief)
Seal:	Silicone		

■ 2P Series, PNB Fixed Straight Socket, Waterproof, Key(B)

- Connector series: 2P
- Connector gender: Female
- Key: B
- Locking type: Self-locking
- Orientation type: Straight
- Part No.: PNB.2P.3XX.GLLG
- Mated with: PFB series

Note: "X" refers to part number definition on page 152

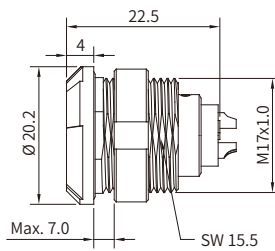

■ General Information

Ambient temperature:	-50 °C ~ + 150 °C
Endurance:	>1000 cycles
Insulator:	PEEK
Fixing nut:	PSU
Seal:	Silicone

Outershell:	PSU
Connector contacts:	Bronze with gold plated
Insulator resistance:	≥100MΩ
IP rating:	IP 66

■ 2P Series, PNB Fixed Straight Socket, Waterproof, Key(B), Contact For Printed Circuit

- Connector series: 2P
- Connector gender: Female
- Key: B
- Locking type: Self-locking
- Orientation type: Straight
- Part No.: PNB.2P.3XX.GLNG
- Mated with: PFB series

Note: "X" refers to part number definition on page 152

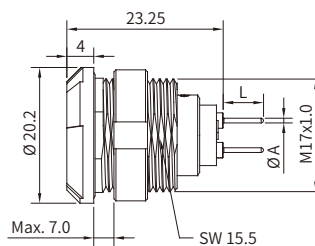

■ General Information

Ambient temperature:	-50 °C ~ + 150 °C
Endurance:	>1000 cycles
Insulator:	PEEK
Fixing nut:	PSU
Seal:	Silicone

Outershell:	PSU
Connector contacts:	Bronze with gold plated
Insulator resistance:	≥100MΩ
IP rating:	IP 66

Pin	Dimensions(mm)	
	A	L
302~319	0.7	5.6
326/332	0.5	3.4

Note: Panel cut-out (P 180); PCB drilling pattern (P 182)

■ 2P Series, PFB Straight Plug, key (B), Backnut For Fitting A Bend Relief, High Voltage

- Connector series: PFB
- Contact: Male
- Locking type: Self-locking
- Mounting type: Straight
- Part No.: PFB.2P.326.GTACXXGZ
- Mated with: PNB series

Note: "X" refers to part number definition on page 152

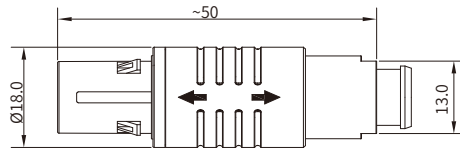

■ General Information

Ambient temperature:	-50 °C ~ + 150 °C	Outershell:	PSU
Endurance:	> 1000 cycles	IP rating:	IP50
Insulator:	PTFE	Insulator resistance:	≥100MΩ
Connector contacts:	Brass with gold plated	Backnut:	PSU

	Contact parameter			
	Rated current	Test voltage	ØA (mm)	Adapter wire diameter
	2.5A	4000V	0.5	30AWG

■ 2P Series, PNB Fixed Socket, Key(B), High Voltage

- Connector series: PNB
- Contact: Female
- Locking type: Self-locking
- Mounting type: Straight
- Part No.: PNB.2P.326.GTLG
- Mated with: PFB series

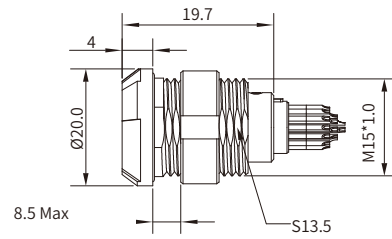

■ General Information

Ambient temperature:	-50 °C ~ + 150 °C	Outershell:	PSU
Endurance:	> 1000 cycles	IP rating:	IP50
Insulator:	PTFE	Insulator resistance:	≥100MΩ
Connector contacts:	Brass with gold plated	Backnut:	PSU

	Contact parameter			
	Rated current	Test voltage	ØA (mm)	Adapter wire diameter
	2.5A	4000V	0.5	30AWG

■ 2P Series, PSB Free Straight Socket, Key(B)

- Connector series: 2P
- Contact: Female
- Coding: B
- Locking type: Self-locking
- Orientation type: Straight
- Part No.: PSB.2P.3XX.GLLCXXGZ
- Mated with: PPB

Note: "X" refers to part number definition on page 152

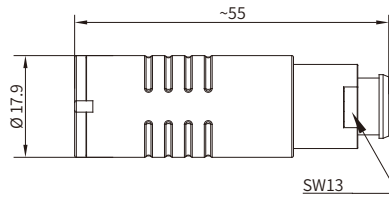

■ General Information

Ambient temperature:	-55 °C ~ + 150 °C
Endurance:	>1000 cycles
Insulator:	PEEK
Connector contacts:	Brass with gold plated

Housing:	PSU
Insulator resistance:	≥100MΩ
IP rating:	IP 50

■ Electrical & Mechanical Data

PP G · 1P · 306 · G L A C 52 G

Insert configuration

Size	Part.No	Pin Count	Pin layout From the direction of solder		Contact Dim (mm)	Rated current (A)	Contact type			Test voltage (KV rms)
			Male	Female			Solder	Print	Crimp	
1P	302	02			1.3	10.0	●	●	●	1.20
	304	04			0.9	8.0	●	●	●	1.20
	305	05			0.9	7.0	●	●	●	1.05
	306	06			0.7	6.0	●	●	●	1.05
	307	07			0.7	5.0	●	●	●	1.05
	308	08			0.7	5.0	●	●	●	1.05
	309	09			0.5	3.0	●	●		0.85
	310	10			0.5	3.0	●	●		0.85
	314	14			0.5	2.0	●	●		0.60

It is proposed according to the following ratio : Operating Voltage (Us) = Test voltage(Ue) / 3

● First Recommendation

Caution:

For a number of applications, safety requirements for electrical appliances are more severe with regard to operating voltage.

In such cases operating voltage is defined according to creepage distance and air clearance) between live parts.

■ Electrical & Mechanical Data

Size	Part.No	Pin Count	Pin layout From the direction of solder		Contact Dim (mm)	Rated current (A)	Contact type			Test voltage (KV rms)
			Male	Female			Solder	Print	Crimp	
2P	302	02			2.0	30.0	●	●	●	2.10
	303	03			1.6	17.0	●	●	●	2.40
	304	04			1.3	15.0	●	●	●	1.85
	305	05			1.3	14.0	●	●	●	1.75
	306	06			1.3	12.0	●	●	●	1.35
	307	07			1.3	11.0	●	●	●	1.75
	308	08			0.9	10.0	●	●	●	1.50
	310	10			0.9	8.0	●	●	●	1.45
	312	12			0.7	7.0	●	●	●	1.25
	316	16			0.7	6.0	●	●	●	1.50
	319	19			0.7	5.0	●	●	●	1.40
	326	26			0.5	2.0	●	●		1.00
	332	32			0.5	1.5	●	●		0.7

It is proposed according to the following ratio : Operating Voltage (Us) = Test voltage(Ue) / 3

● First Recommendation

Caution:

For a number of applications, safety requirements for electrical appliances are more severe with regard to operating voltage.

In such cases operating voltage is defined according to creepage distance and air clearance) between live parts.

■ Alignment Key, Contact type

PP G · 1P · 306 · G L A C 52 G

Alignment key:
1P series

CODING	Key Count	Graphical
G	1 Key	
A	2 Keys	
B	2 Keys	
C	2 Keys	

2P series

CODING	Key Count	Graphical
B	3 Key	

PK G · 1P · 306 · G L L G

Contact type:

Type	Contact Type	
	Male	Female
solder	A	L
crimp	C	M
print	D	N
Angled print	--	V

○ Cable Assembly

Finecables provides cables and assembly to customize your connectivity solutions

Finecables plants stock a wide range of standard cables and have the ability to customize cables to provide customers with better service and to optimize the delivery time of cable assembly.

Among them, standard cables include power and signal data transmission, coaxial RF, optical fiber, hybrid installation, etc., without MOQ, to meet the customer's requirements for various cable assembly.

And we also have a professional cable R&D team to design customized cables for customers to meet high and low temperature, deep water, acid and alkali, heavy load, tow chain and other harsh environments and special requirements.

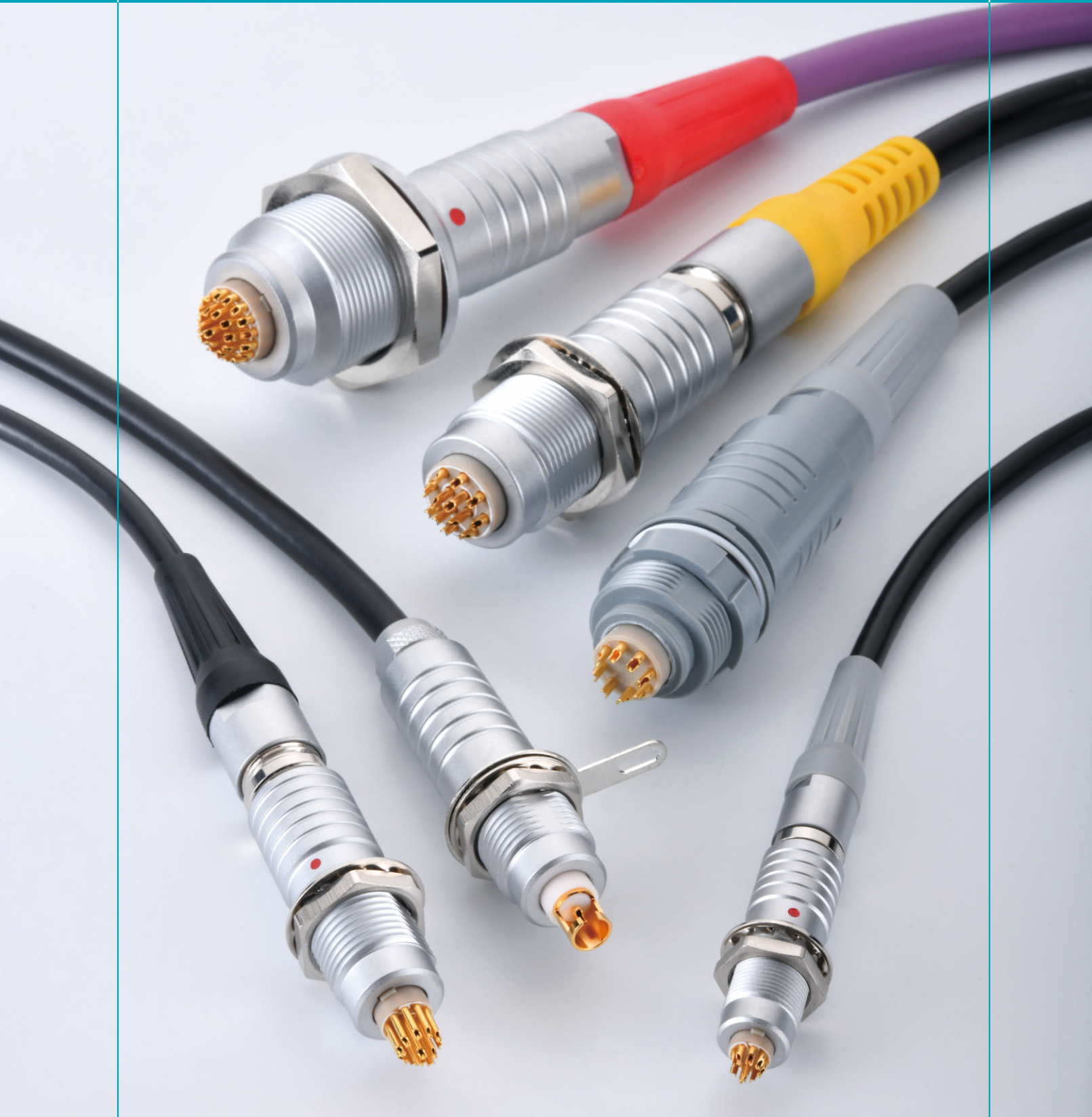

■ Wire

■ FEP Wire

Wire Type	Conductor			Insulation		Ambient temperature		Rated voltage (V)	Weight (KG/KM)
	Material	Parameters	Gauge AWG	Material	Dia.	Min	Max		
FC.FP*01.2001	Tinned copper wire	42/0.127	AWG20	FEP	1.4	-60	200	300	7.3
FC.FP*01.2201	Tinned copper wire	19/0.15	AWG22	FEP	1.15	-60	200	300	6
FC.FP*01.2401	Tinned copper wire	19/0.12	AWG24	FEP	1	-60	200	300	4.2
FC.FP*01.2601	Tinned copper wire	19/0.10	AWG26	FEP	0.9	-60	200	300	2.8
FC.FP*01.2801	Tinned copper wire	19/0.08	AWG28	FEP	0.7	-60	200	300	1.7

■ UL1007 Wire

Wire Type	Conductor			Insulation		Ambient temperature		Rated voltage (V)	Weight (KG/KM)
	Material	Parameters	Gauge AWG	Material	Dia.	Min	Max		
FC.PV*01.1801	Tinned copper wire	34/0.18	AWG18	PVC	2	-20	80	300	6
FC.PVJV1.2201	Tinned copper wire	17/0.16	AWG22	PVC	1.6	-20	80	300	5.6
FC.PV*01.2201	Tinned copper wire	17/0.16	AWG22	PVC	1.6	-20	80	300	5.6
FC.PV*01.2401	Tinned copper wire	11/0.16	AWG24	PVC	1.4	-20	80	300	3.9

Note: The "*" in the model indicates the color of the jacket. Please refer to the table below for details, and use the color letter instead of "*".

Reference	L	W	G	T	Y	M	B	P	R	S	N
Color	Blue	White	Grey	Transparent	Yellow	Brown	Black	Purple	Red	Orange	Green

■ Industrial Control Cable

■ Wear- Resistant PUR Jacket Cable

Cable Type	Conductor				Insulation		Shielded			Jacket			Rated voltage	Ambient temperature
	Parameters	Gauge AWG	Contact	Material	Material	Dia.	Structure	Material	Coverage	Material	Dia.	Color		
FC.PRN02.2201	19/0.16	AWG22	2C	Tinned copper wire	PP	1.3	Braids+Aluminum mylar	Tinned copper wire	85%	PU	4.8	Black	60V	-40°C~+80°C
FC.PRN02.2601	7/0.16	AWG26	2C	Tinned copper wire	PE	0.8	Spiral+Aluminum mylar	Tinned copper wire	95%	PU	3.2	Black	60V	-40°C~+80°C
FC.PRN02.2201	19/0.16	AWG22	3C	Tinned copper wire	HDPE	1.3	Braids+Aluminum mylar	Tinned copper wire	85%	PU	4.8	Black	300V	-40°C~+80°C
FC.PRN02.1602	65/0.16	AWG16	4C	Tinned copper wire	HDPE	2	/	/	/	PU	6.4	Black	300V	-40°C~+80°C
FC.PRN02.2801	7/0.127	AWG28	4C	Tinned copper wire	PP	0.75	Braids	Tinned copper wire	85%	PU	3.5	Black	60V	-40°C~+80°C
FC.PRN02.2001	26/0.16	AWG20	4C	Tinned copper wire	PP	1.6	Braids+Aluminum mylar	Tinned copper wire	85%	PU	6	Black	300V	-40°C~+80°C
FC.PRN02.2401	19/0.12	AWG24	5C	Tinned copper wire	HDPE	0.95	Braids+Aluminum mylar	Tinned copper wire	85%	PU	4.8	Black	300V	-40°C~+80°C
FC.PRN02.2601	7/0.16	AWG26	6C	Tinned copper wire	PP	0.9	Braids+Aluminum mylar	Tinned copper wire	85%	PU	5.3	Black	300V	-40°C~+80°C
FC.PRN02.2801	19/0.08	AWG28	2P+2C	Tinned copper wire	PP	0.65	Aluminum mylar+Spiral	Tinned copper wire	95%	PU	4.2	Black	60V	-40°C~+80°C
FC.PRN02.2803	7/0.127	AWG28	3P+1C	Tinned copper wire	PP	0.7	Braids+Aluminum mylar	Tinned copper wire	90%	PU	5	Black	60V	-40°C~+80°C
FC.PRN02.3001	7/0.10	AWG30	7C	Tinned copper wire	PP	0.55	Braids+Aluminum mylar	Tinned copper wire	85%	PU	3.2	Black	60V	-40°C~+80°C
FC.PRN25.2428	19/0.12	AWG24	2C	Tinned copper wire	HDPE	1	Acclivitous cover+Aluminum mylar	Tinned copper wire	90%	PU	5	Black	60V	-40°C~+80°C
	7/0.127	AWG28	1P+3C	Tinned copper wire	HDPE	0.8				PU				
FC.PRN02.2803	19/0.08	AWG28	1P+7C	Tinned copper wire	FEP	0.75	Braids+Aluminum mylar	Tinned copper wire	90%	PU	5	Black	300V	-40°C~+80°C
FC.PRN02.2201	30/0.12	AWG22	10C	Tinned copper wire	PP	1.1	Acclivitous cover	Tinned copper wire	90%	PU	6.8	Black	300V	-40°C~+80°C
FC.PRN02.2601	19/0.10	AWG26	10C	Tinned copper wire	PP	0.85	Acclivitous cover	Tinned copper wire	95%	PU	5.5	Black	60V	-40°C~+80°C
FC.PRN02.2801	7/0.127	AWG28	10C	Tinned copper wire	PE	0.7	Braids+Aluminum mylar	Tinned copper wire	85%	PU	5.3	Black	60V	-40°C~+80°C
FC.PRN02.3001	7/0.10	AWG30	1P+10C	Tinned copper wire	PP	0.6	Braids+Aluminum mylar	Tinned copper wire	85%	PU	4.8	Black	60V	-40°C~+80°C
FC.PRN02.2601	19/0.1	AWG26	16C	Tinned copper wire	HDPE	0.85	Spiral+Aluminum mylar	Tinned copper wire	90%	PU	6.5	Black	60V	-40°C~+80°C
FC.PRN02.2802	7/0.127	AWG28	16C	Tinned copper wire	PP	0.7	Braids+Aluminum mylar	Tinned copper wire	85%	PU	5.8	Black	60V	-40°C~+80°C
FC.PRN02.2201	30/0.12	AWG22	19C	Tinned copper wire	PP	1.1	Braids+Aluminum mylar	Tinned copper wire	90%	PU	8.2	Black	300V	-40°C~+80°C

■ Data+Coaxial Cable

■ Twisted Pair Data Cable

Cable Type	Conductor				Insulation		Shielded			Jacket			Rated voltage	Ambient temperature
	Parameters	Gauge AWG	Contact	Material	Material	Dia.	Structure	Material	Coverage	Material	Dia.	Color		
FC.PRN08.2401	7/0.2	AWG24	4P	Bare copper wire	HDPE	1	Tinned copper wire	Tinned copper wire	60%	PU	5.7	Black	60V	-40°C~+80°C
FC.PRN16.2603	19/0.10	AWG26	8P	Tinned copper wire	PP	0.9	Tinned copper wire	Tinned copper wire	80%	PU	7	Black	30V	-40°C~+80°C
FC.PRN26.2801	7/0.127	AWG28	13P	Tinned copper wire	PP	0.62	Tinned copper wire	Tinned copper wire	65%	PVC	6.3	Black	30V	-40°C~+82°C
FC.PRN32.2601	7/0.16	AWG26	16P	Tinned copper wire	HDPE	0.8	Tinned copper wire	Tinned copper wire	85%	PU	8.3	Black	60V	-40°C~+80°C
FC.PRN48.2601	7/0.16	AWG26	24P	Tinned copper wire	PP	0.8	Tinned copper wire	Tinned copper wire	85%	PU	9.9	Black	60V	-40°C~+80°C

■ High Temperature Resistant Data Cable

Cable Type	Conductor				Insulation		Shielded			Jacket			Rated voltage	Ambient temperature
	Parameters	Gauge AWG	Contact	Material	Material	Dia.	Structure	Material	Coverage	Material	Dia.	Color		
FC.SRN04.2601	39/0.07	AWG26	4C	Tinned copper wire	FEP	0.85	Braids	Tinned copper wire	80%	Silicone	4.7	Black	300V	-60°C~+200°C
FC.SRN06.2401	7/0.22	AWG24	3P	Tinned copper wire	FEP	1.1	Braids	Tinned copper wire	85%	Silicone	6.5	Black	600V	-60°C~+200°C
FC.SGG08.2801	7/0.12	AWG28	8C	Tinned copper wire	FEP	0.68	Braids	Tinned copper wire	85%	Silicone	5.5	Gray	300V	-60°C~+200°C

■ Single Core Coaxial Cable

Cable Type	Conductor		Insulation		Shielded		Jacket			Characteristic Resistance (Ohm)	Test voltage (DC/1min)	Ambient temperature
	Parameters	Material	Material	Dia.	Material	Coverage	Material	Dia.	Color			
FC.FPG01.5001	7/0.08	Silver plated copper wire	PFA	0.68	Silver plated copper wire	95%	PFA	1.13	Gray	50	0.5KV	-55°C~+180°C
FC.RG178.0001	7/0.1	Silver plated copper wire	PTFE	0.86	Silver plated copper wire	90%	FEP	1.8	Light brown	50	3KV	-40°C~+200°C
FC.RG316.5001	7/0.18	Silver plated copper wire	PTFE	1.5	Silver plated copper wire	90%	FEP	2.54	Light brown	50	3.6KV	-40°C~+200°C
FC.017420	7/0.16	Bare copper	PE	1.5	Tinned copper wire	85%	PVC	2.8	Black	50	3KV	-20°C~+80°C
FC.PRN01.2601	7/0.16	Tinned copper wire	PE	1.5	Tinned copper wire	95%	TPU	2.8	Black	50	2KV	-40°C~+80°C
FC.RG58N.5001	19/0.18	Tinned copper wire	PE	2.95	Tinned copper wire	90%	PVC	5	Black	50	5KV	-20°C~+80°C
FC.RG179.0001	7/0.1	Tinned copper wire	PTFE	1.6	Silver plated copper wire	95%	FEP	2.54	Light brown	75	3.6KV	-40°C~+200°C
FC.PVN01.7501	1/0.25	Bare copper	PE	1.5	Bare copper	96%	PVC	2.8	Black	75	2	-20°C~+80°C
FC.PRN01.7501	7/0.16	Tinned copper wire	PE	2.9	Tinned copper wire	85%	TPU	5	Black	75	2KV	-40°C~+80°C
FC.RG59N.0001	1/0.584	Bare copper clad steel	PE	3.7	Bare copper	95%	PV	6	Black	75	1.7KV	-40°C~+80°C

■ Coaxial Triaxial Cable

Cable Type	Conductor		Insulation		Inner Shield			Inner Jacket		
	Parameters	Material	Material	Dia.	Structure	Material	Coverage	Material	Dia.	Color
FC.SFF50.0201	7/0.18	Silver plated copper wire	PTFE	1.5	Braids	Tinned copper wire	95%	FEP	2.4	Light brown
FC.SFF75.021	7/0.10	Silver plated copper wire	PTFE	1.6	Braids	Tinned copper wire	95%	FEP	2.54	Light brown
FC.TRN75.0001	7/0.16	Bare copper	FM-PE	2.2	Braids	Tinned copper wire	90%	TPE	3.2	Black

Cable Type	External Shield			Jacket			Characteristic Resistance (Ohm)	Test voltage (DC/1min)	Ambient temperature
	Structure	Material	Coverage	Material	Dia.	Color			
FC.SFF50.0201	Braids	Silver plated copper wire	95%	FEP	3.4	Light brown	50	1.5KV	-60°C~+200°C
FC.SFF75.021	Braids	Silver plated copper wire	95%	FEP	3.6	Light brown	75	1.5	-60°C~+200°C
FC.TRN75.0001	Braids	Tinned copper wire	90%	TEP	5	Black	75	2KV	-40°C~+80°C

■ USB2.0

Cable Type	Conductor				Insulation		Shielded			Jacket			Rated voltage	Ambient temperature
	Parameters	Gauge AWG	Contact	Material	Material	Dia.	Structure	Material	Coverage	Material	Dia.	Color		
FC.PRN04.2601	7/0.16	AWG26	2C+1P	Tinned copper wire	PP	1	Braids+Aluminum mylar	Tinned copper wire	80%	PU	4.8	Black	60V	-40°C~+80°C
FC.PRN04.2805	7/0.127	AWG28	2C+1P	Tinned copper wire	PP	0.7	Braids+Aluminum mylar	Tinned copper wire	85%	PU	3.4	Black	30V	-40°C~+80°C

■ USB3.0

Cable Type	Conductor				Insulation		Shielded			Jacket			Rated voltage	Ambient temperature
	Parameters	Gauge AWG	Contact	Material	Material	Dia.	Structure	Material	Coverage	Material	Dia.	Color		
FC.PRN26.2428	7/0.127	AWG28	2P		FM-PE	0.9	Braids+Aluminum mylar	Tinned copper wire	85%	PU	5.7	Black	30V	-40°C~+80°C
	7/0.127	AWG28	1P	Tinned copper wire	HDPE	0.7								
	7/0.2	AWG24	2C+1P		SR-PVC	1.1								

■ Industrial+High Voltage Cable

■ Industrial Network Cable

Cable Type	Conductor					Insulation		Shielded			Jacket			Rated voltage	Ambient temperature
	Parameters	Gauge AWG	Contact	Material	Type	Material	Dia.	Structure	Material	Coverage	Material	Dia.	Color		
FC.PRN04.2605E	7/0.16	AWG26	2P	Bare copper wire	CAT5E	HDPE	0.95	Braids+Aluminum mylar	Tinned copper wire	85%	PU	5	Black	300V	-40°C~+80°C
FC.SGA04.2401	7/0.2	AWG24	2P	Silver plated copper wire	CAT5E	FEP	0.6	Braids+Aluminum mylar	Tinned copper wire	85%	Silicone	6	Blue	300V	-60°C~+80°C
FC.CAT5E.2601	7/0.16	AWG26	4P	Bare copper wire	CAT5E	HDPE	0.9	Braids+Aluminum mylar	Tinned copper wire	65%	LSZH	5.5	Grey	300V	-20°C~+80°C
FC.CAT5E.2602	7/0.16	AWG26	4P	Bare copper wire	CAT5E	HDPE	0.95	Braids+Aluminum mylar	Tinned copper wire	65%	LSZH	5.5	Black	300V	-20°C~+80°C
FC.PRN08.2602	7/0.16	AWG26	4P	Bare copper wire	CAT5E	HDPE	0.9	Braids+Aluminum mylar	Tinned copper wire	65%	PU	5.8	Black	300V	-40°C~+80°C
FC.CAT6A.0002	7/0.16	AWG26	4P	Bare copper wire	CAT6A	FM-PE	0.99	Braids+Aluminum mylar	Tinned copper wire	85%	PU	6.8	Black	300V	-40°C~+80°C

■ Single Core High Voltage Cable

Cable Type	Conductor			Insulation		Shielded			Jacket			Rated voltage	Test voltage (DC/1min)	Ambient temperature
	Parameters	Gauge AWG	Material	Material	Dia.	Structure	Material	Coverage	Material	Dia.	Color			
FC.150470	7/0.25	AWG22	Bare copper wire	LDPE	2.05	Braids	Bare copper wire	85%	PVC	4	Red	3KV	6KV	-20°C~+80°C
FC.106330	14/0.15	AWG24	Tinned copper wire	LDPE	2.8	Braids	Tinned copper wire	85%	PVC	4.6	Red	9KV	18KV	-20°C~+80°C
FC.130660	7/0.25	AWG22	Bare copper wire	SpecialPE	3.9	Braids	Bare copper wire	85%	PVC	5.5	Red	30KV	60KV	-20°C~+105°C

■ Hybrid Cable

■ Coaxial + Low Voltage Hybrid Cable

Cable Type	Coaxial*1C											
	Conductor			Insulation		Shielded			Jacket			
Characteristic Resistance (Ohm)	Parameters (mm)	Material	Material	Dia. (mm)	Structure	Material	Coverage	Material	Dia. (mm)	Color		
50	1/0.3	Tinned copper wire	LDPE	0.9	Braids	Tinned copper wire	85%	PVC	1.9	Black		
Low Voltage*10C												
Conductor				Insulation		Rated voltage (V)						
Gauge AWG	Parameters (mm)	Material	Contact	Material	Dia. (mm)	Rated voltage (V)						
AWG26	19/0.1	Tinned copper wire	10C	HDPE	0.8	30V						
Shielded			Jacket			Ambient temperature						
Structure	Material	Coverage	Material	Dia. (mm)	Color							
Braids	Tinned copper wire	85%	PU	5.5	Black	-40°C~+80°C						

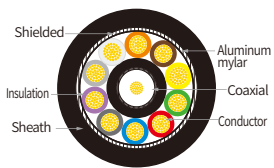

■ Ethernet + Low Voltage Hybrid

Cable Type	Conductor					Insulation		Shielded			Jacket			Rated voltage (V)	Ambient temperature
	Parameters	Gauge AWG	Material	Contact	Type	Material	Dia.	Structure	Material	Coverage	Material	Dia.	Color		
FC.PRN20.2226	7/0.16	AWG26	Bare copper wire	4P	CAT6	PE	1	Braids	Tinned copper wire	80%	PU	9.1	Black	30V	-40°C ~ +75°C
	19/0.15	AWG22	Tinned copper wire	5P	CAT7	PE	1.08								

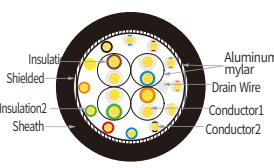

Hybrid Cable

Standard Hybrid Optical Fiber Cable

	Cable Type	Optical Fiber * 2C									
		Optical Fiber				Buffer layer		Jacket			Attenuation (dB/km@1310m)
		Optical Fiber (μm)	Single coating (μm)	Contact	Fiber Reinforcement	Material	Dia. (mm)	Material	Dia. (mm)	Color	
		9/125	330±15	2C	Aramid Fiber	Nylon	0.9	PVC	2	Blue/Yellow	≤0.5
FC.449N1.92SMC	Low Voltage*AWG20*4C+AWG24*2C										
	Conductor				Insulation			Rated voltage (V)			
	Gauge AWG	Parameters	Material	Contact	Material	Dia. (mm)					
	AWG20	19/0.2	Tinned copper wire	4C	HDPE	1.6	600V				
	AWG24	7/0.2	Tinned copper wire	2C	HDPE	1.1	300V				
	Shielded			Jacket			Ambient temperature				
	Structure	Material	Coverage	Material	Dia. (mm)	Color					
Braids	Tinned copper wire	85%	PU	5.5	Black	-40°C~+80°C					

American Gauge AWG

AWG	Structure		Wire Max. Od		Wire Cross-Sections	
	Stranded Conductor No	Stranded Conductor AWG	(mm)	(in)	(mm ²)	(Square IN.)
0	259	24	11.277	0.444	52.90	0.0820
1	817	30	9.702	0.382	41.40	0.0641
2	259	26	8.89	0.35	33.20	0.0514
4	133	25	6.9596	0.274	21.5925	0.0335
6	133	27	5.5118	0.217	13.5885	0.0211
8	168	30	4.445	0.175	8.5127	0.0132
8	133	29	4.3942	0.173	8.6053	0.0133
10	105	30	3.3020	0.13	5.3204	0.0082
10	37	26	2.9210	0.115	4.7397	0.0073
10	1	10	2.6162	0.103	5.2614	0.0082
12	37	28	2.3114	0.091	2.9765	0.0046
12	19	25	2.3622	0.093	3.0847	0.0048
12 ¹⁾	7	20	2.5400	0.10	3.6321	0.0056
12	1	12	2.0828	0.082	3.3081	0.0051
14	41	30	2.0574	0.081	2.0775	0.0032
14	19	27	1.8542	0.073	1.9413	0.0030
14 ¹⁾	7	22	2.0828	0.082	2.2704	0.0035
14	1	14	1.6510	0.065	2.0820	0.0032
16 ¹⁾	65	34	1.5748	0.062	1.3072	0.0020
16	26	30	1.5748	0.062	1.3174	0.0020
16	19	29	1.4986	0.059	1.2293	0.0019
16 ¹⁾	7	24	1.5494	0.061	1.4330	0.0022
16	1	16	1.3208	0.052	1.3076	0.0020
18 ¹⁾	65	36	1.2700	0.05	0.8234	0.0013
18 ¹⁾	42	34	1.2700	0.05	0.8447	0.0013
18	19	30	1.3208	0.052	0.9627	0.0015
18	16	30	1.2954	0.051	0.8107	0.0013
18	7	26	1.2700	0.05	0.8967	0.0014

AWG	Structure		Wire Max. Od		Wire Cross-Sections	
	Stranded Conductor No	Stranded Conductor AWG	(mm)	(in)	(mm ²)	(Square IN.)
18	1	18	1.0414	0.041	0.8229	0.0013
20 ¹⁾	42	36	1.0160	0.04	0.5320	8.2×10 ⁻⁴
20	19	32	1.0414	0.041	0.6162	0.0010
20	10	30	1.0160	0.04	0.5067	7.9×10 ⁻⁴
20	7	28	0.9906	0.039	0.5631	8.7×10 ⁻⁴
20	1	20	0.8382	0.033	0.5189	8.0×10 ⁻⁴
22	19	34	0.8382	0.033	0.3821	5.9×10 ⁻⁴
22	7	30	0.7874	0.031	0.3547	5.5×10 ⁻⁴
22	1	22	0.6604	0.026	0.3243	5.0×10 ⁻⁴
24 ¹⁾	42	40	0.6604	0.026	0.2045	3.2×10 ⁻⁴
24	19	36	0.6858	0.027	0.2407	3.7×10 ⁻⁴
24	7	32	0.6350	0.025	0.2270	3.5×10 ⁻⁴
24	1	24	0.5588	0.022	0.2047	3.2×10 ⁻⁴
26	19	38	0.5588	0.022	0.1540	2.4×10 ⁻⁴
26	7	34	0.5080	0.02	0.1408	2.2×10 ⁻⁴
26	1	26	0.4318	0.017	0.1281	2.0×10 ⁻⁴
28 ¹⁾	19	40	0.4318	0.017	0.0925	1.4×10 ⁻⁴
28	7	36	0.4064	0.016	0.0887	1.4×10 ⁻⁴
28	1	28	0.3302	0.013	0.0804	1.2×10 ⁻⁴
30	7	38	0.3302	0.013	0.0568	8.8×10 ⁻⁵
30	1	30	0.2794	0.011	0.0507	7.9×10 ⁻⁵
32	7	40	0.2794	0.011	0.0341	5.3×10 ⁻⁵
32	1	32	0.2286	0.009	0.0324	5.0×10 ⁻⁵
34	1	34	0.1693	0.007	0.0201	3.1×10 ⁻⁵
36	1	36	0.127	0.005	0.0127	2.0×10 ⁻⁵
38	1	38	0.1016	0.004	0.0081	1.3×10 ⁻⁵
40	1	40	0.078	0.003	0.0049	7.5×10 ⁻⁶

Note: 1) Not included in the standard

Max. Rated Current Of Conductor

Test data based on ambient temperature of 30 ° C (refer to sections VDE0100.430 and 532 and other VDE regulations)

Standard cross-sectional area mm ²	Group 2 Max. current (A)	Group 3 Max. current (A)	Standard cross-sectional area mm ²	Group 2 Max. current (A)	Group 3 Max. current (A)	Standard cross-sectional area mm ²	Group 2 Max. current (A)	Group 3 Max. current (A)
0.08	1.0	1.5	0.34	6.0	8.0	1.00	15.0	19.0
0.14	2.0	3.0	0.50	9.0	12.0	1.50	18.0	24.0
0.25	4.0	5.0	0.75	12.0	15.0	2.50	26.0	32.0

The group 2 of multi-core conductors, such as solid core cable with outer leather, shielded cable, lead leather cable.....

The group 3 of single-core conductors and single-core cables shall be laid in an air environment with a spacing of at least one time of diameter

■ Cable Assembly Cable Stripping Lengths

■ B series

Series	Pin Count(P/N)	Straight Socket and Plug						90 Right Angled Socket																				
		Solder Contacts			Crimp Contacts			Solder Contacts			Crimp Contacts																	
		L(mm)	S(mm)	T(mm)	L(mm)	S(mm)	T(mm)	L(mm)	S(mm)	T(mm)	L(mm)	S(mm)	T(mm)															
00	302/303/304	7.0	4	2.5	10.0	4	3.0	9.5	4	2.5	12.5	4	3.0															
0B ¹⁾	302/303	13.0	7	3.0	17.0	7	4.0	18.0	7	3.0	22.0	7	4.0															
	304/305	13.0	7	3.0	17.0	7	4.0	18.0	7	3.0	22.0	7	4.0															
	306/307/309	12.5	7	2.5	18.0	7	3.0	19.0	7	2.5	23.0	7	3.0															
1B ¹⁾	302/303	14.0	8	3.5	18.0	8	4.0	25.0	8	3.5	28.0	8	4.0															
	304/305	14.0	8	3.0	18.0	8	4.0	25.0	8	3.0	28.0	8	4.0															
	306/307/308	14.0	8	3.0	18.0	8	4.0	25.0	8	3.0	28.0	8	4.0															
	310/314/316	13.5	8	2.5	-	-	-	27.5	8	2.5	-	-	-															
2B	302	16.0	9	4.0	22.0	9	5.5	30.0	9	4.0	33.0	9	5.5															
	303	16.0	9	3.5	22.0	9	5.5	30.0	9	3.5	33.0	9	5.5															
	304/305/306/307	16.0	9	3.5	20.0	9	4.0	29.0	9	3.5	31.0	9	4.0															
	308/310	15.0	9	3.0	20.0	9	4.0	28.0	9	3.0	31.0	9	4.0															
	312/314/316/318/319	15.0	9	3.0	20.0	9	4.0	28.0	9	3.0	31.0	9	4.0															
	326/332	15.0	9	2.5	-	-	-	28.0	9	2.5	-	-	-															
3B	302	24.0	10	4.5	28.0	10	5.5	35.0	10	4.5	39.0	10	5.5															
	303/304	23.0	10	4.0	27.0	10	5.5	34.0	10	4.0	38.0	10	5.5															
	305/306/307	23.0	10	3.5	27.0	10	5.5	34.0	10	3.5	38.0	10	5.5															
	308/310	22.0	10	3.5	25.0	10	4.0	33.0	10	3.5	36.0	10	4.0															
	309	<table border="1"> <tr> <td>Ø1.3</td> <td>22.0</td> <td>10</td> <td>3.5</td> <td>25.0</td> <td>10</td> <td>4.0</td> <td>33.0</td> <td>10</td> <td>3.5</td> <td>36.0</td> <td>10</td> <td>4.0</td> </tr> <tr> <td>Ø2.0</td> <td>22.0</td> <td>10</td> <td>4.0</td> <td>25.0</td> <td>10</td> <td>5.5</td> <td>33.0</td> <td>10</td> <td>4.0</td> <td>36.0</td> <td>10</td> <td>5.5</td> </tr> </table>	Ø1.3	22.0	10	3.5	25.0	10	4.0	33.0	10	3.5	36.0	10	4.0	Ø2.0	22.0	10	4.0	25.0	10	5.5	33.0	10	4.0	36.0	10	5.5
	Ø1.3		22.0	10	3.5	25.0	10	4.0	33.0	10	3.5	36.0	10	4.0														
	Ø2.0	22.0	10	4.0	25.0	10	5.5	33.0	10	4.0	36.0	10	5.5															
312/314/316/318	21.0	10	3.0	25.0	10	4.0	32.0	10	3.0	36.0	10	4.0																
320/322/324/326/330	21.0	10	3.0	25.0	10	4.0	32.0	10	3.0	36.0	10	4.0																
4B	304	33.0	12	4.5	36.0	12	5.5	41.0	12	4.5	45.0	12	5.5															
	306/307	32.0	12	4.0	36.0	12	5.5	41.0	12	4.0	45.0	12	5.5															
	310	32.0	12	3.5	36.0	12	5.5	39.0	12	3.5	43.0	12	5.5															
	312	32.0	12	3.5	36.0	12	4.0	39.0	12	3.5	43.0	12	4.0															
	316/320/324/330	32.0	12	3.0	34.0	12	4.0	39.0	12	3.0	43.0	12	4.0															
	340/348	32.0	12	3.0	34.0	12	4.0	39.0	12	3.0	43.0	12	4.0															

Note:

- 1) In 0B and 1B series, <L> and <S> dimensions shall be increased by 2mm for largest collet(D56 in 0B series, D76 in 1B series)
- 2) For the central contacts, the wires shall be reduced by 1.5~2.0mm
- 3) the tolerances on these dimensions are. L:±0.5mm, S:±0.5mm, T±0.2mm

■ K series

Series	Pin Count(P/N)	Straight Socket and Plug						90 Right Angled Socket					
		Solder Contacts			Crimp Contacts			Solder Contacts			Crimp Contacts		
		L(mm)	S(mm)	T(mm)	L(mm)	S(mm)	T(mm)	L(mm)	S(mm)	T(mm)	L(mm)	S(mm)	T(mm)
0K	302/303	9.5	6	3.0	12.0	6	4.0	21.0	6	3.0	25.0	6	4.0
	304/305	9.5	6	3.0	12.0	6	4.0	21.0	6	3.0	25.0	6	4.0
	306/307/309	9.0	6	2.5	13.0	6	4.0	22.0	6	2.5	26.0	6	4.0
1K	302/303	10.5	7	3.5	14.5	7	4.0	27.0	7	3.5	31.0	7	4.0
	304/305	10.5	7	3.0	14.5	7	4.0	27.0	7	3.0	31.0	7	4.0
	306/307/308	10.5	7	3.0	14.5	7	4.0	27.0	7	3.0	31.0	7	4.0
	310/314/316	13.0	7	2.5	-	-	-	29.5	7	2.5	-	-	-

■ Cable Assembly Cable Stripping Lengths

■ K series

Series	Pin Count(P/N)	Straight Socket and Plug						90 Right Angled Socket						
		Solder Contacts			Crimp Contacts			Solder Contacts			Crimp Contacts			
		L(mm)	S(mm)	T(mm)	L(mm)	S(mm)	T(mm)	L(mm)	S(mm)	T(mm)	L(mm)	S(mm)	T(mm)	
2K	302	16.5	8	4.0	19.5	8	5.5	36.0	8	4.0	39.0	8	5.5	
	303	16.5	8	3.5	19.5	8	5.5	36.0	8	3.5	39.0	8	5.5	
	304/305/306/307	15.5	8	3.5	17.5	8	4.0	35.0	8	3.5	37.0	8	4.0	
	308/310	14.5	8	3.0	17.5	8	4.0	34.0	8	3.0	37.0	8	4.0	
	312/314/316/318/319	14.5	8	3.0	17.5	8	4.0	34.0	8	3.0	37.0	8	4.0	
	326/332	14.5	8	2.5	-	-	-	34.0	8	2.5	-	-	-	
3K	302	19.0	10	4.5	23.0	10	5.5	48.0	10	4.5	53.0	10	5.5	
	303/304	18.0	10	4.0	22.0	10	5.5	48.0	10	4.0	52.0	10	5.5	
	305/306/307	18.0	10	3.5	22.0	10	5.5	48.0	10	3.5	52.0	10	5.5	
	308/310	17.0	10	3.5	20.0	10	4.0	47.0	10	3.5	50.0	10	4.0	
	309	$\begin{matrix} \text{Ø1.3} \\ \text{Ø2.0} \end{matrix}$	17.0	10	3.5	20.0	10	4.0	47.0	10	3.5	50.0	10	4.0
	4.0				5.5			4.0			5.5			
	312/314/316/318	16.0	10	3.0	20.0	10	4.0	46.0	10	3.0	50.0	10	4.0	
320/322/324/326/330	16.0	10	3.0	20.0	10	4.0	46.0	10	3.0	50.0	10	4.0		
4K	304	22.0	11	4.5	25.0	11	5.5	52.0	11	4.5	55.0	11	5.5	
	306/307	21.0	11	4.0	25.0	11	5.5	51.0	11	4.0	55.0	11	5.5	
	310	21.0	11	3.5	25.0	11	5.5	51.0	11	3.5	55.0	11	5.5	
	312	21.0	11	3.5	25.0	11	4.0	51.0	11	3.5	55.0	11	4.0	
	316/320/324/330	21.0	11	3.0	23.0	11	4.0	51.0	11	3.0	53.0	11	4.0	
	340/348	21.0	11	3.0	23.0	11	4.0	51.0	11	3.0	53.0	11	4.0	

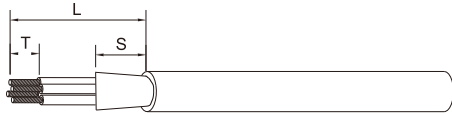

Note:
For the central contacts, the wires shall be reduced by 1.5~2.5mm
The tolerance:
L:±0.5mm; S:±0.5mm; T:±0.2mm.

■ K Series (Stright plug and stright socket with oversize cable collet)

Series	Pin Count(P/N)	90 Right Angled Socket					
		Solder Contacts			Crimp Contacts		
		L(mm)	S(mm)	T(mm)	L(mm)	S(mm)	T(mm)
1K	302/303	23.5	8	3.5	27.5	8	4.0
	304/305	23.5	8	3.0	27.5	8	4.0
	306/307/308	23.5	8	3.0	27.5	8	4.0
	310/314/316	24.5	8	2.5	-	-	-
2K	302	29.5	10	4.0	32.5	10	5.5
	303	29.5	10	3.5	32.5	10	5.5
	304/305/306/307	28.5	10	3.5	30.5	10	4.0
	308/310	27.5	10	3.0	30.5	10	4.0
	312/314/316/318/319	27.5	10	3.0	30.5	10	4.0
	326/332	27.5	10	2.5	-	-	-
3K	302	37.0	11	4.5	41.0	11	5.5
	303/304	36.0	11	4.0	40.0	11	5.5
	305/306/307	36.0	11	3.5	40.0	11	5.5
	308/310	35.0	11	3.5	38.0	11	4.0
	309	34.0	11	3.0	38.0	11	4.0
	5.5						
	312/314/316/318	34.0	11	3.0	38.0	11	4.0
320/322/324/326/330	34.0	11	3.0	38.0	11	4.0	

■ Cable Assembly Cable Stripping Lengths

■ K Series (Stright plug and stright socket with oversize cable collet)

Series	Pin Count(P/N)	90 Right Angled Socket					
		Solder Contacts			Crimp Contacts		
		L(mm)	S(mm)	T(mm)	L(mm)	S(mm)	T(mm)
4K	306/307	44.0	14	4.0	48.0	14	5.5
	310	44.0	14	3.5	48.0	14	5.5
	312	44.0	14	3.5	48.0	14	4.0
	316/320/324/330	44.0	14	3.0	46.0	14	4.0
	340/348	44.0	14	3.0	46.0	14	4.0

Note:
For the central contacts, the wires shall be reduced by 1.5~2.5mm
The tolerance:
L:±0.5mm; S:±0.5mm; T:±0.2mm.

■ T series

Series	Pin Count(P/N)	Solder Contacts			Crimp Contacts		
		L(mm)	S(mm)	T(mm)	L(mm)	S(mm)	T(mm)
TT	302/303/304	7.0	4.0	2.5	10.0	4.0	3.0
	305/306	7.0	4.0	2.5	-	-	-
0T	302/303	9.5	6.0	3.5	12.0	6.0	4.0
	304/305	9.5	6.0	3.5	12.0	6.0	4.0
	1) 306/307/309	9.0	6.0	2.5	13.0	6.0	3.0
	312	9.0	6.0	2.5	-	-	-
1T	302/303	11.0	7	3.5	14.5	7	4.0
	304/305	11.0	7	3.0	14.5	7	4.0
	306/307/308	11.0	7	3.0	14.5	7	4.0
	310/314/316	13.0	7	2.5	-	-	-
3T	302	16.5	8	4.0	19.5	8	5.5
	303	16.5	8	3.5	19.5	8	5.5
	304/305/306/307	15.5	8	3.5	17.5	8	4.0
	308/310	14.5	8	3.0	17.5	8	4.0
	312/314/316/318/319	14.5	8	3.0	17.5	8	4.0
	326/332	14.5	8	2.5	-	-	-

Note:
1) Crimp contacts are available only for connectors fitted with male contacts
2) The tolerances on these dimensions are. L:±0.5mm; S:±0.5mm; T:±0.2mm

■ Cable Assembly Cable Stripping Lengths

■ S series

Series	Pin Count(P/N)	Straight Socket and Plug						90 Right Angled Socket					
		Solder Contacts			Crimp Contacts			Solder Contacts			Crimp Contacts		
		L(mm)	S(mm)	T(mm)	L(mm)	S(mm)	T(mm)	L(mm)	S(mm)	T(mm)	L(mm)	S(mm)	T(mm)
0S	302	10	5	4.0	15	5	4.0	10	5	4.0	15	5	4.0
	303/304	10	5	4.0	15	5	4.0	10	5	4.0	15	5	4.0
1S	302	13	8	3.0	17	8	4.0	13	8	3.0	17	8	4.0
	303/304	13	8	3.0	17	8	4.0	13	8	3.0	17	8	4.0
	305	13	8	3.0	17	8	4.0	13	8	3.0	17	8	4.0
		13	8	2.5	17	8	4.0	13	8	2.5	17	8	4.0
306	13	8	2.5	17	8	4.0	13	8	2.5	17	8	4.0	
2S	302	18	9	4.5	22	9	5.5	18	9	4.5	22	9	5.5
	303/304/305/306	18	9	4.0	22	9	4.0	18	9	4.0	22	9	4.0
	307	18	9	4.0	22	9	4.0	18	9	4.0	22	9	4.0
		18	9	4.0	22	9	4.0	18	9	4.0	22	9	4.0
308/310	18	9	4.0	22	9	4.0	18	9	4.0	22	9	4.0	

■ E series

Series	Pin Count(P/N)	Solder Contacts		
		L(mm)	S(mm)	T(mm)
0E	302	9.0	4.0	3.5
	303/304	9.0	4.0	3.5
1E	302	10.5	6.0	3.5
	303/304	10.5	6.0	3.0
	305	10.5	6.0	3.0
	306	10.5	6.0	3.0
2E	302	14.0	9.0	3.5
	303/304/305/306	14.5	9.0	3.5
	307	14.5	9.0	3.5/3.0
	308/310	14.0	9.0	3.0



Note:
1) The tolerances on these dimensions are. L: $\pm 0.5\text{mm}$; S: $\pm 0.5\text{mm}$; T: $\pm 0.2\text{mm}$

■ L series

Series	Pin Count(P/N)	Solder Contacts		
		L(mm)	S(mm)	T(mm)
0L	302	11.0	6.0	3.5
	303/304	11.5	6.0	3.5
1L	302	13.0	7.0	3.5
	303/304	12.5	7.0	3.0
	305	12.5	7.0	3.0
	306	13.0	7.0	3.0
2L	302	17.0	8.0	3.5
	303/304/305/306	16.5	8.0	3.5
	307	16.5/15.0	8.0	3.5/3.0
	308/310	15.0	8.0	3.0



Note:
1) The tolerances on these dimensions are. L: $\pm 0.5\text{mm}$; S: $\pm 0.5\text{mm}$; T: $\pm 0.2\text{mm}$

■ Cable Assembly Cable Stripping Lengths

■ P series

Series	Pin Count(P/N)	L(mm)	T(mm)
1P	302	14.0	4.0
	304/305	13.0	3.0
	306/307/308/309/310/314	12.5	2.5
2P	302	19.0	4.0
	303	19.0	3.5
	304/305/306/307	18.0	3.5
	308/310/312/316/319	17	3.0
	326/332	17	2.5



Note:

- 1) For the central contacts, the wires shall be reduced by 1.5~2.0mm
- 2) the tolerances on these dimensions are: L: ±0.5mm, T ±0.2mm

Water Tight Or Vacuum Sealed Type

This type of socket and dual - way type can make the device to IP68 protection rating (according to IEC60529 standard). They are fully compatible with the same series of plugs, so they are widely used in portable wireless devices, military, experimental equipment and aviation fields.

These types are distinguished by a letter "P" at the end of the product number.

Most of these models have a vacuum seal. For vacuum sealed types, add a letter "V" after the letter "P".

The sealing material of this type is epoxy resin.

Technical Characteristics

Mechanical and climatical

Characteristics	Value	Standard
Endurance	>5000 cycles	IEC60512- 5 test 9a
Humidity	up to 95% at 60°C	-
Temperature range(0S to 1S)	-20°C, +100°C	-
Temperature range(2S to 6S)	-20°C, +80°C	-
Salt spray corrosion test	>144h	IEC60512-6 test 11f
Climatical category	20/80/21	IEC60068-1
Leakage rate (He) ¹⁾	10 ⁻⁷ mbar.l.s ⁻¹	IEC60512-7 test 14b

Note: 1)only for vacuumtight models.

Characteristics	Value	Standard
Maximum operating pressure ²⁾	0S	60 bars
	1S	60 bars
	2S	40 bars
	3S	30 bars
	4S	15 bars
	5S	5 bars
6S	5 bars	IEC60512-7 test 14d

Note :2)this value corresponds to the maximum allowed pressure difference for the assembled socket.

■ Bend Relief Functional Description

PS · G · 0B · 305 · C L A D 42 Z

Null=Not for Fitting Bend Relief
Z=Fitting Bend Relief (Part No. See Page 179)

■ Bend Relief Assembly

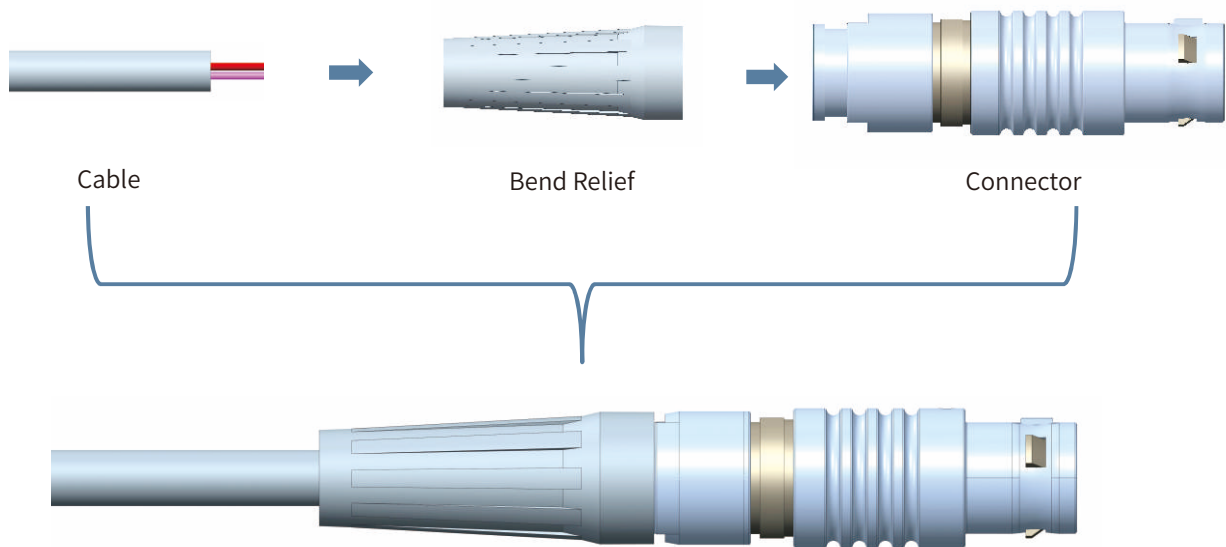

Assembly Drawing

Bend relief made from thermoplastic polyurethane elastomer. Can be fitted over plug and sockets that are supplied with nut for fitting such bend relief. They are available in nine different colours that match with the insulating washers.

■ Main Characteristics

Material: Polyurethane elastomer.

Temperature range in dry atmosphere: -40°C~+80°C; 105°C; 200°C.

■ SR. Bend Relief

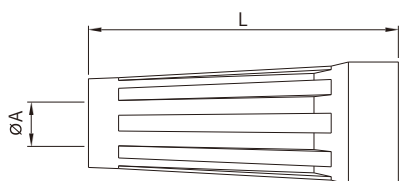

■ Main characteristics

- Material: TPU
- Temperature range in dry atmosphere: -40°C +80°C

Part number	Dimensions (mm)				Series
	Bend relief		Cable Ø		
	A	L	max.	min.	
SRA.00.012.G	1.2	22	1.4	1.1	00
SRA.00.018.G	1.8	22	2.1	1.8	
SRA.00.025.G	2.5	22	2.8	2.5	
SRA.00.028.G	2.8	22	3.1	2.8	
SRA.00.032.G	3.2	22	3.5	3.2	
SRA.0B.025.G	2.5	24	2.9	2.5	
SRA.0B.030.G	3.0	24	3.4	3.0	
SRA.0B.035.G	3.5	24	3.9	3.5	
SRA.0B.040.G	4.0	24	4.4	4.0	
SRA.0B.045.G	4.5	24	5.2	4.5	
SRA.1B.025.G	2.5	30	2.9	2.5	1B,1K 1S,1P 1T
SRA.1B.030.G	3.0	30	3.4	3.0	
SRA.1B.035.G	3.5	30	3.9	3.5	
SRA.1B.040.G	4.0	30	4.4	4.0	

Part number	Dimensions (mm)				Series
	Bend relief		Cable Ø		
	A	L	max.	min.	
SRA.1B.045.G	4.5	30	4.9	4.5	1B,1K 1S,1P 1T
SRA.1B.054.G	5.4	30	6.0	5.4	
SRA.1B.065.G	6.5	30	7.0	6.5	
SRA.2B.040.G	4.0	36	4.5	4.0	2B,1K 2S,2P 2T
SRA.2B.045.G	4.5	36	5.0	4.5	
SRA.2B.050.G	5.0	36	5.5	5.0	
SRA.2B.060.G	6.0	36	6.5	6.0	
SRA.2B.070.G	7.0	36	7.7	7.0	
SRA.2B.080.G	7.8	36	8.8	7.8	
SRA.3B.050.G	4.5	42	5.2	4.5	3B,3K 3S 3T
SRA.3B.060.G	6.0	42	6.9	6.0	
SRA.3B.070.G	7.0	42	7.9	7.0	
SRA.3B.080.G	8.0	42	8.9	8.0	
SRA.3B.090.G	9.0	42	10.0	9.0	

■ Colour Coding

This colour coding table is for (SR) bend relief and plastic collet nut.

	Colours						
	grey	blue	yellow	black	red	green	white
Reference	G	L	Y	B	R	N	W

■ B/T/250/R Series

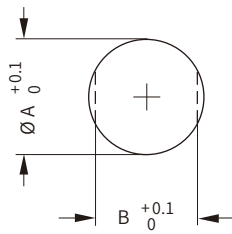

Panel cut-outs

Series	ØA	B
00/TT	7.1	6.4
00 (1)	7.1	0
0B/0T	9.1	8.3
0B (1)	9.1	0
1B	12.1	10.6
1B (1)	11.1	0
2B	15.1	13.6
3B	18.2	16.6
4B	25.2	23.6

Mounting nut torque

Series	Torque(Nm)
00/TT	1.0
0B/0T	2.5
1B/1T	4.5
2B/2T	6.0
3B/3T	9.0
4B/4T	12.0

1N=0.102kg

Note: (1) only for FXG (B series)

■ K/E/L Series

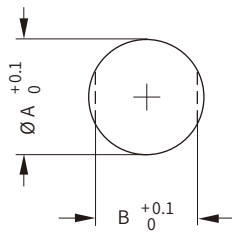

Panel cut-outs

Series	ØA	B
0K/0E/0L	14.1	12.6
1K/1E/1L	16.1	14.6
2K/2E/2L	20.2	18.6
3K/3E/3L	24.2	22.6
4K/4E/4L	30.2	28.6

Mounting nut torque

Series	Torque(Nm)
0K/0E/0L	5.0
1K/1E/1L	7.0
2K/2E/2L	9.0
3K/3E/3L	12.0
4K/4E/4L	17.0

1N=0.102kg

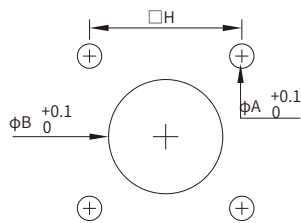

P1

Series	ØA	B	H
3K	3.5	22.6	20.6
4K	3.5	28.6	27

P2

Series	ØA	B	H
3K	3.5	23.1	23.0
4K	3.5	30.1	29.0

■ S series

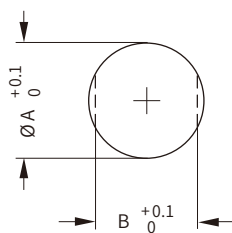

Panel cut-outs

Series	ØA	B
0S	9.1	8.3
1S	12.1	10.6
2S	15.1	13.6

Mounting nut torque

Series	Torque(Nm)
0S	2.5
1S	4.5

1N=0.102kg

■ P series

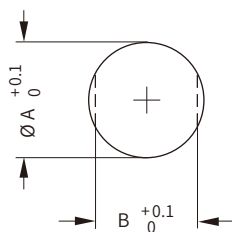

Panel cut-outs

Series	ØA	B
1P	14.1	12.6
2P	17.1	15.6

Mounting nut torque

Series	Torque(Nm)
1P	1.5
2P	0.8

1N=0.102kg

■ Angled(90°) Socket For Printed Circuit (FXG-B Series)

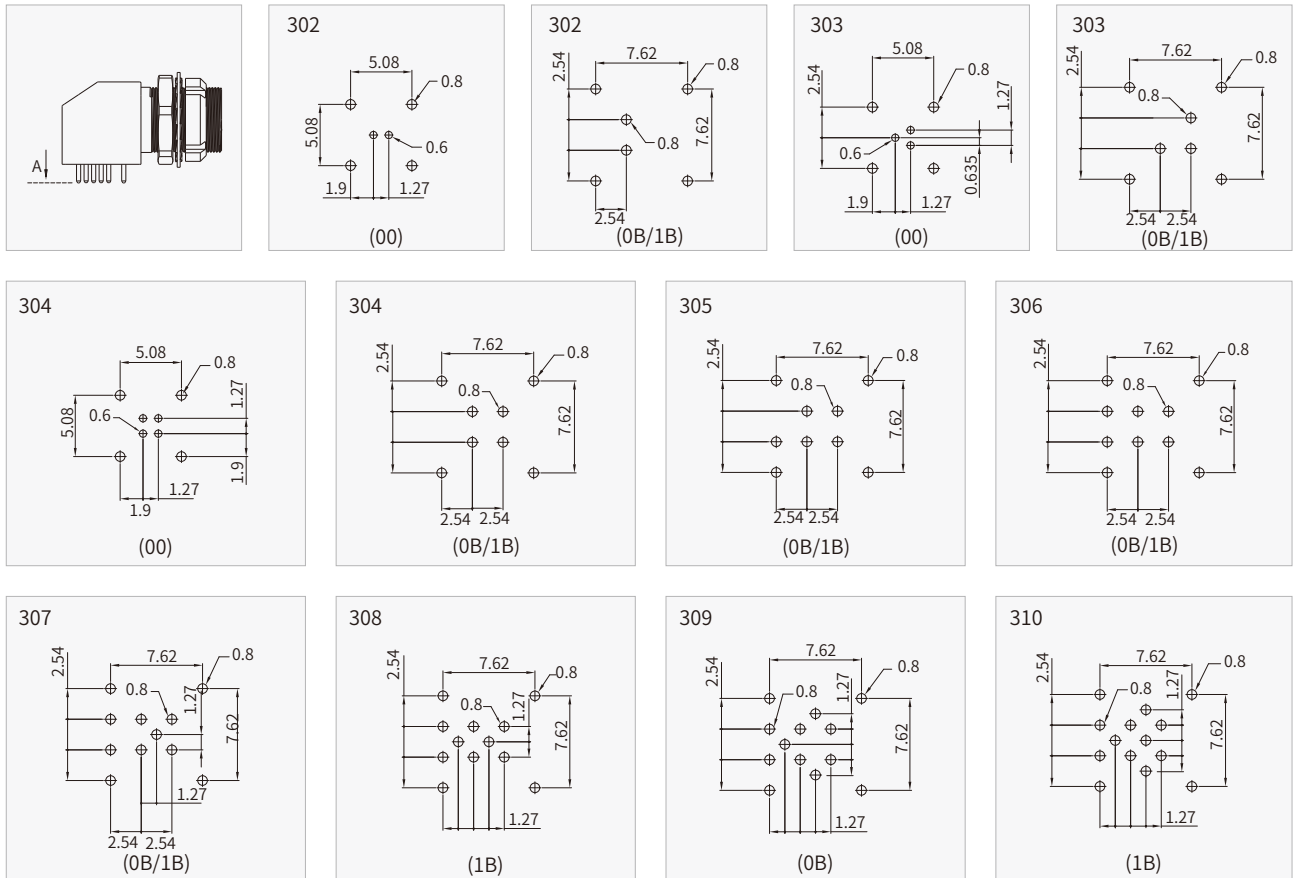

■ 1P PCB drilling pattern (for straight contacts)

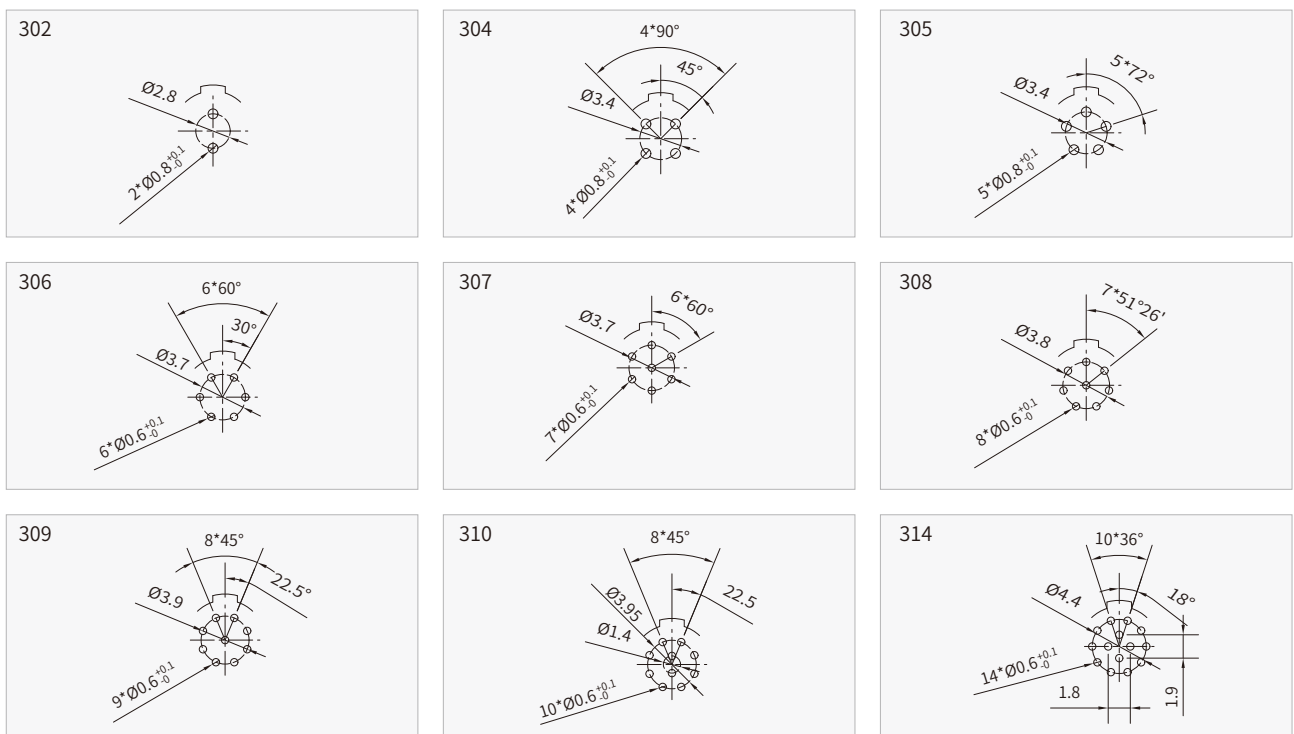

■ 2P PCB Drilling Pattern (for Straight Contacts)

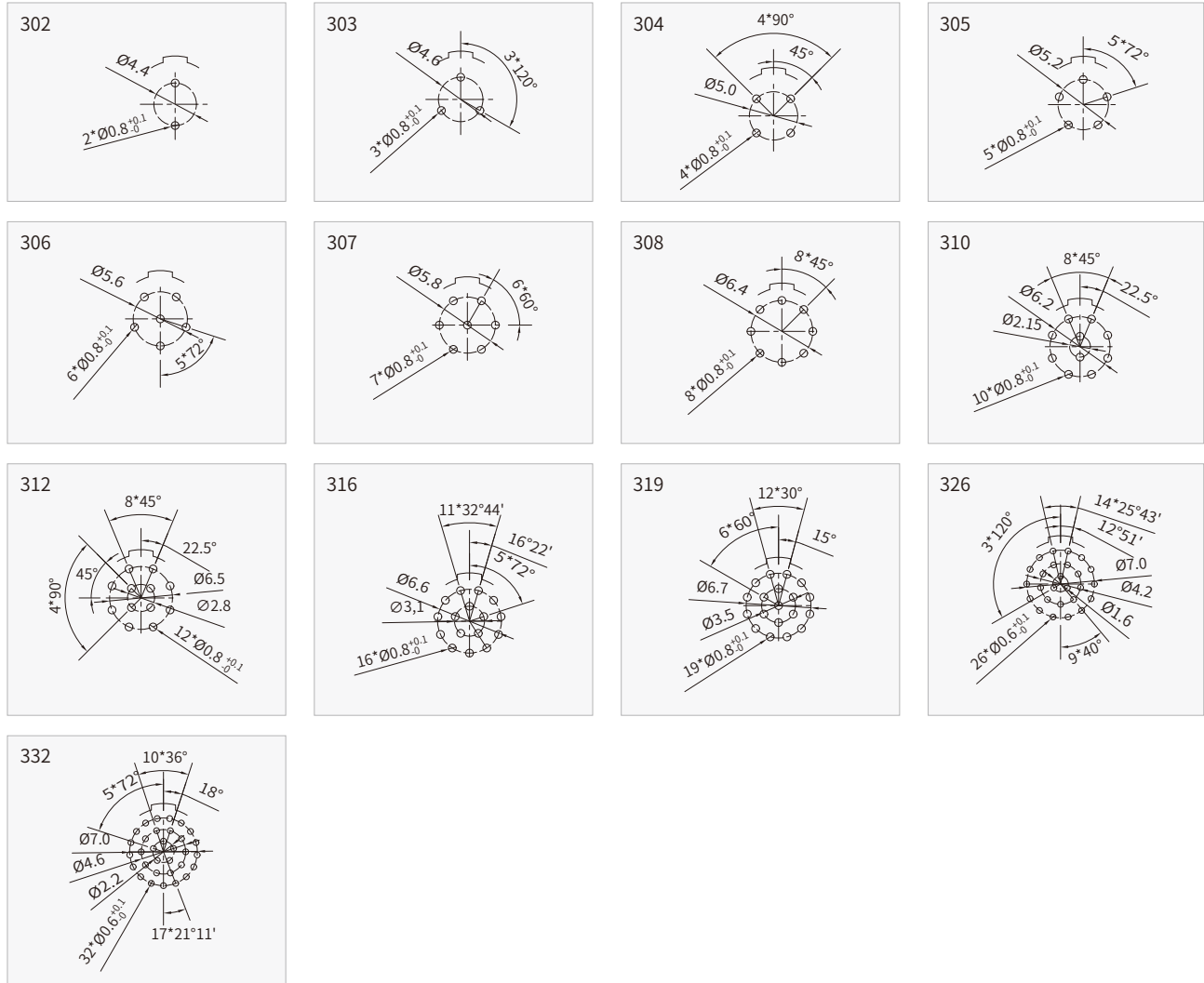

1P PCB drilling pattern (for 90° elbow contacts)

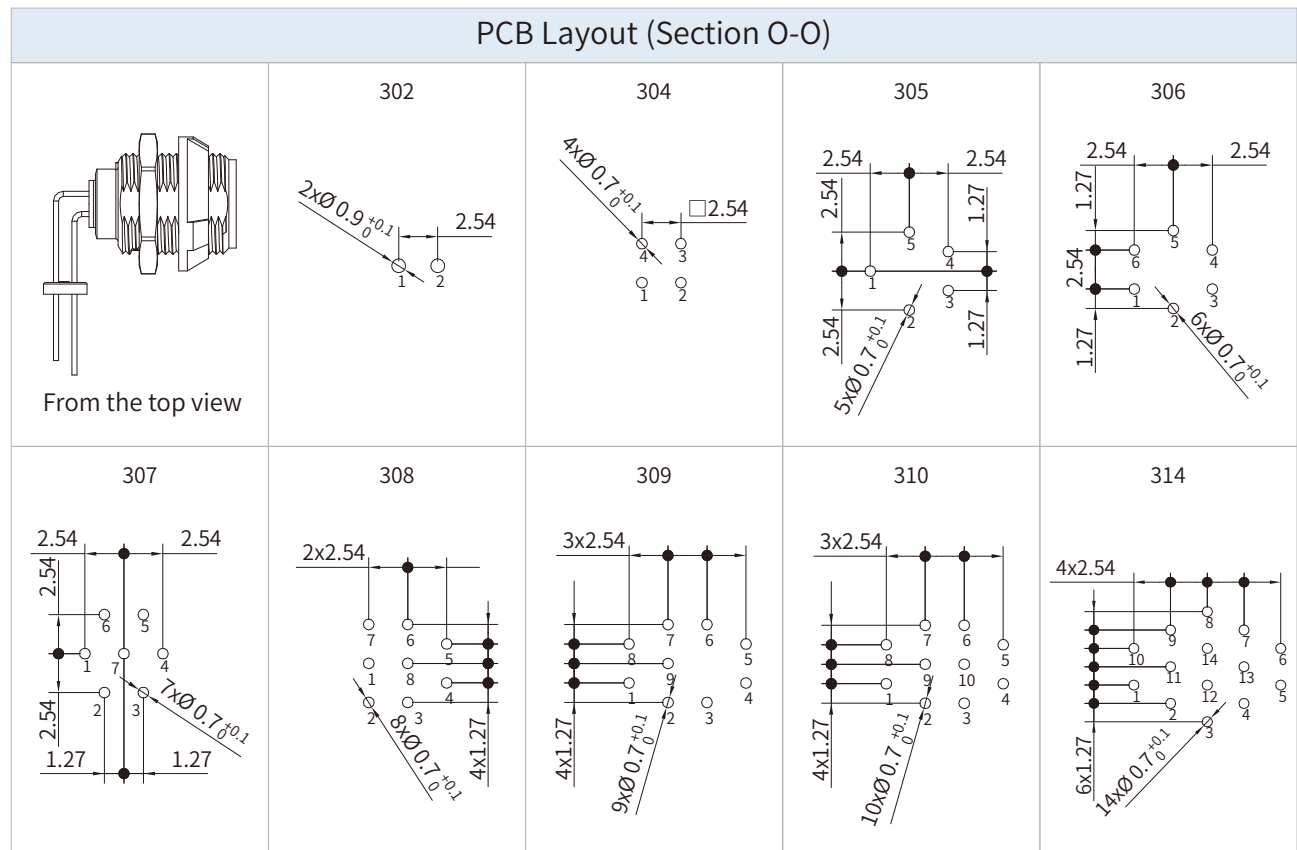

Collet



Series	Reference		Collet ID(mm)		Cable OD(mm)	
	Type	Code	Ø A	Ø B	Max.	Min.
1P	C	39	4.0	-	3.9	2.7
	C	52	5.3	-	5.2	4.0
	C	65	6.6	-	6.5	5.3
2P	C	52	5.3	-	5.2	3.2
	C	72	7.3	-	7.2	5.3
	C	92	9.3	-	9.2	7.3

Fixed Socket With Straight Print Contact (B-K Series) (From the top view)

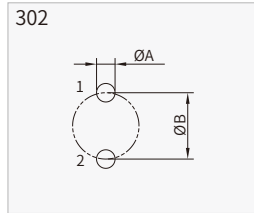

Series	Dimensions(mm)	
	A	B
00-TT	0.6	1.2
0B-0K-0T	0.8	2.2
1B-1K-1T	0.8	2.8
2B-2K-2T	0.8	4.4

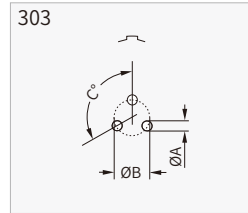

Series	Dimensions(mm)		
	A	B	C
00	0.6	1.35	120°
0B-0K	0.8	2.30	120°
1B-1K	0.8	3.00	120°
2B-2K	0.8	4.60	120°
3B-3K	0.8	5.60	120°

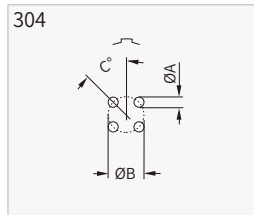

Series	Dimensions(mm)		
	A	B	C
00	0.6	1.6	45°
0B-0K	0.6	2.5	45°
1B-1K	0.8	3.1	45°
2B-2K	0.8	5.0	45°
3B-3K	0.8	6.2	45°

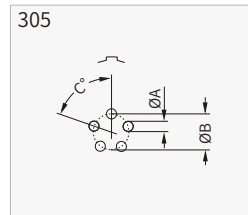

Series	Dimensions(mm)		
	A	B	C
0B-0K	0.6	2.8	72°
1B-1K	0.8	3.4	72°
2B-2K	0.8	5.2	72°
3B-3K	0.8	6.7	72°

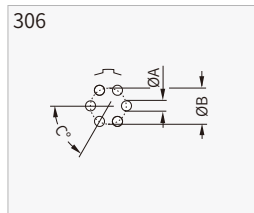

Series	Dimensions(mm)		
	A	B	C
0B-0K	0.6	3.0	60°
1B-1K	0.8	3.7	60°

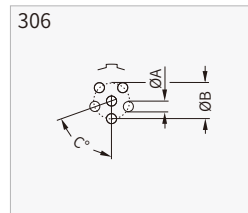

Series	Dimensions(mm)		
	A	B	C
2B-2K	0.8	5.6	72°
3B-3K	0.8	7.1	72°

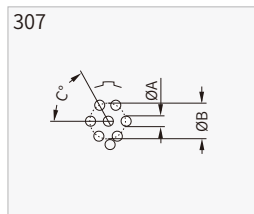

Series	Dimensions(mm)		
	A	B	C
0B-0K	0.6	3.00	60°
1B-1K	0.8	3.70	60°
2B-2K	0.8	5.80	60°
3B-3K	0.8	7.08	60°

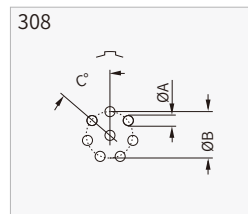

Series	Dimensions(mm)		
	A	B	C
1B-1K	0.8	3.8	51°26'

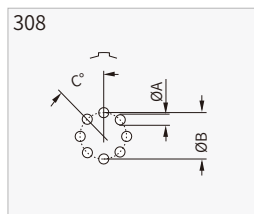

Series	Dimensions(mm)		
	A	B	C
2B-2K	0.8	6.4	45°
3B-3K	0.8	7.5	45°

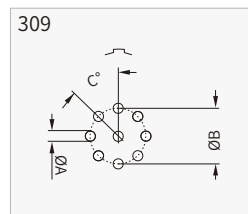

Series	Dimensions(mm)		
	A	B	C
0B-0K	0.6	3.2	45°
3B-3K	0.8	7.5	45°

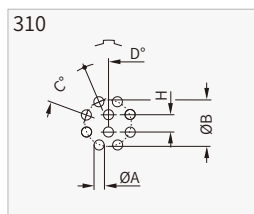

Series	Dimensions(mm)				
	A	B	C	D	H
1B-1K	0.6	3.95	45°	22°30'	1.4
2B-2K	0.8	6.20	45°	22°30'	2.15
3B-3K	0.8	7.90	45°	22°30'	2.80

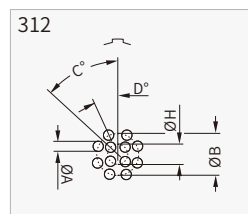

Series	Dimensions(mm)				
	A	B	C	D	H
2B-2K	0.8	6.5	45°	22°30'	2.8
3B-3K	0.8	8.2	45°	22°30'	3.4

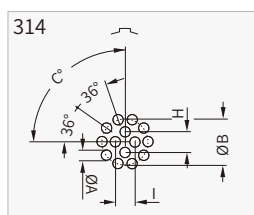

Series	Dimensions(mm)				
	A	B	C	H	I
1B-1K	0.6	4.4	90°	1.90	1.80
2B-2K	0.8	6.5	90°	2.65	2.65
3B-3K	0.8	8.2	90°	3.40	3.40

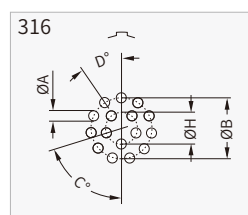

Series	Dimensions(mm)				
	A	B	C	D	H
1B-1K	0.6	4.4	72°	32°44'	2.0

Fixed Socket With Straight Print Contact (B-K Series) (From the top view)

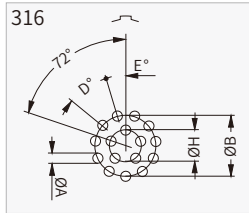

Series	Dimensions(mm)				
	A	B	D	E	H
2B-2K	0.8	6.6	32°44'	16°22'	3.10
3B-3K	0.8	8.4	32°44'	16°22'	3.86

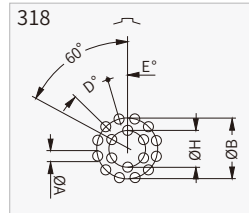

Series	Dimensions(mm)				
	A	B	D	E	H
2B-2K	0.8	6.7	30°	15°	3.50
3B-3K	0.8	8.4	30°	15°	4.34

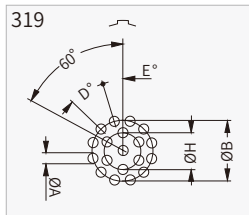

Series	Dimensions(mm)				
	A	B	D	E	H
2B-2K	0.8	6.7	30°	15°	3.5

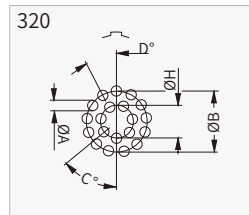

Series	Dimensions(mm)				
	A	B	C	D	H
3B-3K	0.6	8.62	51°26'	27°42'	4.78

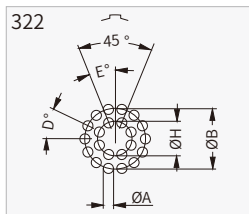

Series	Dimensions(mm)				
	A	B	D	E	H
3B-3K	0.6	8.8	25°43'	1.8	5.30

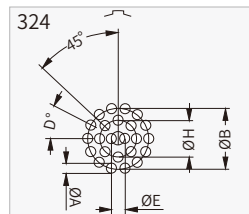

Series	Dimensions(mm)				
	A	B	D	E	H
3B-3K	0.6	8.8	25°43'	1.8	5.30

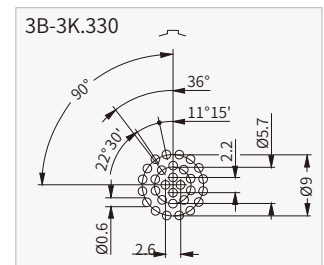
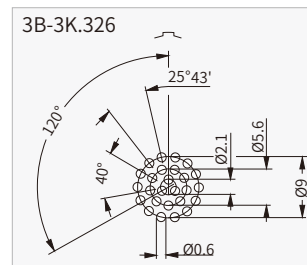
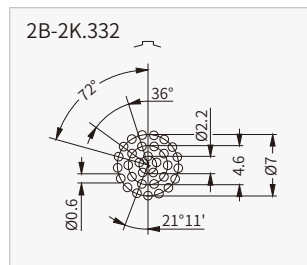
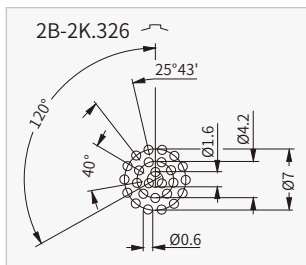

Length of straight print contacts (for socket)

Series	Type	Dim.(mm)	
		Ø C	L
00	302/303/304	0.5	3.0
0B/0K/0T	302/303	0.7	3.2
	304/305/306/307/309	0.5	3.2
1B/1K/1T	302/303/304/305/306/307/308	0.7	3.0
	310/314/316	0.5	4.0
2B/2K/2T	302/303/304/305/306/307	0.7	3.0
	308/310/312/314/316/318/319	0.7	3.0
3B/3K/3T	326/332	0.5	3.0
	303/304/305/306/307/308/309	0.7	3.0
3B/3K/3T	310/312/314/316/318	0.7	3.0
	320/322/324/326/330/332	0.5	5.0

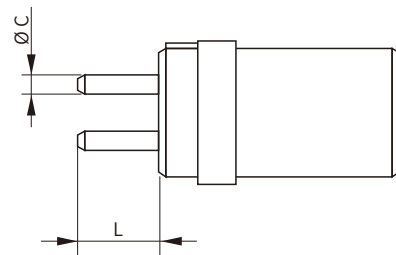

Fixed Socket With Elbow Print Contact (B-K Series) (From the top view)

302		Series	Dim.(mm)	
			A	
		00	0.6	
		0B-0K	0.7	
1B-1K	0.9			
2B-2K	0.9			

303		Series	Dim.(mm)	
			A	L
		00	0.6	1.27
		0B-0K	0.7	1.27
1B-1K	0.9	1.27		
2B-2K	0.9	2.54		

304		Series	Dim.(mm)	
			A	L
		00	0.6	2.54
		0B-0K	0.7	2.54
		1B-1K	0.7	2.54
2B-2K	0.9	3.50		
3B-3K	0.9	2.54		

0B-0K.305	1B-1K.305	2B-2K.305	0B-0K / 1B-1K.306
2B-2K / 3B-3K.306	0B-0K / 1B-1K.307	2B-2K.307	1B-1K.308
2B-2K / 3B-3K.308	1B-1K / 2B-2K / 3B-3K.310	2B-2K / 3B-3K.312	1B-1K / 2B-2K.314
3B-3K.314	2B-2K / 3B-3K.316	2B-2K.318	3B-3K.318
2B-2K.319	3B-3K.320	3B-3K.324	3B-3K.330

Fixed Socket With Straight Print Contact (S Series) (From the top view)

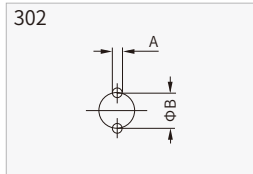

Series	Dimensions(mm)	
	A	B
0S	0.6	2.2
1S	0.8	3.0

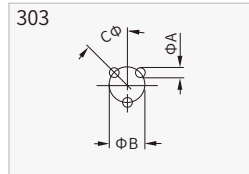

Series	Dimensions(mm)		
	A	B	C
0S	0.6	2.8	45°
1S	0.8	3.5	60°
2S	0.8	5.5	60°

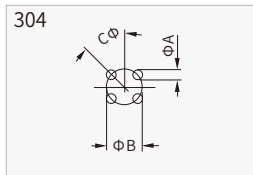

Series	Dimensions(mm)		
	A	B	C
0S	0.6	2.8	45°
1S	0.8	3.5	45°
2S	0.8	5.0	45°

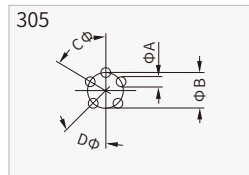

Series	Dimensions(mm)			
	A	B	C	D
1S	0.8	3.5	60°	45°
2S	0.8	5.5	60°	60°

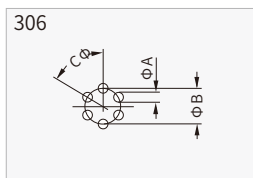

Series	Dimensions(mm)		
	A	B	C
1S	0.8	3.5	60°
2S	0.8	5.5	60°

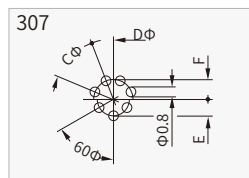

Series	Dimensions(mm)			
	C	D	E	F
2S	45°	22°30'	2.75	3.25

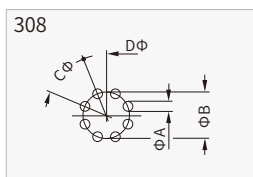

Series	Dimensions(mm)			
	A	B	C	D
2S	0.8	6.5	45°	22°30'

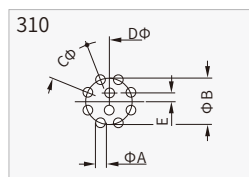

Series	Dimensions(mm)				
	A	B	C	D	E
2S	0.8	6.5	45°	22°30'	1.25

Length of straight print contacts (for socket)

Series	Type	Dim.(mm)	
		Ø C	L
0S/0E	302	0.7	3.0
	303	0.5	3.0
	304	0.5	3.0
1S/1E	302	0.7/1.5	3.0/5.0
	303/304/305	0.7	3.0
	305/306	0.5	3.0
2S/2E	303/304/305	0.7	3.0
	306/307	0.7	3.0
	308/310	0.7	3.0

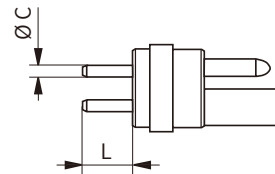

00 Coaxial Series PCB drilling pattern

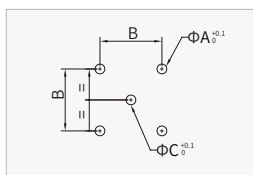

Series	Dimensions(mm)		
	ΦA	B	C
FAA,FAB,FAP	0.8	5.08	0.8

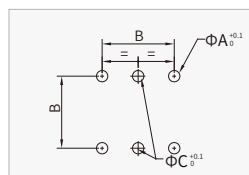

Series	Dimensions(mm)		
	ΦA	B	C
FAY	0.8	5.08	0.8

Push-Pull Connector

Designed for
Quick and Stable Installation





Push-Pull Connector

Designed for
Quick and Stable Installation





Push-Pull Connector

Designed for
Quick and Stable Installation



Global Sales & Marketing:

Headquartered in South of China, Finecables maintain contacts with customers throughout the world. Internationally, you can get in touch with Finecables by contacting our branches or regional distribution partners as below:



China

Headquarter (Factory)

Tel: +86-(0)769-8151 7898
 Fax: +86-(0)769-8504 5467
 Email: inof@finecables.com
 Address: No. 54 Changdi Road, Nanmian Community
 Humen Town Dongguan City, Guangdong Province



China

East China Sales Office

Tel: +86-136 2528 9019
 Email: smc.ec@finecables.com
 Address: No. 203, Building 20, Central
 Garden, Xinbei District, Changzhou City,
 China. 213001



China

Central China Sales Office

Tel: +86-(0)731-8433 3981
 Email: smc.cc@finecables.com
 Address: Shangcheng B3, Suite#1911, Kaiyuan
 Road 79, economic development zone, Changsha
 City, China.410100



China

Southwest China Sales Office

Tel: +86-186 2344 1625
 Email: fcsww@finecables.com
 Address: Room6, Floor2, Building 21, Chuangke
 Port Science and Technology Park, Shabin Road,
 Shapingba District, Chongqing Cit



China

East China Sales Office

Tel: +86-182 6006 0323
 Email: FCNJ@finecables.com
 Address: Room 1712, Building 1, Crystal Blue
 Bay, No. 1568 Shuanglong Avenue, Jiangning
 District, Nanjing City, Jiangsu Province



United States

Finecables Inc. (USA)

Tel: +1 206 420 3829 +1 206 457 5383
 Email: fc-usa@finecables.com
 Address: 1833 N 105th ST. STE# 306, Seattle,
 WA, 98133, USA



Japan

Sales Office (Japan)

Tel: 080-13904423
 Email: fc-jp@finecables.com
 Address: 3-3-19, Harumicho, Fuchu-shi,
 Tokyo, Japan. Post Code:183-0057



United Kingdom

Engineering & Business Development

Tel: +44 (0)7863761119
 Email: fc-uk@finecables.com
 Address: Sindens Nursery, Cross in Hand TN21
 OSH UK UK - United Kingdom



Germany

Engineering & Business Development

Tel: +49 (0)7531 8914 993
 Email: fc-de@finecables.com
 Address: Lohnerhofstrasse 2, 78467 Konstanz
 DE - Germany



Switzerland

Engineering & Business Development

Tel: +41 (0)71 669 17 85
 Email: fc-ch@finecables.com
 Address: Oberstrasse 4, 8274 Tägerwilen
 CH - Switzerland





www.finecables.com



FINECABLES ENTERPRISE CO., LIMITED

Address: No. 54 Changdi Road, Nanmian Community Humen Town
Dongguan City, Guangdong Province

Tel: +86-(0)769-8151 7898

Fax: +86-(0)769-8504 5467

Email: info@finecables.com

<http://www.finecables.com>

Copyright © Finecables Enterprise Co., Limited All rights reserved.

